



Addendum No. 1
Page 1 of 1

DATE: October 21, 2024

Joliet Junior College
1215 Houbolt Road
Joliet, IL 60431

TO: Prospective Bidders
SUBJECT: Addendum No. 1
PROJECT NAME: City Center Chiller Curb Repair
JJC PROJECT NO.: B25008

This Addendum forms a part of the Bidding and Contract Documents and modifies the original bidding document as posted on the JJC website. Acknowledge receipt of this addendum in the space provided on the Bid Form. FAILURE TO DO SO MAY SUBJECT BIDDER TO DISQUALIFICATION.

1. Please send cut sheet of the chillers so we have the weight and the proper isolators can be purchased.
 - a. ***See attached O&M Manual. It appears that the chillers have an operating weight of 23,044 lbs. based on cut sheet on page 164. The document also contains isolator information but it is unclear what which isolator was selected. We would assume that the contractor would be able to remove one of the isolators as they begin the work which may have markings on the actual isolator used.***

2. Is the roof under warranty?
 - a. ***Yes. The installed roof is a Firestone - Red Shield roofing system***

3. If so, please provide roofer information. If not, is there a preferred roofer?
 - a. ***Bennett & Brosseau Roofing installed the roof, but any roofing company that is certified with Firestone - Red Shield roofing system can be used.***

End of Addendum #1

Joliet Junior College
Construct City Center / Adult Education Facility
CDB Project #810-048-023
CDB Contract #16040343
ARCHITECT: Demonica Kemper Architects
HEATING
OPERATION & MAINTENANCE MANUAL
DODSON PLBG. HTG. & AIR COND., INC.
May 3, 2016

236430

AIR COOLED WATER CHILLERS

CHR-1,2,3,4 York Model #YVAA

EQUIPMENT SUBMITTAL FOR APPROVAL

**Joliet Junior College
City Center/Adult Education Facility
CDB #810-048-023**



EQUIPMENT:	Air Cooled Chillers
UNIT TAGS:	CHR-1 through CHR-4
QUANTITY:	4

PREPARED FOR:

Dodson Plumbing and Heating
823 N. Ladd Street
Pontiac, IL 61764
815-844-7131

PREPARED BY:

Steve Green
YORK/Johnson Controls
3007 Malmo Drive
Arlington Heights, IL 60005
847.364.1500 (p) / 847.364.1536 (f)

August 11, 2015
Revision #0

TABLE OF CONTENTS

- Submittal notes
- General description
- Bill of material
- Performance
- Drawings

SUBMITTAL NOTES

The following table must be completed prior to releasing the equipment for fabrication. Please initial the column indicating the information contained in this submittal has been verified, or indicate to refer to a marked-up page.

SUBMITTAL VERIFICATION	
	<i>Purchaser Initials</i>
Electrical voltage and electrical connections are compatible with jobsite requirements.	
Unit tag designations are correct	
Equipment dimensions and weights have been verified to comply with jobsite conditions and rigging requirements	

SUBMITTAL NOTES

Please fill out the following table and refer to the receiving/rigging instructions in this submittal to help ensure a smooth delivery and installation of the equipment.

DELIVERY INFORMATION	
	<i>Please fill out information below</i>
Contact name for coordinating delivery of equipment with transportation company	
Contact phone number	
Advance notice required from transportation company prior to delivering equipment (typically 48 hours)	
Ship to address:	
Other special shipping instructions or requirements	

GENERAL DESCRIPTION

1.01 GENERAL REQUIREMENTS

The requirements of this Section shall conform to the general provisions of the Contract, including General and Supplementary Conditions, Conditions of the Contract, and Contract Drawings.

1.02 SCOPE

Provide Microprocessor controlled, twin-screw compressor, air-cooled, liquid chillers of the scheduled capacities as shown and indicated on the Drawings, including but not limited to:

1. Chiller package
2. Charge of refrigerant and oil
3. Electrical power and control connections
4. Chilled fluid connections
5. Manufacturer start-up

1.03 QUALITY ASSURANCE

A. Products shall be Designed, Tested, Rated and Certified in accordance with, and Installed in compliance with applicable sections of the following Standards and Codes:

1. AHRI 550/590 – Water Chilling Packages Using the Vapor Compression Cycle
2. AHRI 370 – Sound Rating of Large Outdoor Refrigerating and Air-Conditioning Equipment
3. ANSI/ASHRAE 15 – Safety Code for Mechanical Refrigeration
4. ANSI/ASHRAE 34 – Number Designation and Safety Classification of Refrigerants
5. ASHRAE 90.1 – Energy Standard for Buildings Except Low-Rise Residential Buildings
6. ANSI/NFPA 70 – National Electrical Code (N.E.C.)
7. ASME Boiler and Pressure Vessel Code, Section VIII, Division 1
8. OSHA – Occupational Safety and Health Act
9. Manufactured in facility registered to ISO 9001
10. Conform to Intertek Testing Services for construction of chillers and provide ETL/cETL Listed Mark

B. Factory Run Test: Chiller shall be pressure-tested, evacuated and fully charged with refrigerant and oil, and shall be factory operational run tested with water flowing through the vessel.

C. Chiller manufacturer shall have a factory trained and supported service organization.

D. Warranty: Manufacturer shall Warrant all equipment and material of its manufacture against defects in workmanship and material for a period of eighteen (18) months from date of shipment or twelve (12) months from date of start-up, whichever occurs first.

Manufacturer shall Warrant the compressor against defects in workmanship and material for a period of (30) months from date of shipment or (24) months from date of start-up, whichever occurs first.

1.04 DELIVERY AND HANDLING

A. Unit shall be delivered to job site fully assembled with all interconnecting refrigerant piping and internal wiring ready for field installation and charged with refrigerant and oil by the Manufacturer.

B. Provide protective covering over vulnerable components for unit protection during shipment. Fit nozzles and open ends with plastic enclosures.

C. Unit shall be stored and handled per Manufacturer's instructions.

PART 2 - PRODUCTS

2.01 MANUFACTURERS

A. The design shown on the Drawings is based on YORK model YVAA chiller manufactured by Johnson Controls / YORK. Alternate equipment will be acceptable if the manufacturer's equipment meets the scheduled performance and complies with these specifications. If equipment manufactured by a manufacturer other than that scheduled is utilized, then the Mechanical Contractor shall be responsible for coordinating with the General Contractor and all affected Subcontractors to insure proper provisions for installation of the furnished unit. This coordination shall include, but not be limited to, the following:

1. Structural supports for units.
2. Piping size and connection/header locations.
3. Electrical power requirements and wire/conduit and overcurrent protection sizes.
4. Chiller physical size on plant layout.
5. Site noise considerations.

B. The Mechanical Contractor shall be responsible for all costs incurred by the General Contractor, Subcontractors, and Consultants to modify the building provisions to accept the furnished alternate equipment.

2.02 GENERAL

A. Description: Furnish, Install, and Commission factory assembled, charged, and operational run tested air-cooled screw compressor chiller as specified herein and shown on the Drawings. Chiller shall include, but is not limited to: a complete system with multiple independent refrigerant circuits, semi hermetic twin screw compressors, shell and tube hybrid falling film type evaporator, air-cooled condenser, R134a refrigerant, lubrication system, interconnecting wiring, safety and operating controls including capacity controller, control center, motor starting components, and special features as specified herein or required for safe, automatic operation.

B. Operating Characteristics:

1. Provide low and high ambient temperature control options as required to ensure unit is capable of operation from 0°F to 125°F (-18°C to 52°C) ambient temperature.
2. Provide capacity control system capable of reducing unit capacity to 10% of full load for 2 compressor units. Compressor shall start in unloaded condition. Application of factory installed hot gas bypass shall be acceptable as required to meet specified minimum load.

C. Cabinet: Unit panels, structural elements, control boxes and heavy gauge structural base shall be constructed of painted galvanized steel. All exposed sheet steel shall be coated with baked on powder paint to meet 500-hour salt spray test in accordance with the ASTM B117 standard.

D. Shipping: Unit shall ship in one piece and shall require installer to provide only a single evaporator inlet and outlet pipe connection. If providing chiller model that ships in multiple pieces, bid shall include all the material and field labor costs for factory authorized personnel to install a trim kit to connect the pieces as well as all interconnecting piping and wiring.

2.03 COMPRESSORS

- A. Compressors: Shall be direct drive, semi hermetic, rotary twin-screw type, including: muffler, temperature actuated 'off-cycle' heater, rain-tight terminal box, discharge shut-off service valve, suction shut-off service valve for each compressor, and precision machined cast iron housing. Design working pressure of entire compressor, suction to discharge, shall be 350 psig (24 barg) or higher. Compressor shall be U.L. Recognized.
- B. Compressor Motors: Refrigerant suction-gas cooled accessible hermetic compressor motor, full suction gas flow through 0.006" (0.1524 mm) maximum mesh screen, with inherent internal thermal overload protection and external current overload on all three phases.
- C. Balancing Requirements: All rotating parts shall be statically and dynamically balanced.
- D. Lubrication System: External oil separators with no moving parts, 450 psig (31 barg) design working pressure, and ETL listing shall be provided on the chiller. Refrigerant system differential pressure shall provide oil flow through service replaceable, 0.5 micron, full flow, cartridge type oil filter internal to compressor. Filter bypass, less restrictive media, or oil pump not acceptable.
- E. Capacity Control: Compressors shall start at minimum load. Provide Microprocessor control to command compressor capacity to balance compressor capacity with cooling load.

2.04 REFRIGERANT CIRCUIT COMPONENTS

- A. Refrigerant: R-134a. Classified as Safety Group A1 according to ASHRAE 34.
- B. Equipment supplied shall comply with LEED Energy & Atmosphere Credit 4, Enhanced Refrigerant Management.
- C. Each independent refrigerant circuit shall incorporate all components necessary for the designed operation including: liquid line shut-off valve with charging port, low side pressure relief device, removable core filter-drier and sight glass with moisture indicator.
- D. Chiller manufacturer shall provide an independent circuit for each compressor to provide maximum redundancy during chiller operation. If equipment does not have independent circuits per compressor, manufacturer shall provide owner one spare compressor of each unique size.
- E. Discharge lines shall be provided with manual compressor shut-off service valves.

2.05 HEAT EXCHANGERS

- A. Evaporator:
 - 1. Evaporator shall be shell and tube, hybrid falling film type with 3 pass arrangement to optimize efficiency and refrigerant charge. Tubes shall be high-efficiency, internally and externally enhanced type copper tubes with 0.035" (0.89 mm) minimum wall thickness at all intermediate tube supports to provide maximum tube wall thickness at the support area. Each tube shall be roller expanded into the tube sheets providing a leak proof seal, and be individually replaceable. Independent refrigerant circuits shall be provided per compressor.
 - 2. Constructed, tested, and stamped in accordance with applicable sections of ASME pressure vessel code for minimum 235 psig (16 barg) refrigerant side design working pressure and 150 psig (10 barg) liquid side design working pressure.
 - 3. Water boxes shall be removable to permit tube cleaning and replacement. Water boxes shall include liquid nozzle connections suitable for ANSI/AWWA C-606 couplings, welding, or flanges.
-

4. Provide vent and drain fittings, and thermo-statically controlled heaters to protect to -20°F (-28°C) ambient temperature in off-cycle. A separate power connection for evaporator heaters is required and shall be provided by the Contractor.
5. Connection location: Chilled liquid inlet and outlet nozzle connections are located at rear (opposite control panel) end of unit.

B. Air-cooled Condenser:

1. Condenser coils shall be microchannel type, parallel flow aluminum alloy tubes metallurgically brazed as one piece to enhanced aluminum alloy fins. Condenser coils shall be made of a single material to avoid galvanic corrosion due to dissimilar metals. Tube and fin type condenser coils are an acceptable alternate when tubes and fins are fabricated of the same metal material to avoid galvanic corrosion due to dissimilar metals. Unit shall include Louvered Panels (Condenser Coils): Painted steel to match unit panels, over external condenser coil faces.
2. Low Sound Fans with Variable Speed Drives. All fans shall be powered by VSDs. Fans shall provide vertical air discharge from extended orifices. Fans shall be composed of corrosion resistant aluminum hub and glass-fiber-reinforced polypropylene composite blades molded into a low-noise airfoil section. Fan impeller shall be dynamically balanced for vibration-free operation. Fan guards of heavy gauge, PVC (polyvinyl chloride) coated or galvanized steel.
3. Fan Motors: High efficiency, direct drive, 3-phase, insulation class “F”, current protected, Totally Enclosed Air-Over (TEAO), with double sealed, permanently-lubricated ball bearings. Open Drip Proof (ODP) fan motors will not be acceptable.

2.06 INSULATION

- A. Material: Closed-cell, flexible, UV protected, thermal insulation complying with ASTM C 534 Type 2 (Sheet) for preformed flexible elastomeric cellular thermal insulation in sheet and tubular form.

B. Thickness: 3/4" (19mm.)

- C. Thermal conductivity: 0.26 (BTU/HR-Ft²-°F/in) maximum at 75°F mean temperature.

- D. Factory-applied insulation over cold surfaces of liquid chiller components including evaporator shell, water boxes, and suction line. Liquid nozzles shall be insulated by Contractor after pipe installation.

- E. Adhesive: As recommended by insulation manufacturer and applied to 100 percent of insulation contact surface including all seams and joints.

2.07 ACOUSTICAL DATA

- A. Provide acoustical sound power or sound pressure level data in decibels (dB) at the scheduled eight (8) octave band center frequencies. A-weighted sound data alone is not acceptable.

- B. Provide all sound power or sound pressure level data at 100%, 75%, 50%, and 25% load.

- C. Supplied equipment shall not exceed scheduled sound power or sound pressure level data at any load point. The mechanical Contractor shall be responsible for any additional costs associated with equipment deviation.

- D. Acoustical performance ratings shall be in accordance with AHRI Standard 370.
-

2.08 POWER AND ELECTRICAL REQUIREMENTS

A. Power/Control Panel:

1. Factory installed and wired NEMA 3R, powder painted steel cabinets with tool lockable, hinged, latched, and gasket sealed outer doors equipped with wind struts for safer servicing. Provide main power connection(s), compressor starters and fan motor contactors, current overloads, and factory wiring.
2. Panel shall include control display access door.

B. Single Point Power:

1. Provide single point power connection to chiller, shall be 3 phase of scheduled voltage.
2. Amps.) Rating shall be published in accordance with UL508.

E. Motor Starters: Motor starters shall be zero electrical inrush current (Variable Frequency Drives) or reduced inrush type (Closed transition Wye-Delta or Solid State) for minimum electrical inrush. Open transition Wye-Delta and Across the Line type starters will not be acceptable.

F. Power Factor:

1. Provide equipment with power factor correction capacitors as required to maintain a displacement power factor of 95% at all load conditions.
2. The installing contractor is responsible for additional cost to furnish and install power factor correction capacitors if they are not factory mounted and wired.

G. All exposed power wiring shall be routed through liquid-tight, UV-stabilized, non-metallic conduit.

H. Supplied equipment shall not exceed scheduled Minimum Circuit Ampacity (MCA). The mechanical Contractor shall be responsible for any additional costs associated with equipment deviation.

2.09 CONTROLS

A. General:

1. Provide automatic control of chiller operation including compressor start/stop and load/unload, anti-recycle timers, condenser fans, evaporator pump, evaporator heater, unit alarm contacts and run signal contacts.
 2. Chiller shall automatically reset to normal chiller operation after power failure.
 3. Unit operating software shall be stored in non-volatile memory. Field programmed set points shall be retained in lithium battery backed regulated time clock (RTC) memory for minimum 5 years.
-

4. Alarm contacts shall be provided to remote alert for any unit or system safety fault.

B. Display and Keypad:

1. Provide minimum 80 character liquid crystal display that is both viewable in direct sunlight and has LED backlighting for nighttime viewing. Provide one keypad and display panel per chiller.
2. Display and keypad shall be accessible through display access door without opening main control/electrical cabinet doors.
3. Display shall provide a minimum of unit setpoints, status, electrical data, temperature data, pressures, safety lockouts and diagnostics without the use of a coded display.
4. Descriptions in English (or available language options), numeric data in English (or Metric) units.
5. Sealed keypad shall include unit On/Off switch.

C. Programmable Setpoints (within Manufacturer limits): Display language, chilled liquid cooling mode, local/remote control mode, display units mode, system lead/lag control mode, remote temperature reset, remote current limit, remote sound limit, low ambient temperature cutout enable/disable, leaving chilled liquid setpoint and range, maximum remote temperature reset.

D. Display Data: Chilled liquid leaving and entering temperatures; outside ambient air temperature; lead system; evaporator pump status; active remote control; compressor suction, discharge, and oil pressures per refrigerant circuit; compressor discharge, motor, and oil temperatures per refrigerant circuit; saturation temperatures per refrigerant circuit; compressor speed; condenser fan status; condenser subcooling temperature; condenser drain valve percentage open; compressor capacity in percentage of Full Load Amps; compressor number of starts; run time; operating hours; evaporator heater status; history data for last ten shutdown faults; history data for last 20 normal (non-fault) shutdowns.

E. Predictive Control Points: Unit controls shall avoid safety shutdown when operating outside design conditions by optimizing the chiller controls and cooling load output to stay online and avoid safety limits being reached. The system shall monitor the following parameters and maintain the maximum cooling output possible without shutdown of the equipment: motor current, suction pressure, discharge pressure, starter internal ambient temperature, and starter baseplate temperature.

F. System Safeties: Shall cause individual compressor systems to perform auto-reset shut down if: high discharge pressure or temperature, low suction pressure, low motor current, high/low differential oil pressure, low discharge superheat, high motor temperature, system control voltage.

G. Unit Safeties: Shall be automatic reset and cause compressors to shut down if: high or low ambient temperature, low leaving chilled liquid temperature, under voltage, flow

switch operation. Contractor shall provide flow switch and wiring per chiller manufacturer requirements.

H. Manufacturer shall provide any controls not listed above, necessary for automatic chiller operation. Mechanical Contractor shall provide field control wiring necessary to interface sensors to the chiller control system.

2.10 ACCESSORIES AND OPTIONS

Some accessories and options supersede standard product features. All options are factory-mounted unless otherwise noted.

A. CONTROLS OPTIONS:

1. Gateway: Provides communication for Building Automation Systems, including BACnet (MS/TP), Modbus, N2, and LON. (Field Commissioned by BAS Manufacturer)

B. GENERAL OPTIONS:

1. Differential Pressure Switch: 3-45 psig (0.2-3 barg) range with 1/4" NPTE pressure connections. (Field Mounted by Contractor)
2. Vibration Isolation (All Options Field Mounted by Contractor):
Provide 1" Deflection Spring Isolators: Level adjustable, spring and cage type isolators for mounting under the unit base rails

PART 3 - EXECUTION

3.01 INSTALLATION

A. General: Rig and Install in full accordance with Manufacturer's requirements, Project drawings, and Contract documents.

B. Location: Locate chiller as indicated on drawings, including cleaning and service maintenance clearance per Manufacturer instructions. Adjust and level chiller on support structure.

C. Components: Installing Contractor shall provide and install all auxiliary devices and accessories for fully operational chiller.

D. Electrical: Coordinate electrical requirements and connections for all power feeds with Electrical Contractor.

E. Controls: Coordinate all control requirements and connections with Controls Contractor.

F. Finish: Installing Contractor shall paint damaged and abraded factory finish with touch-up paint matching factory finish.

BILL OF MATERIAL

TAGS	QTY	DESCRIPTION	YORK MODEL #
CHR-1, CHR-2, CHR-3, CHR-4	4	Air Cooled Chillers	YVAA

Terms: F.O.B. Factory, Freight Allowed and Prepaid, Net 30 Days, No Taxes Included

Items Included by JCI

Four York Air Cooled Chillers

- Variable Speed Screw Compressor
 - ✓ 460 volts, 3 phase, 60 Hz
- Service Isolation Valves
- Louvered paneled condenser section
- 1" Isolation Springs – installed by others.
- Single point power disconnect switches on each circuit
- BACnet interface
- Chiller Startup
- 12 month parts and labor warranty
- Two year compressor parts and labor warranty
- Water box heater for freeze protection down to -20F – separate 120V power by others.
- Acoustical package to meet scheduled sound.

Items Not Included:

- Rigging, hauling, or providing access for equipment.
 - Piping and Wiring
 - Factory performance test.
 - Field painting is not included - factory enamel coat is provided
-

PERFORMANCE INFORMATION

Unit Tag	Qty	Model No.	Capacity (Tons)	Volts/Ph/Hz	Refrigerant
CHR-1, CHR-2, CHR-3, CHR-4	4	YVAA0413HYV46	367.0	460/3/60	R134a

Pin:

BASE MODEL	POWER	CONTROLS	PIPING	COMP	EVAPORATOR	COND	CABINET	MISC	WARR			
YVAA0413HYV46BA	VOXX	XEAXLXXXX60	42XOSXX	V198W	1SXDA3B	MXV	5X1XX	XXXX	FXSX			
5	10	15	20	25	30	35	40	45	50	55	60	65

Evaporator Data		Evaporator Data (Cont.)		Performance Data	
EWT (°F)	54.0	Min. Flow Rate (gpm)	350.0	EER / COP	9.7 / 2.9
LWT (°F)	42.0	Max. Flow Rate (gpm)	1200.0	NPLV	16.7 / 4.9
Design Flow Rate (gpm)	803.7			Minimum Unit Capacity	10 %
Pressure Drop (ft.)	35.7	Condenser Data		Physical Data	
Fluid	P.G. 40.0%	Ambient Temp. Design (°F)	95.0	Rigging Wt. (lbs.)	22237
Fouling Factor	0.00010	Altitude (ft.)	0	Operating Wt. (lbs.)	23044
Water Volume (gal)	130.0	Ambient Temp. Min (°F)	0.0		

Electrical Data				
Circuit	1	2	3	4
Compressor RLA	344	239		
Fan QTY/FLA (each)	12/2.4	8/2.4		

Single Point				
Min. Circuit Ampacity	723			
Recommended Fuse/CB Rating	1000			
Max. Inverse Time CB Rating	1000			
Max. Dual Element Fuse Size (Amps)	1000			
Unit Short Circuit Withstand (STD)	50 kA			
Wire Lugs Per Phase*	4			
Wire Range (Lug Size)	#1/0 - 750 KCM			
Unit Power Factor	0.95			
Control KVA	3.0			
Starter Type	VSD			
			Operating Condition Electrical Data	
			Compressor kW	420.6
			Total Fan kW	31.8
			Total kW	452.4
			Total Current at Rated Conditions	N/A



Notes: Evaporator contains a glycol or other secondary coolants for freeze protection with a leaving chilled fluid temperature above 32°F and is certified in accordance with the AHRI Air-Cooled Water Chilling Packages Using Vapor Compression Cycle Certification, Auxiliary components included in total KW - Oil heaters, Chiller controls. Auxiliary power is already included in the compressor and fan power

Notes:

* Use Copper Conductors only

Part Load Rating Data				
Load %	Ambient (°F)	Capacity (Tons)	Compressor kW	Unit Efficiency
100.0	95.0	367.0	420.6	9.7 / 2.9
75.0	80.0	275.2	229.3	12.9 / 3.8
50.0	65.0	183.5	104.4	18.7 / 5.5
25.0	55.0	91.7	42.2	22.8 / 6.7

SOUND POWER LEVELS (In Accordance with AHRI 370) – Octave Band Center Frequency, Hz YVAA0413HYV46 (Equipped with Low Sound Fans with Variable Speed Control)										
Load %	Ambient (°F)	63	125	250	500	1K	2K	4K	8K	LWA
100.0	95.0	99.0	100.0	100.0	106.0	100.0	97.0	93.0	87.0	106.0
75.0	80.0	98.0	98.0	99.0	99.0	96.0	90.0	87.0	83.0	100.0
50.0	65.0	94.0	93.0	95.0	95.0	93.0	85.0	84.0	81.0	97.0
25.0	55.0	89.0	88.0	89.0	96.0	87.0	80.0	80.0	80.0	94.0

SOUND PRESSURE LEVELS in dB at 30.0 (ft.) ** YVAA0413HYV46 (Equipped with Low Sound Fans with Variable Speed Control)										
Load %	Ambient (°F)	63	125	250	500	1K	2K	4K	8K	dB(A)
100.0	95.0	72.0	72.0	73.0	79.0	73.0	69.0	66.0	60.0	79.0
75.0	80.0	70.0	70.0	71.0	72.0	69.0	63.0	60.0	56.0	73.0
50.0	65.0	67.0	66.0	67.0	68.0	66.0	58.0	57.0	53.0	70.0
25.0	55.0	62.0	61.0	62.0	68.0	60.0	53.0	52.0	53.0	67.0

** Chiller is assumed to be a point source on a reflecting (hemispherical radiation)

YVAA0413HYV46 Performance at AHRI Conditions					
Evaporator Data		Condenser Data		Performance Data	
EWT (°F)	54.0	Ambient Temp. (°F)	95.0	EER / COP	10.3 / 3.0
LWT (°F)	44.0	Altitude (ft.)	0	EER IPLV/COP IPLV	18.1 / 5.3
Flow Rate (gpm)	966.9			Capacity (Tons)	402.9
Pressure Drop (ft.)	47.6				
Fluid	Water				
Fouling Factor	0.00010				
Water Volume (gal)	130.0				

DRAWINGS

The following drawings are contained in this section:

- Product drawing

- NOTES:
1. PLACEMENT ON A LEVEL SURFACE FREE OF OBSTRUCTIONS (INCLUDING SMOKE RISERS) FOR INTER OPERATION OR AIR FLOW. CLEARANCES TO THE UNIT SHALL BE AS SPECIFIED FOR OPERATION AND EASE OF MAINTENANCE. SITE RESTRICTIONS MAY COMPROMISE MINIMUM CLEARANCES INDICATED BELOW. RESULTING IN UNPREDICTABLE AIR FLOW PATTERNS AND POSSIBLE DIMINISHED PERFORMANCE. YORK'S UNIT CONTROLS WILL OPTIMIZE OPERATION WITHOUT NUISANCE HIGH PRESSURE SAFETY CUTOUT; HOWEVER, THE SYSTEM DESIGNER MUST CONSIDER POTENTIAL PERFORMANCE DEGRADATION. ACCESS TO THE UNIT CONTROL PANEL SHALL BE MAINTAINED AT ALL TIMES. THE UNIT SHALL BE INSTALLED ON A LEVEL SURFACE. THE UNIT SHALL BE INSTALLED ON ISOLATORS RECOMMENDED MINIMUM CLEARANCES: SIDE TO WALL 6" REAR TO WALL 6"; CONTROL PANEL TO WALL - 4"; TOP - NO OBSTRUCTIONS ALLOWED; DISTANCE BETWEEN ADJACENT UNITS - 10" NO MORE THEN ONE ADJACENT WALL MAY BE HIGHER THEN THE UNIT.
 2. WEIGHTS (LB): SHIPPING - 22,227; OPERATING - 23,044.
 3. CENTER OF GRAVITY FROM ORIGIN: X= 200.00; Y= 46.00; Z= 100.00.
 4. CONNECTION TO WALL SHALL BE APPROXIMATELY 6".
 5. 1" NOMINAL DEFLECTION SPRING ISOLATORS (NOT SHOWN) WILL INCREASE OVERALL UNIT HEIGHT BY APPROXIMATELY 6".

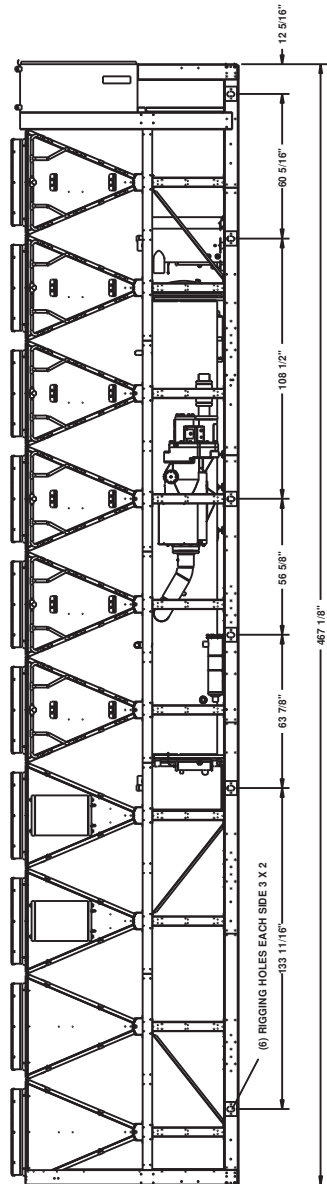
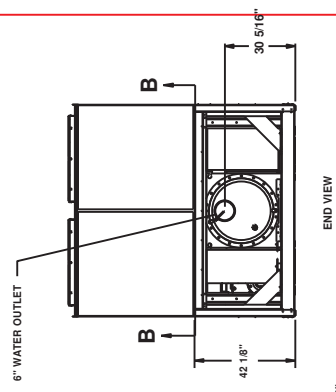
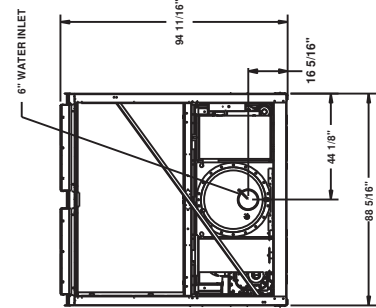
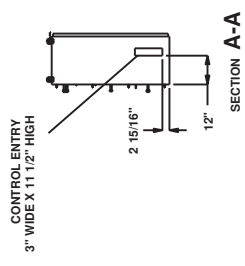
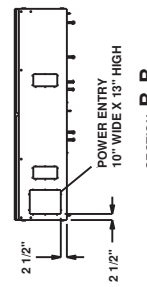
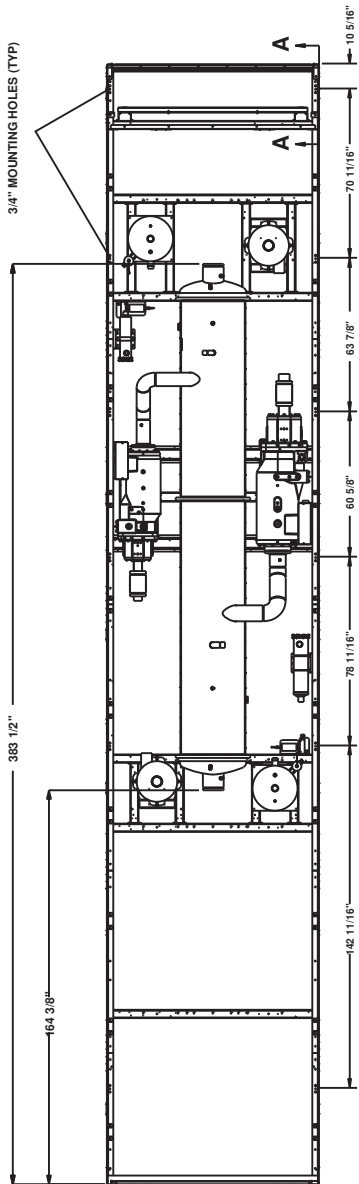

PRODUCT DRAWING
 AIR-COOLED SCREW CHILLER
 MODEL: YVAA0413HYV/46
 NOT FOR CONSTRUCTION

Project Name : JJC City Center
 Engineer : KJWW - Naperville
 Contractor : Dodson Heating and Plumbing

York Contract# : 5N020130
 CH-1, CH-2, CH-3, CH-4

Date : 07/31/2015 7:32:48
 Rev. Date :
 Form : 201.28-EG1
 Dwg. Lev. : 01/11
 Dwg. Scale : NTS



CDI EXISTING CURB VERIFICATION

PLEASE DO NOT USE RTU DIMENSIONS

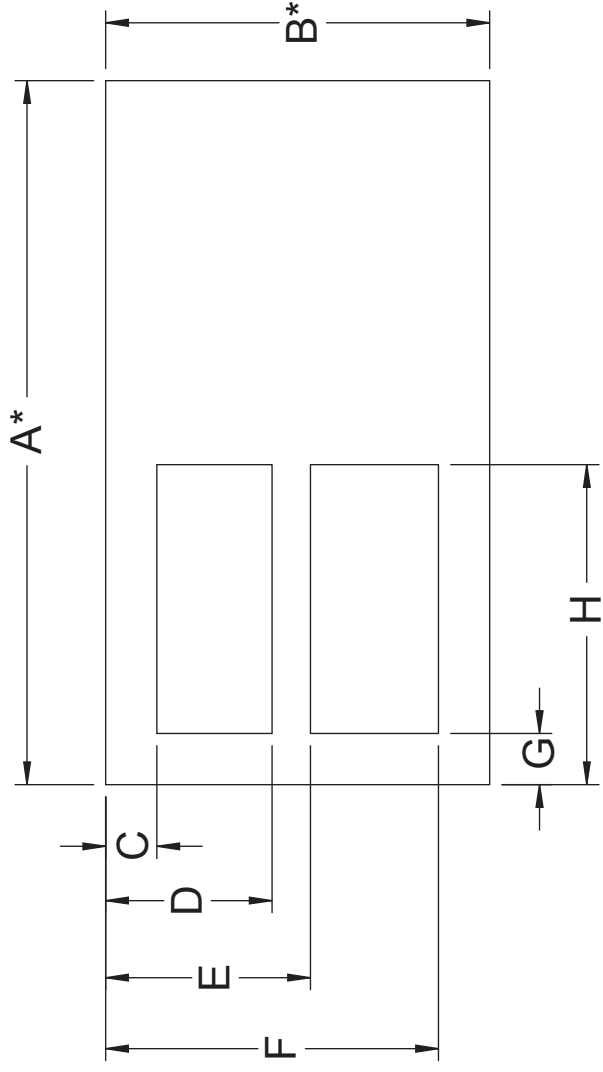

***CDI WILL BE ADDING 1-1/2" (1.5") OVERSIZE TO THE CURB OD'S (A & B). PLEASE PROVIDE ONLY ACTUAL CURB DIMENSIONS (DO NOT ADD OVERSIZE)**

EXISTING UNIT BRAND _____

MODEL _____

A*	B*	C	D
E	F	G	H

PLEASE FILL IN CURB DIMENSIONS "A" THROUGH "H" AND NOTE RETURN AND SUPPLY, FEEL FREE TO CALL(1-888-234-7001) WITH ANY QUESTIONS

Please also note the following information

- Note any obstructions near the existing curb (EX. Wall, Other units, Hoods, etc)
- Note any height restrictions.
- Note existing curb height.

EXISTING UNIT BRAND _____

MODEL _____

***CDI WILL BE ADDING 1-1/2" (1.5") OVERSIZE TO THE CURB OD'S (J & K). PLEASE PROVIDE ONLY ACTUAL CURB DIMENSIONS (DO NOT ADD OVERSIZE)**

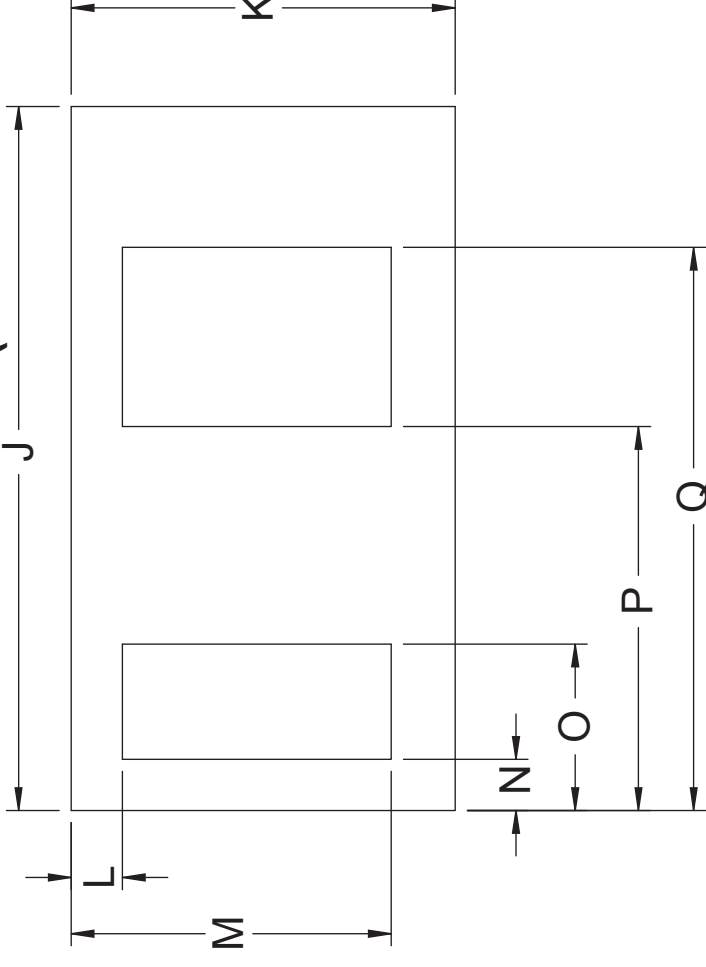

REVISIONS			
REV	DESCRIPTION	DATE	APPROVED
01	INITIAL DRAWING	11/18/2004	TC
02	UPDATED ADDRESS	6/18/2007	TC
03	ADDED OVERSIZE NOTE	6/5/12	MWG
04	ADD BRAND AND MODEL NOTE	4/21/2014	HMH

J*	K*	L	M
N	O	P	Q

APPROVALS	DATE	TITLE
DRAWN: hhorn	4/21/2014	CDI EXISTING CURB VERIFICATION
CHECKED:		
FILE NAME:	9999 REV4	DRAWING NO.:
17560 TYLER ST NW	9999 REV4	REV: 04
ELK RIVER, MN 55330	ECO #:	SCALE: 1:15 SHEET: 1 OF 1
(763)391-7790		
(763)391-7851		

DIMENSIONS ARE IN INCHES UNLESS NOTED OTHERWISE (25.40 mm)

OPTIONS:

MATERIAL: 12ga. GAL STEEL
 1X4 WOOD NAILER
 NO FLOOR
 DIVIDER WALL(S)
 3/8" HARDWARE INCLUDED

DIMENSIONED AND TOLERENCED PER ANSI Y14.5M-1982

REVISIONS

REV.	ECO#	DESCRIPTION	DATE	APPROVED
1		INITIAL DWG	8/14/2015	DES

Attn: _____
 Tag: _____
 Approval: _____

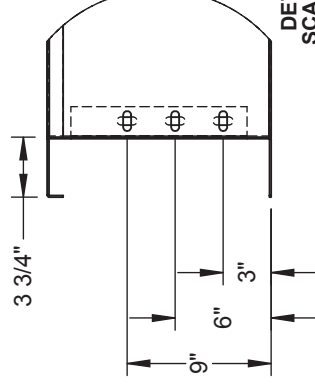
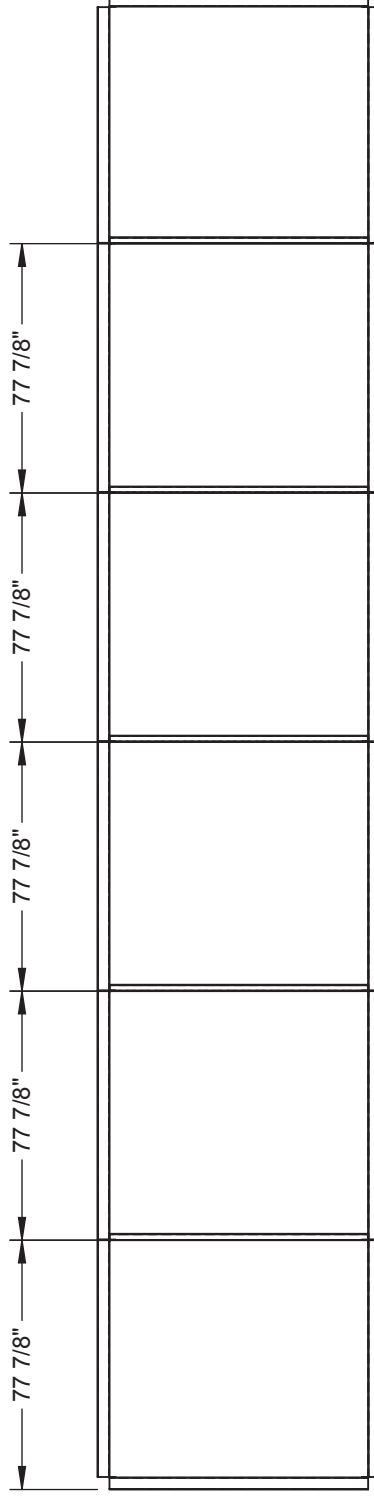
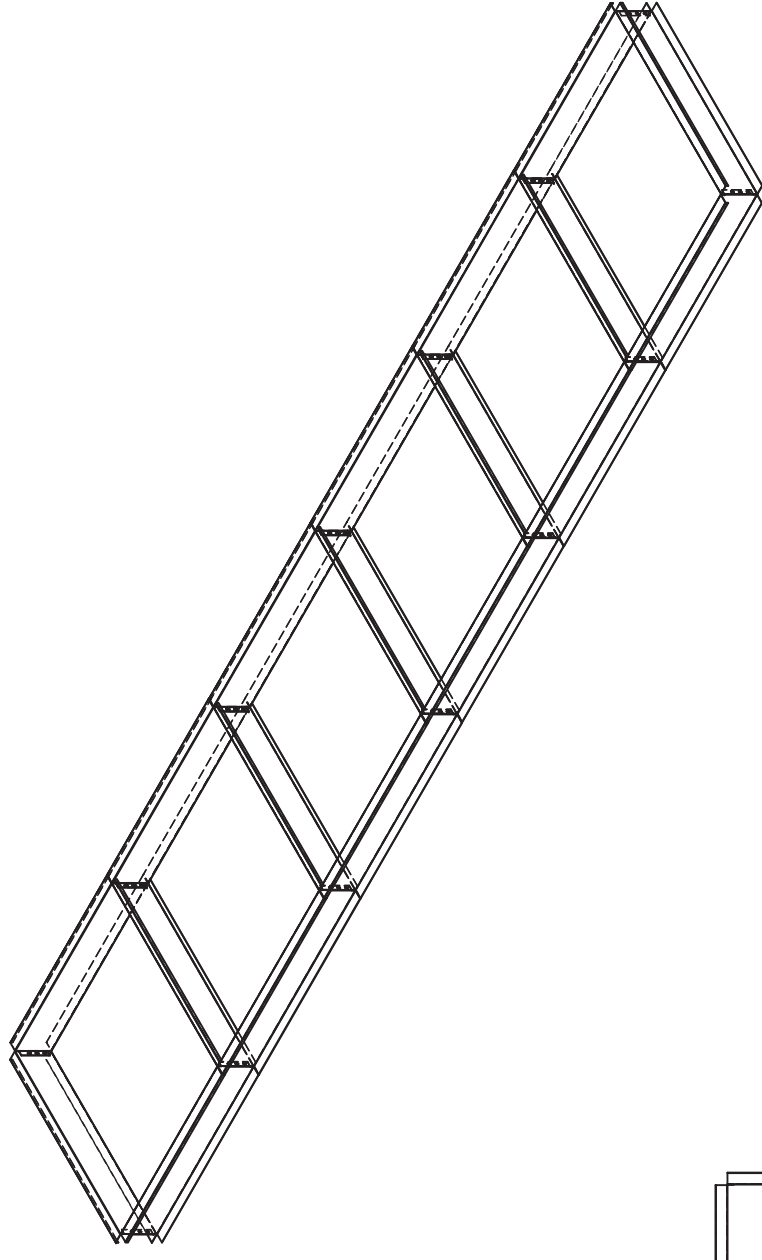

DETAIL C
 SCALE 1 : 12

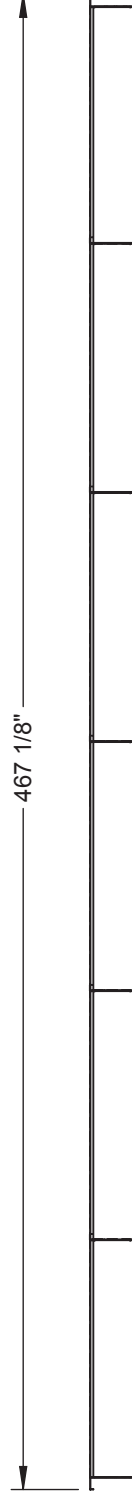

APPROVALS DRAWN: dsamuelsion CHECKED: _____ DIMENSIONS ARE AS FOLLOWS: 1.00 in [25.40 mm]		DATE 8/14/2015	TITLE/FILE NAME: 663676-2-0(K)014-9999
*VERIFY EXISTING CURB OD *VERIFY SUPPLY AND RETURN OPENINGS *NOTE ANY CHANGES *CALL WITH ANY QUESTIONS *FAX BACK IF DRAWING IS OK AS IS		APPROXIMATE CURB WEIGHT (LBS.) ECO #: 17560 TYLER ST NW ELK RIVER, MN 55330 (763)391-7790 (763)391-7851	APPROVED DES
3RD ANGLE PROJECTION		SCALE: 1:60	SHEET: 1 OF 3

- NOTES:**
1. PLACEMENT ON A LEVEL SURFACE FREE OF OBSTRUCTIONS (INCLUDING SNOW, FOR WINTER OPERATION) OR AIR RECIRCULATION ENSURES RATED PERFORMANCE, RELIABLE OPERATION AND EASE OF MAINTENANCE. SITE RESTRICTIONS MUST BE CONSIDERED. UNDESIRABLE BELIEF CONDITIONS RESULTING IN UNPREDICTABLE AIR FLOW PATTERNS WILL DIMINISH PERFORMANCE. YORK'S UNIT CONTROLS WILL OPTIMIZE OPERATION WITHOUT NUISANCE HIGH PRESSURE SAFETY CUTOUT; HOWEVER, THE SYSTEM DESIGNER MUST CONSIDER POTENTIAL PERFORMANCE DEGRADATION, ACCESS TO THE UNIT CONTROL CENTER ASSUMES THE UNIT IS NO HIGHER THEN ON SPRING ISOLATORS RECOMMENDED MINIMUM CLEARANCES: SIDE TO WALL: 6" REAR TO WALL: 6"; CONTROL PANEL TO WALL: 4"; FRONT TO WALL: 12" CLEARANCE BETWEEN ADJACENT UNITS: 10" NO MORE THEN ONE ADJACENT WALL MAY BE HIGHER THEN THE UNIT.
 2. WEIGHTS (LBS): SHIPPING - 22,237, OPERATING - 23,044.
 3. CENTER OF GRAVITY FROM ORIGIN: X= 200.8", Y= 46.2".
 4. WATER CONNECTIONS ARE GROOVED FOR VICTALIC CONNECTION
 5. 1" NOMINAL DEFLECTION SPRING ISOLATORS (NOT SHOWN) WILL INCREASE OVERALL UNIT HEIGHT BY APPROXIMATELY 6".

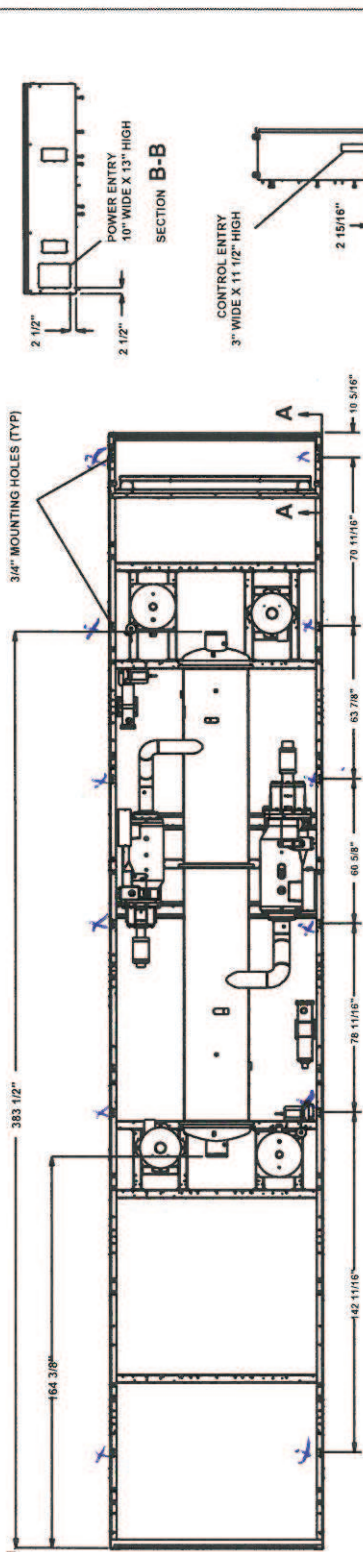

Isolator Mounting Locations (inches)

	1	2	3	4	5	6	7	8	9	10
L	(10.2,86.8)	(80.5,86.8)	(144.8,86.8)	(205.3,86.8)	(284.1,86.8)	(426.8,86.8)				
R	(10.2,1.3)	(80.5,1.3)	(144.8,1.3)	(205.3,1.3)	(284.1,1.3)	(426.8,1.3)				

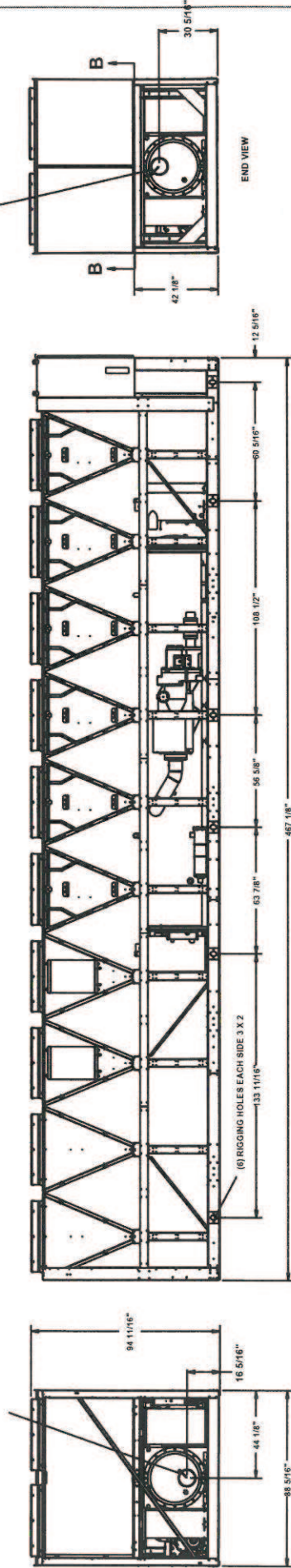

Isolator Weights (lbs) (if selected)

	1	2	3	4	5	6	7	8	9	10
L	835	1298	3072	3072	2765	1065				
R	818	1458	2477	2477	2642	1065				

PRODUCT DRAWING
 AIR-COOLED SCREW CHILLER
 MODEL: YVAA0413HYV46
 NOT FOR CONSTRUCTION

YORK
 A JOHNSON CONTROLS COMPANY

Project Name : WF-JJC City Center
 Location :
 Engineer :
 Contractor :
 For :

Sold To :
 Cust Purch Order# :
 York Contract# : 5N020130
 UNIT TAG:

Date : 7/31/2015 7:32:48
 Rev. Date :
 Form : 201.28-EG1
 Dwg. Lev. : 01/11
 Dwg. Scale : NTS

RECEIVING/RIGGING INSTRUCTIONS

The installing contractor is responsible to provide York with a contact to coordinate the delivery of the equipment in this submittal. Please fill out the information requested in the Submittal Notes section in the front of this submittal.

It is the installing contractor's responsibility to verify the following prior to signing the bill of lading presented by the transportation company:

- Ensure everything on the bill of lading was delivered
- Visually perform a thorough inspection of all equipment for any signs of shipping damage

Any short-shipments or shipping damage must be noted on the bill of lading prior to signing. The transportation company will provide you with instructions for filing a claim. It is the installing contractor's responsibility to work directly with the transportation company to resolve any shipping claims.



AIR-COOLED SCREW LIQUID CHILLERS

INSTALLATION, OPERATION, MAINTENANCE

Supersedes: 201.28-NM1.1 (514)

Form 201.28-NM1.1 (215)

035-23219-100

MODEL YVAA STYLE A AIR-COOLED SCREW LIQUID CHILLERS WITH VARIABLE SPEED DRIVE FRAME SIZES 015 - 052

**150 - 500 TONS
525 - 1750 KW
2 COMPRESSOR
50 AND 60 HZ**



LD15045

HFC-134A

Issue Date:
February 6, 2015



IMPORTANT!

READ BEFORE PROCEEDING!

GENERAL SAFETY GUIDELINES

This equipment is a relatively complicated apparatus. During rigging, installation, operation, maintenance, or service, individuals may be exposed to certain components or conditions including, but not limited to: heavy objects, refrigerants, materials under pressure, rotating components, and both high and low voltage. Each of these items has the potential, if misused or handled improperly, to cause bodily injury or death. It is the obligation and responsibility of rigging, installation, and operating/service personnel to identify and recognize these inherent hazards, protect themselves, and proceed safely in completing their tasks. Failure to comply with any of these requirements could result in serious damage to the equipment and the property in

which it is situated, as well as severe personal injury or death to themselves and people at the site.

This document is intended for use by owner-authorized rigging, installation, and operating/service personnel. It is expected that these individuals possess independent training that will enable them to perform their assigned tasks properly and safely. It is essential that, prior to performing any task on this equipment, this individual shall have read and understood the on-product labels, this document and any referenced materials. This individual shall also be familiar with and comply with all applicable industry and governmental standards and regulations pertaining to the task in question.

SAFETY SYMBOLS

The following symbols are used in this document to alert the reader to specific situations:



Indicates a possible hazardous situation which will result in death or serious injury if proper care is not taken.



Identifies a hazard which could lead to damage to the machine, damage to other equipment and/or environmental pollution if proper care is not taken or instructions are not followed.



Indicates a potentially hazardous situation which will result in possible injuries or damage to equipment if proper care is not taken.

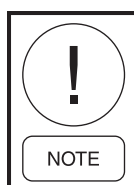

Highlights additional information useful to the technician in completing the work being performed properly.



External wiring, unless specified as an optional connection in the manufacturer's product line, is not to be connected inside the control cabinet. Devices such as relays, switches, transducers and controls and any external wiring must not be installed inside the micro panel. All wiring must be in accordance with Johnson Controls' published specifications and must be performed only by a qualified electrician. Johnson Controls will NOT be responsible for damage/problems resulting from improper connections to the controls or application of improper control signals. Failure to follow this warning will void the manufacturer's warranty and cause serious damage to property or personal injury.

CHANGEABILITY OF THIS DOCUMENT

In complying with Johnson Controls' policy for continuous product improvement, the information contained in this document is subject to change without notice. Johnson Controls makes no commitment to update or provide current information automatically to the manual or product owner. Updated manuals, if applicable, can be obtained by contacting the nearest Johnson Controls Service office or accessing the Johnson Controls QuickLIT website at <http://cgproducts.johnsoncontrols.com>.

It is the responsibility of rigging, lifting, and operating/service personnel to verify the applicability of these documents to the equipment. If there is any question

regarding the applicability of these documents, rigging, lifting, and operating/service personnel should verify whether the equipment has been modified and if current literature is available from the owner of the equipment prior to performing any work on the chiller.

CHANGE BARS

Revisions made to this document are indicated with a line along the left or right hand column in the area the revision was made. These revisions are to technical information and any other changes in spelling, grammar or formatting are not included.



The Control/VSD Cabinet contains lethal high AC and DC voltages. Before performing service inside the cabinet, remove the AC supply feeding the chiller and verify using a non-contact voltage sensor.



The DC voltage on the VSD DC Bus will take 5 minutes to bleed off, after AC power is removed. Always check the DC Bus Voltage with a Voltmeter to assure the capacitor charge has bled off before working on the system.



NEVER short out the DC Bus to discharge the filter capacitors.



NEVER place loose tools, debris, or any objects inside the Control Panel/VSD Cabinet.



NEVER allow the Control Panel VSD Cabinet doors to remain open if there is a potential for rain to enter the panel. Keep doors closed and assure all latches are engaged on each door unless the unit is being serviced.



ALWAYS lockout the disconnect supplying AC to the chiller.



The 1L Line Inductor will reach operating temperatures of over 150°C (300°F) DO NOT open panel doors during operation. Assure the inductor is cool whenever working near the inductor with power OFF.

ASSOCIATED LITERATURE

MANUAL DESCRIPTION	FORM NUMBER
Equipment Pre-Startup and Startup Checklist	201.28-CL2
YVAA Style A Frame Size 015 - 027, 2 Compressor 60 Hz (150-350 Tons) YVAA Style A Frame Size 054 - 098, 2 Compressor 50 Hz (525-950 KW) Manufactured before April 2012	201.28-RP1
YVAA Style A Frame Size 015 - 052, 2 Compressor 50 & 60 Hz (150-500 Tons) (Manufactured after April 2012 to before September 2014)	201.28-RP2
YVAA Style B Frame Size 015 - 052, 2 Compressor 50 & 60 Hz (150-500 Tons) (Manufactured after September 2014)	201.28-RP3

THIS PAGE INTENTIONALLY LEFT BLANK

TABLE OF CONTENTS

SECTION 1 - GENERAL CHILLER INFORMATION AND SAFETY	13
Introduction.....	13
Warranty.....	13
Quality Assurance and Safety	13
Fluorinated Greenhouse Gases	14
Responsibility for Safety.....	14
About This Manual.....	14
Misuse of Equipment.....	14
Suitability for Application	14
Structural Support	14
Mechanical Strength	14
General Access	14
Pressure Systems	15
Electrical.....	15
Rotating Parts.....	15
Sharp Edges.....	15
Refrigerants and Oils.....	15
High Temperature and Pressure Cleaning	15
Emergency Shutdown	16
Safety Labels.....	16
SECTION 2 - PRODUCT DESCRIPTION	17
General System Description.....	17
Semi-Hermetic YORK Twin-Screw Compressors.....	18
Evaporator.....	19
Condenser.....	19
Refrigerant Circuit	19
Electrical.....	19
Building Automation System Capabilities	19
Microcomputer Control Center	20
Display Data.....	20
Programmable Setpoints	20
Accessories and Options.....	21
Sound Attenuation	21
Fan Options.....	21
Condenser Coils.....	21
Condenser Coil Protection	21
Protective Chiller Panels	21
Evaporator Options	22
Controls Options.....	22
General Options	22
Vibration Isolation.....	23

TABLE OF CONTENTS (CONT'D)

SECTION 3 - RIGGING, HANDLING AND STORAGE	25
Lifting Weights	25
Delivery and Storage	25
Inspection	25
Moving the Chiller.....	26
Unit Removal From Shipping Container	26
Lifting Using Lugs.....	26
Lifting Using Shackles	26
 SECTION 4 - INSTALLATION	 37
Location Requirements	37
Outdoor Installations	37
Location Clearances.....	37
Recommended Minimum Clearances	37
Vibration Isolators.....	38
Installation	38
Shipping Braces	38
Chilled Liquid Piping.....	39
General Requirements	39
Water Treatment.....	40
Pipework Arrangement	40
Minimum Water Volume	40
Leaving Water Temperature Out of Range.....	40
Flow Rate Out of Range.....	40
Thermal Storage.....	41
Variable Primary Flow	41
Connection Types and Sizes.....	41
Evaporator Connections.....	41
Option Flanges	43
Refrigerant Relief Valve Piping.....	43
Electrical Connection.....	43
Power Wiring	44
Power Supply Wiring	44
115VAC Control Supply Transformer.....	44
Control Wiring.....	44
Volts Free Contacts	44
Chilled Liquid Pump Starter.....	44
Run Contact	44
Alarm Contacts.....	44
System Inputs.....	45
Flow Switch	45
Remote Run / Stop.....	45
Remote Print	45
Optional Remote Setpoint Offset – Temperature.....	45
Optional Remote Setpoint Offset – Current.....	45
Optional Remote Setpoint Offset – Sound Limiting.....	45
Power Supply Wiring	46
Single Point Wiring.....	46
Voltage Utilization Range	46
Dual Point Wiring.....	47
Customer Control Wiring	49

TABLE OF CONTENTS (CONT'D)

SECTION 5 - TECHNICAL DATA	61
Nomenclature	61
Elastometric Isolator Installation.....	80
Elastometric Isolator Specifications.....	81
One Inch Deflection Isolator Installation.....	82
One Inch Deflection Spring Isolator Specifications	83
Two Inch Deflection Isolator Installation And Adjustment.....	84
Two Inch Deflection, Restrained Spring Isolator Specifications	85
Elastometric Isolator Installation (GB Certified Units)	86
Elastometric Isolator Specifications (GB Certified Units) Specifications	87
One Inch Deflection Isolator Installation (GB Certified Units).....	88
One Inch Deflection Isolator Installation (GB Certified Units) Specifications	89
Two Inch Deflection Isolator Installation And Adjustment (GB Certified Units).....	90
Two Inch Deflection, Restrained Spring Isolator Specifications (GB Certified Units).....	91
SECTION 6 - COMMISSIONING	93
Preparation.....	93
Inspection	93
Refrigerant Charge.....	93
Correct System Refrigerant Charge.....	93
Service and Oil Line Valves.....	93
Compressor Oil	93
Fans	94
Isolation / Protection.....	94
Control Panel.....	94
Power Connections	94
Grounding.....	94
Water System.....	94
Flow Switch	94
Temperature Sensor(s).....	94
Programmed Options	94
Programmed Settings	94
Date and Time.....	94
Start/Stop Schedule	95
Setpoint and Remote Offset.....	95
First Time Start Up	95
Interlocks.....	95
Unit Switch	95
Startup.....	95
Oil Pressure.....	95
Loading.....	95
Condenser and Fan Rotation	95
System Charge.....	95
General Operation	95
Operation in Sub-freezing Conditions	96
Unit Maintenance and Shutdown in Sub-freezing Conditions	96

TABLE OF CONTENTS (CONT'D)

SECTION 7 - OPERATION	97
Operating Controls	97
Unit Switch	97
Keypad	97
Keypad Data Entry Mode	98
Display.....	98
Anti-recycle Timer.....	98
Evaporator Pump Control.....	98
Evaporator Heater Control	98
Alarms	99
Chiller Run Contact	99
Flow Switch Control.....	99
Remote Run / Stop.....	99
Basic Operating Sequence.....	99
Start Sequence and Loading.....	99
Unit Warning.....	99
Unit Warning Operation.....	99
Low Battery Warning	99
Invalid Number of Compressors Warning.....	100
Invalid Serial Number Warning.....	100
Unit Safeties	100
Unit Safety Operation	100
High Ambient Temp Fault	100
Low Ambient Temp Fault	101
Low Leaving Chilled Liquid Temp Fault.....	101
VSD Communications Failure Fault	101
System Safeties (Faults)	101
System Safety (Fault) Operation	101
High Discharge Pressure Cutout (Software) Fault	102
High Discharge Pressure Cutout (HPCO) (Hardware) Fault	102
Low Suction Pressure Cutout (Software) Fault	102
Low Motor Current Cutout Fault.....	103
High Differential Oil Pressure Cutout Fault	103
Low Differential Oil Pressure Cutout Fault	103
High Discharge Temperature Cutout Fault	103
Low Discharge Superheat Cutout Fault	104
Sensor Failure Cutout Fault	104
High Motor Temperature Cutout Fault	104
System Control Voltage Cutout Fault	105
Eductor Clog Fault.....	105

TABLE OF CONTENTS (CONT'D)

SECTION 8 - MICROPANEL	107
Unit Data Key	110
System Data Keys 1 Through 4.....	112
VSD Data Key	115
Operating Hours / Start Counter Key	116
History Key	117
Setpoints Key	124
Program Key	126
Options Key.....	129
Date/Time and Schedule Keys	132
Manual Override Key.....	135
Print Key.....	136
System Switches Key.....	139
SECTION 9 - MAINTENANCE.....	141
General Requirements	141
Weekly Maintenance	141
Unit Status.....	141
Refrigerant Leaks	141
Operating Conditions.....	141
Compressor Oil Level.....	141
Refrigerant Charge.....	141
Adding Charge to a System	141
Refrigerant Removal, Evacuation and Charging a YVAA Chiller	142
Refrigerant Removal	142
Evacuating a System.....	142
Charging Refrigerant into a System	143
Microchannel Coil Cleaning.....	143
Scheduled Maintenance.....	143
Maintenance Requirements for YVAA Chillers	144
SECTION 10 - DECOMMISSIONING, DISMANTLING AND DISPOSAL	153

LIST OF FIGURES

FIGURE 1 - YVAA Air-Cooled Screw Liquid Chiller with Variable Speed Drive	17
FIGURE 2 - Chiller Control System	18
FIGURE 3 - View of York Control Center User Interface	20
FIGURE 4 - Acceptable Minimum Clearances Around/Between Unit(s)	38
FIGURE 5 - Pipework Arrangement	40
FIGURE 6 - Leaving Water Temperature Out of Range Suggested Layout	40
FIGURE 7 - Suggested Layout For Applications With A Flow Rate Less Than The Evaporator Minimum Allowable Flow Rate	41
FIGURE 8 - Suggested Layout For Applications With A Flow Rate Greater Than The Evaporator Maximum Allowable Flow Rate	41
FIGURE 9 - Victaulic Groove.....	41
FIGURE 10 - Flange For GB Vessels.....	43
FIGURE 11 - Flange Attachment	43
FIGURE 12 - Single Point Power Wiring	46
FIGURE 13 - Dual Point Power Wiring.....	47
FIGURE 14 - Customer Control Connections	49
FIGURE 15 - YVAA Dimensions.....	68
FIGURE 16 - Keyboard and Display.....	97

LIST OF TABLES

TABLE 1 - Unit Rigging	28
TABLE 2 - Minimum Evaporator Tube Removal Clearance.....	38
TABLE 3 - Evaporator Connections Dimensions	42
TABLE 4 - Electrical Lug Data	50
TABLE 5 - Physical Data - Microchannel Coil.....	62
TABLE 6 - Physical Data - Round Tube Coil	66
TABLE 7 - Isolator Selection and Mounting Locations.....	70
TABLE 8 - Low Differential Oil Pressure Cutout	103
TABLE 9 - Start Inhibit Sensor Thresholds	104
TABLE 10 - Sensor Min/Max Outputs	114
TABLE 11 - Setpoint Limits	125
TABLE 12 - Programmable Operating Parameters.....	128
TABLE 13 - Printout Types.....	136
TABLE 14 - Troubleshooting Guide	145
TABLE 15 - Temperature Input Voltage Sensor (Measured Signal To Shield At The Sensor)	148
TABLE 16 - Outside Air Temperature Sensor Input Voltage (Measured Signal To Shield At The Sensor).....	149
TABLE 17 - Pressure Transducer Output Voltage (Measured Signal To Return At The Transducer)	150
TABLE 18 - Motor Temperature Sensor Resistance (Check At The Motor).....	151
TABLE 19 - SI Metric Conversion	155

THIS PAGE INTENTIONALLY LEFT BLANK

SECTION 1 - GENERAL CHILLER INFORMATION AND SAFETY

INTRODUCTION

YORK YVAA chillers are manufactured to the highest design and construction standards to ensure high performance, reliability and adaptability to all types of air conditioning installations.

The unit is intended for cooling water or glycol solutions and is not suitable for purposes other than those specified in this manual.

Rigging and lifting should only be done by a professional rigger in accordance with a written rigging and lifting plan. The most appropriate rigging and lifting method will depend on job specific factors, such as the rigging equipment available and site needs. Therefore, a professional rigger must determine the rigging and lifting method to be used, and it is beyond the scope of this manual to specify rigging and lifting details.

This manual contains all the information required for correct installation and commissioning of the unit, together with operating and maintenance instructions. The manual should be read thoroughly before attempting to operate or service the unit.

All procedures detailed in the manual, including installation, commissioning and maintenance tasks must only be performed by suitably trained and qualified personnel.

The manufacturer will not be liable for any injury or damage caused by incorrect installation, commissioning, operation or maintenance resulting from a failure to follow the procedures and instructions detailed in the manual.

WARRANTY

Johnson Controls warrants YVAA chillers in accordance with the "Limited Warranty Engineered Systems Equipment" procedure, Form 50.05-NM2.

Johnson Controls warrants all equipment and materials against defects in workmanship and materials for a period of eighteen months from date of shipment or 12 months from date of startup, whichever comes first, unless labor or extended warranty has been purchased as part of the contract.

The warranty is limited to parts only replacement and shipping of any faulty part, or sub-assembly, which has failed due to poor quality or manufacturing errors. All

claims must be supported by evidence that the failure has occurred within the warranty period, and that the unit has been operated within the designed parameters specified.

All warranty claims must specify the unit model, serial number, order number and run hours/starts. Model and serial number information is printed on the unit identification plate.

The unit warranty will be void if any modification to the unit is carried out without prior written approval from Johnson Controls.

For warranty purposes, the following conditions must be satisfied:

- The initial start of the unit must be carried out by trained personnel from an authorized Johnson Controls Service Center. Refer to *SECTION 6 - COMMISSIONING* for more information.
- Only genuine YORK approved spare parts, oils, coolants, and refrigerants must be used.
- All the scheduled maintenance operations detailed in this manual must be performed at the specified times by suitably trained and qualified personnel. See *SECTION 9 - MAINTENANCE* for more information.
- Failure to satisfy any of these conditions will automatically void the warranty. Refer to Form 50.05-NM2 for complete details.

QUALITY ASSURANCE AND SAFETY

YVAA chillers are designed within EN ISO 9001 and built within an EN ISO 9002 accredited manufacturing organization.

Units conform with the following European Directives:

- Machinery Directive (2006/42/EC)
- EMC Directive (2004/108/EC)
- Pressure Equipment Directive (97/23/EC)
- Low Voltage Directive (2006/95/EC)
- Safety Code for Mechanical Refrigeration (EN378-2(2008))

CE/PED marked units conform to the following standards:

- Machinery Directive (2006/42/EC).
- EMC Directive (2004/108/EC).
- Pressure Equipment Directive (97/23/EC).
- Low Voltage Directive (2006/95/EC).
- Safety Code for Mechanical Refrigeration (EN378-2(2008)).

ETL/ASME marked units conform to the following standards:

- ANSI/ASHRAE 15 – Safety Code for Mechanical Refrigeration.
- ANSI/ASHRAE 34 – Number Designation and Safety Classification of Refrigerants.
- ANSI/NFPA 70 – National Electrical Code (N.E.C.).
- ASME Boiler and Pressure Vessel Code, Section VIII, Division 1.

GB marked units conform to the following standards:

- GB5226.1 Safety of machinery- Electrical equipment of machines – Part 1: General requirements.
- GB25131 Safety requirements for water chiller (heat pump) using the vapor compression cycle.

FLUORINATED GREENHOUSE GASES

- This equipment contains fluorinated greenhouse gases covered by the Kyoto Protocol.
- The global warming potential of the refrigerant (HFC-134a) used in this unit is 1300.
- The refrigerant quantity is stated in *Table 5 on Page 62* of this document.
- The fluorinated greenhouse gases in this equipment may not be vented to the atmosphere.
- This equipment should only be serviced by qualified technicians.

RESPONSIBILITY FOR SAFETY

Every care has been taken in the design and manufacture of the unit to ensure compliance with the safety requirements listed above. However, the individual rigging, lifting, maintaining, operating or working on any machinery is primarily responsible for:

- Personal safety, safety of other personnel, and the machinery.
- Correct utilization of the machinery in accordance with the procedures detailed in the manual.

ABOUT THIS MANUAL

The contents of this manual include suggested best working practices and procedures. These are issued for guidance only, and they do not take precedence over the above stated individual responsibility and/or local safety regulations.

This manual and any other document supplied with the unit are the property of Johnson Controls which reserves all rights. They may not be reproduced, in whole or in part, without prior written authorization from an authorized Johnson Controls representative.

MISUSE OF EQUIPMENT

Suitability for Application

The unit is intended for cooling water or glycol solutions and is not suitable for purposes other than those specified in these instructions. Any use of the equipment other than its intended use, or operation of the equipment contrary to the relevant procedures may result in injury to the operator, or damage to the equipment.

The unit must not be operated outside the design parameters specified in this manual.

Structural Support

Structural support of the unit must be provided as indicated in these instructions. Failure to provide proper support may result in injury to the operator, or damage to the equipment and/or building.

Mechanical Strength

The unit is not designed to withstand loads or stresses from adjacent equipment, pipework or structures. Additional components must not be mounted on the unit. Any such extraneous loads may cause structural failure and may result in injury to the operator, or damage to the equipment.

General Access

There are a number of areas and features, which may be a hazard and potentially cause injury when working on the unit unless suitable safety precautions are taken. It is important to ensure access to the unit is restricted to suitably qualified persons who are familiar with the

potential hazards and precautions necessary for safe operation and maintenance of equipment containing high temperatures, pressures and voltages.

Pressure Systems

The unit contains refrigerant vapor and liquid under pressure, release of which can be a danger and cause injury. The user should ensure that care is taken during installation, operation and maintenance to avoid damage to the pressure system. No attempt should be made to gain access to the component parts of the pressure system other than by suitably trained and qualified personnel.

Electrical

The unit must be grounded. No installation or maintenance work should be attempted on the electrical equipment without first switching power OFF, isolating and locking-off the power supply. Servicing and maintenance on live equipment must not be attempted. No attempt should be made to gain access to the control panel or electrical enclosures during normal operation of the unit.

Caution:

This equipment (Class A, Group 1) is designed and manufactured for use in an industrial environment, in accordance with EN 61000-6-2:2005 and EN 61000-6-4:2007 (with EN 55011:2007 limits). It is not intended to be used on a low-voltage public network which supplies domestic premises. Radio frequency interference may occur if it is used on a lowvoltage public network.

This equipment equipped with VSD, may generate conducted and radiated disturbances, which may interfere with or damage susceptible connected apparatus.

Generally accepted engineering standards and practices should be followed to ensure trouble-free and EMC compliant electrical installation. Installations must be supervised or completed by a competent person in accordance with EN 13313.

Special considerations depending on the application:

- Industry standard grounding or “earthing” practices for the equipment and installation
- Use of shielded or special cables (power and/or control)
- Use of metallic conduit and/or cable trays for power and control cables connected to equipment

- Cable segregation (in order to avoid the risk of crosstalk or cross interference to signal cables, the power cables shall be segregated from signal cables)
- Dedicated isolation transformer
- Use of additional EMC filters

It is the responsibility of a designated System Integrator to take proper steps assuring the Electromagnetic Compatibility of both equipment and installation as a system.

Rotating Parts

Fan guards must be fitted at all times and not removed unless the power supply has been isolated. If ductwork is to be fitted, requiring the wire fan guards to be removed, alternative safety measures must be taken to protect against the risk of injury from rotating fans.

Sharp Edges

The fins on the air-cooled condenser coils have sharp metal edges. Reasonable care should be taken when working in contact with the coils to avoid the risk of minor abrasions and lacerations. The use of gloves is recommended.

Frame rails, brakes, and other components may also have sharp edges. Reasonable care should be taken when working in contact with any components to avoid risk of minor abrasions and lacerations.

Refrigerants and Oils

Refrigerants and oils used in the unit are generally non-toxic, non-flammable and non-corrosive, and pose no special safety hazards. Use of gloves and safety glasses is, however, recommended when working on the unit. The buildup of refrigerant vapor, from a leak for example, does pose a risk of asphyxiation in confined or enclosed spaces and attention should be given to good ventilation.

Use only the refrigerant specifically designated for the unit. Any other type of refrigerant may cause damage to the equipment and will void the warranty.

High Temperature and Pressure Cleaning

High temperature and pressure cleaning methods (e.g. steam cleaning) should not be used on any part of the pressure system as this may cause operation of the pressure relief device(s). Detergents and solvents, which may cause corrosion, should also be avoided.

Emergency Shutdown

In case of emergency, the control panel is fitted with an incoming supply circuit breaker with a red and yellow handle which can be used as the emergency stop device. When operated it removes the electrical supply to the inverter, fans, and control circuit thus shutting down the unit.

Safety Labels



White symbol on blue background.

For safe operation, read the Instructions first.



Black symbol on yellow background.

Warning: This machine may start automatically without prior warning



Black symbol on yellow background.

Warning: Hot surface.



Black symbol on yellow background.

Warning: Safety relief valve may discharge gas or liquid without prior warning.



Black symbol on yellow background.

Warning: Isolate all electrical sources of supply before opening or removing the cover, as lethal voltages may exist.



Black symbol on yellow background.

General attention symbol.



Black symbol on yellow background.

Warning: On isolating the supply it may take up to 300 seconds for the capacitor voltage to fall below 50 volts.

SECTION 2 - PRODUCT DESCRIPTION

YORK YVAA HFC-134a chillers are designed for water or glycol cooling. All units are designed to be located outside on the roof of a building or at ground level.

The units are completely assembled with all interconnecting refrigerant piping and internal wiring, ready for field installation.

Prior to delivery, the unit is pressure tested, evacuated, and fully charged with refrigerant and oil in each of the two independent refrigerant circuits. After assembly, an operational test is performed with water flowing through the evaporator to ensure that each refrigerant circuit operates correctly.

The unit structure is manufactured from heavy gauge, galvanized steel. Many external structural parts are coated with “Champagne” baked-on enamel powder paint.

All exposed power wiring is routed through liquid-tight, non-metallic conduit.

GENERAL SYSTEM DESCRIPTION

The YVAA Chiller combines the best of modern screw compressor design with the latest technology in vari-

able speed drives. The result is superior control and efficiency in real world conditions. The VSD enables slowing the speed of the compressor to match the load on the system resulting in precise chilled liquid control, minimized sound, maximum energy efficiency, and reduced cost of ownership. The VSD also provides soft starts with no electrical inrush. The lack of heat build-up on start also enables required off time between starts to be reduced to a period of two minutes.

The YVAA Air-Cooled Screw Chiller utilizes many components, which are the same or nearly the same as a standard screw chiller of a similar size. This includes modular frame rails, condenser, fans, compressors and evaporator.

The chiller consists of two screw compressors in a corresponding number of separate refrigerant circuits, a hybrid falling film evaporator, an air-cooled condenser, receiver/flash tanks, feed valves, oil separators, and compressor mufflers. Oil separators utilize no moving parts. Oil cooling is accomplished by refrigerant leaving the eductor flashing in the suction line which cools the oil, motor and compressor.

2



LD15045

FIGURE 1 - YVAA AIR-COOLED SCREW LIQUID CHILLER WITH VARIABLE SPEED DRIVE

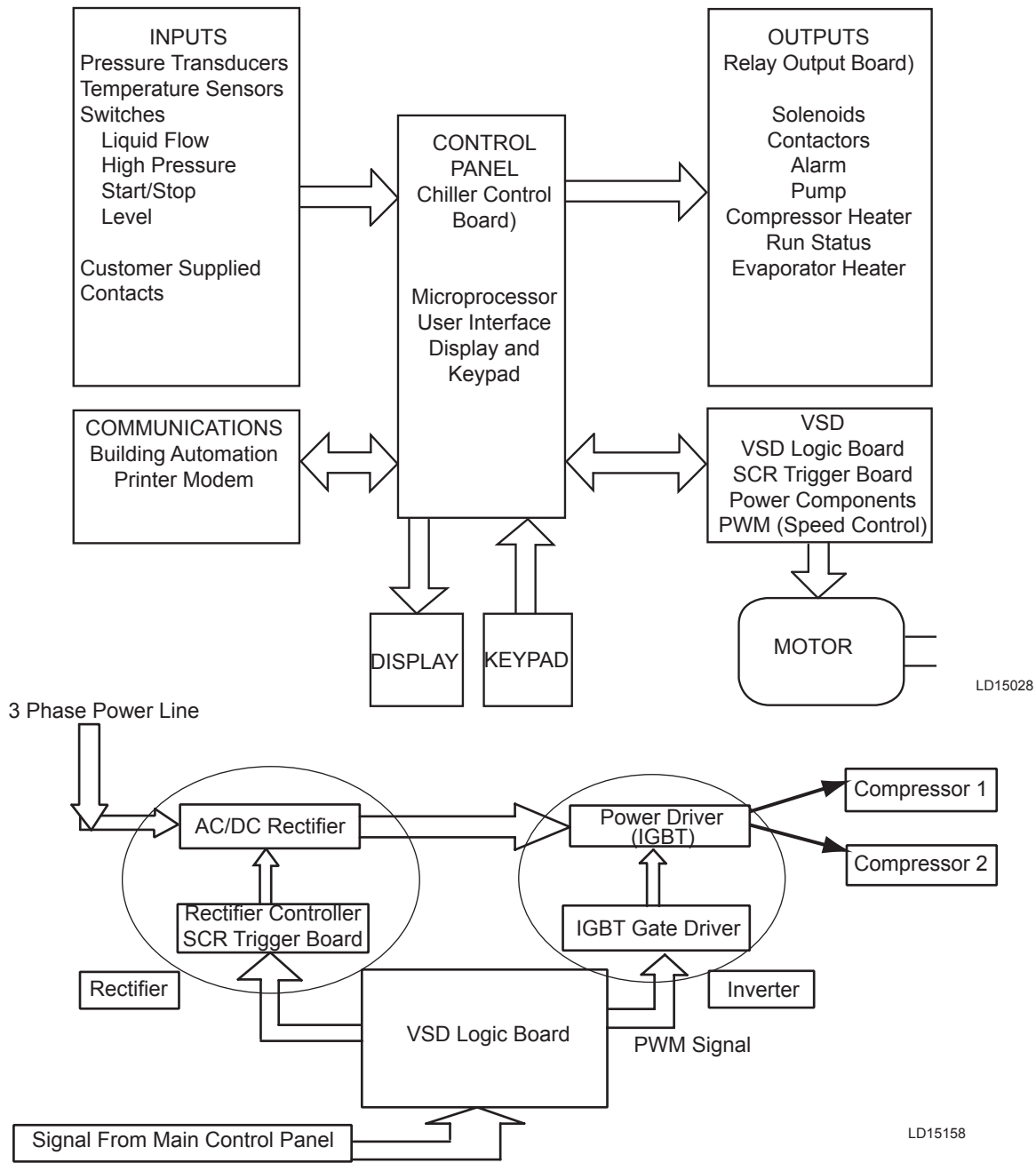

FIGURE 2 - CHILLER CONTROL SYSTEM

An integral liquid cooled, transistorized, PWM, Variable Speed Drive (VSD) is controlled by the chiller microprocessor control panel to start/stop, select compressors to run, and select compressor speed. Displacement Power Factor is 0.95 at part or full load.

The chiller microprocessor communicates with the VSD Logic Board via a 3-wire RS-485 opto coupled data link. The VSD Logic Board runs the number of compressors required to meet the load and the compressors to the speed requested by the chiller microprocessor.

The basic system control and VSD system architecture is shown in *Figure 2 on Page 18*.

SEMI-HERMETIC YORK TWIN-SCREW COMPRESSORS

Compressors are direct drive, semi-hermetic, rotary twin-screw type, including: muffler, temperature actuated ‘off-cycle’ heater, IP55 terminal board and precision machined cast iron housing.

Reliable suction gas cooled, high efficiency, accessible hermetic compressor motor, full suction gas flow

through mesh screen filter, with inherent internal thermal overload protection and external current overload on all three phases.

Continuous function, microprocessor controlled, Variable Speed Drive (VSD) shall provide valve-less, smooth capacity control from 100% down to 10% of chiller capacity.

In addition, elimination of the slide valve and associated unloading components has resulted in a 50% reduction in compressor moving parts.

EVAPORATOR

The evaporator is a shell and tube, hybrid falling film type heat exchanger. It contains a balance of flooded and falling film technology to optimize efficiency, minimize refrigerant charge, and maintain reliable control. A specifically designed distribution system provides uniform refrigerant flow for optimum performance.

CONDENSER

The YVAA introduces micro-channel coil to the York screw compressor chiller line. The micro-channel maximizes condenser heat transfer, resulting in a smaller footprint, and reduces refrigerant charge by as much as 50%.

Each condenser coil is a single piece all aluminum construction including headers, tubes and fins to avoid galvanic corrosion due to dissimilar metals. Coils and headers are brazed as one piece. Integral sub-cooling is included. The design working pressure is 25.9 barg.

Multiple, standard low sound, high efficiency, TEAO motor driven fans move air through the coils. They are dynamically and statically balanced, direct drive with corrosion-resistant glass fiber reinforced composite blades molded into low-noise, full airfoil cross sections, providing vertical air discharge from extended orifices for efficiency and low sound.

Fan motors are Totally Enclosed Air-Over (TEAO), squirrel-cage type and current protected. The direct drive motors feature double-sealed and permanently lubricated ball bearings, cutting down on maintenance cost over the life of the unit.

REFRIGERANT CIRCUIT

An independent refrigerant circuit is provided per compressor. Each circuit uses copper refrigerant pipe formed on computer controlled bending machines to

reduce the number of brazed joints resulting in a reliable and leak resistant system.

- Discharge lines are provided with a manual compressor shutoff service valve (See *Accessories and Options on Page 21* for suction line service valve).
- The external oil separators, with no moving parts and designed for minimum oil carry-over, are mounted in the discharge line of the compressor.
- Liquid line components include: high absorption removable core filter-drier, sight glasses with moisture indicators, manual shut-off valve with charging port, orifice and electronic expansion valve.
- An economizer (flash) tank is located in each refrigerant circuit to increase the system efficiency.

ELECTRICAL

Johnson Controls has over 25 years of experience designing variable -speed drives specifically for chiller applications. The result is an extremely reliable air-cooled chiller system that offers industry leading efficiency at real world operating conditions, valve-less compressor loading/unloading, excellent capacity control, high power factor and soft start..

Incoming single point power is standard utilizing a lockable circuit breaker, 115VAC control transformer, VSD, fan contactors, ON/OFF unit switch, microcomputer keypad and display, Chiller Control and VSD Logic boards, and relay boards.

Standard design includes IP55 rating, powder painted steel cabinet with hinged, latched, and gasket sealed outer doors equipped with wind struts for safer servicing. The panel includes a control display access door so that display and control features can be accessed without opening main cabinet doors.

All exposed power wiring is routed through liquid-tight, UV-stabilized, non-metallic conduit.

BUILDING AUTOMATION SYSTEM CAPABILITIES

The E-Link Gateway provides an economical and versatile connection between York equipment and open/standard protocols. It efficiently manages the communication protocols currently used by York equipment, exposing the data in a consistent, organized, and defined fashion. The E-Link Gateway is available as a

field-installed option on YVAA. A simple switch selection allows configuration of the required equipment profile and output protocol, which reduces equipment connectivity startup time.

MICROCOMPUTER CONTROL CENTER

The microcomputer control center (see *Figure 3 on Page 20*) provides automatic control of chiller operation including compressor start/ stop and load/unload anti-recycle timers, condenser fans, evaporator pump, evaporator heater, unit alarm contacts and run signal contacts. The microcomputer control center comes online as soon as the main power switch on the unit is switched on; immediately, the microcomputer control center will begin to check all variables with a frequency ranging from 30 seconds to almost continuous monitoring.

The microprocessor controls the unit's capacity by matching the actual leaving chilled water temperature (LCWT) to the user-defined setpoint. Factors that may cause the system's actual LCWT to fluctuate are changes in ambient temperature, loop flow rate, load, and loop volume. The control system reacts to such changes by adjusting the number of compressors that are on and the loading of each compressor in order to keep the LCWT at the setpoint.

The control system logic monitors the rate at which the LCWT is approaching the setpoint to ramp up or down compressor capacity as required. The variable frequency drive allows the compressor capacity to match the load.

Display Data

- Leaving Chilled Liquid Temperature
- Returning Liquid Temperature
- Ambient Temperature
- Lead System
- Compressor Capacity (% of Full Load Amps)
- VSD Output Frequency / Compressor Speed
- Compressor Run Hours
- Compressor Number of Starts
- Oil Pressure and Temperature (per Compressor)
- Evaporator Pump Status
- Evaporator Heater Status
- History Data for Last Twenty Normal Shutdowns
- History Data for Last Ten Shutdown Faults

Programmable Setpoints

- Chiller On/Off
- Chilled Liquid (Water or Glycol)
- Local or Remote Control
- Units of Measure (Imperial or SI)
- System Lead / Lag
- Remote Temperature Reset
- Remote Current Limit
- Leaving Chilled Liquid Temperature Setpoint and Range

Johnson Controls' systems or another vendor's systems can incorporate these setpoints and data outputs to give the customer a complete understanding of how the system is running through a Building Automation System.

Extreme Conditions – During extreme or unusual conditions (i.e. blocked condenser coils, ambient above scheduled maximum, etc.) the chiller control system will avoid shutdown by varying capacity. By monitoring motor current and suction and discharge pressures, the chiller can maintain maximum available cooling output without shutting down.

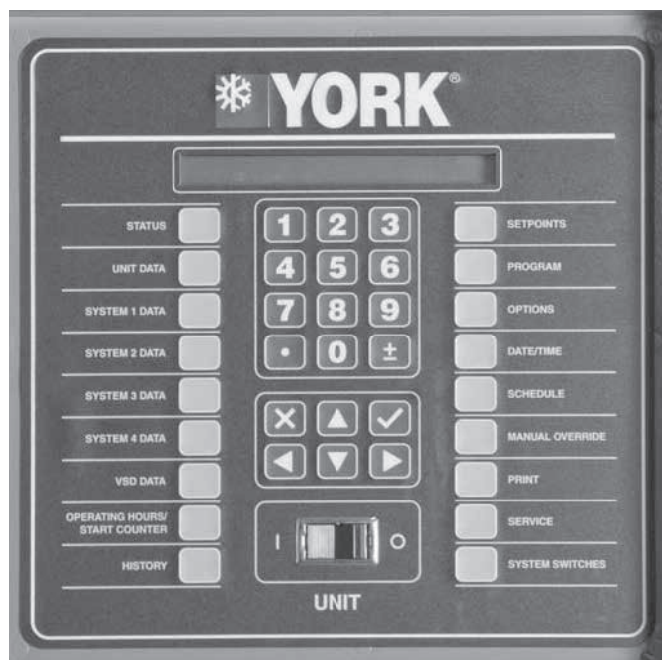

FIGURE 3 - VIEW OF YORK CONTROL CENTER USER INTERFACE

Unit Safeties are provided for the chiller to perform auto-reset shut down for the following conditions:

- Ambient temperature above or below allowable range
- Out of range leaving chilled liquid temperature
- Under voltage
- Flow switch operation

ACCESSORIES AND OPTIONS

All options factory mounted unless otherwise noted.

Sound Attenuation

Low Noise Kits – The standard chiller configuration is equipped with low sound fans and acoustic treatments on the refrigerant lines and compressors. There are several sound attenuation options available to further reduce sound at its source thereby meeting local sound level regulations.

SilentNight™ – Due to time of day based sound regulations in some locations it may be desirable to force the chiller to a lower sound level on demand. The SilentNight control option provides a control input to limit sound output of the chiller based on time of day. This feature is programmable at the chiller panel or can be controlled remotely via a signal (4-20mA or 0-10VDC) from a BAS system.

FAN OPTIONS

Ultra Quiet Fans – The chiller is equipped with specially designed fans and motors to provide lower sound levels yet retain appropriate airflow. The result is reduced fan generated sound with minimal effect on the chiller capacity or efficiency.

High Static Fans – The chiller is equipped with condenser fans with higher power motors suitable for high external static pressure, up to 100 Pa (0.4 in. water), across condenser coils. This option should be selected if additional airflow resistance may be present due to flow restrictions such as field installed ducts, filters, sound enclosures etc. Please contact your local JCI representative for more information.

High Airflow Fans – The chiller is equipped with condenser fans with airfoil type blades and high power motors providing extra airflow across coils. In some chiller configurations, this option can provide an increase in chiller capacity at high ambient. The high airflow fans are also available with variable speed control. Please contact your local JCI representative for more information.

CONDENSER COILS

Fin and tub condenser coils of seamless, internally-enhanced, high-condensing-coefficient, corrosion resistant copper tubes are arranged in staggered rows. The tubes are mechanically expanded into aluminum fins. Integral subcooling is included. The design working pressure of the coils is 350 PSIG (24 barg).

Condenser Coil Protection

The aluminum alloys used in the YVAA micro-channel condenser have been carefully selected and tested for high corrosion resistance. However, all metals can corrode in harsh conditions. Consider protecting coils from corrosive environments such as coastal, marine, urban and industrial.

Post-Coated Epoxy Dipped Condenser – Micro-channel condenser coils applied with electro-deposited and baked flexible epoxy coating that is finished with a polyurethane UV resistant top-coat suitable for highly corrosive applications.

Protective Chiller Panels

Wire Panels – UV stabilized black polyvinyl chloride coated, heavy gauge, welded wire mesh guards mounted on the exterior of the full unit. Protects condenser coil faces and prevents unauthorized access to refrigerant components (compressors, pipes, evaporator, etc.), yet provides free air flow. This can cut installation cost by eliminating the need for separate, expensive fencing.

Louvered Panels – Louvered panels, painted the same color as the unit, enclose the unit to visually screen and protect the coils as well as preventing unauthorized access to internal components. Also available as a condenser-only option.

Louvered/Wire Panels Combination – Louvered panels, painted the same color as the unit, are mounted on external condenser coil faces. Heavy gauge, welded wire-mesh panels, coated to resist corrosion, are mounted around base of machine to restrict unauthorized access.

End Hail Guard – Louvered panels, painted the same color as the unit, are installed on the rear of the unit (opposite end of the control panel) to protect the exposed condenser from flying debris or hail.

V-Guard Panels – Solid panels, painted the same color as the unit, are installed along the sides of the units to cover exposed piping within the condenser section without impacting airflow. These guard panels can be combined with End Hail Guard option for additional protection from debris.

Evaporator Options

38 mm insulation – Double thickness insulation provided.

Flange Kit – Provides contractor with the couplings best suited to tie into the chilled water piping. All flanges are PN10.

Connection Location – The standard unit configuration is available with fluid inlet connections at rear (opposite control panel end) of unit. Option available for front fluid inlet on select configurations.

Water Box Heater – The standard unit comes with evaporator shell heaters and water pump control software. Optional water box heaters are required for storage below 0°F (-17°C). Refer to the Refrigerant Valve - Off option on *page 96* for more information on freeze protection.

Controls Options

High Ambient Operation – This provides special control logic coupled with high airflow fans to permit high ambient up to 52°C (125°F) operation. Fans are airfoil type blades with high power motors. This option may also allow for increased machine capacity, allowing the selection of a smaller chassis to meet specific capacity requirements.

Building Automation System Interface (Temperature) – Factory installed option to accept a 4 to 20mA or a 0 to 10VDC input to allow remote reset of the Leaving Chilled Liquid Temperature Setpoint. The setpoint can be positively offset upwards up to 22.2°C (40°F). This option is useful for ice storage or process applications or for periods where higher chilled liquid temperatures are adequate for low loads. Available alone or in combination with BAS Load Limit.

Building Automation System Interface (Load Limit) – Factory installed option to accept a 4 to 20mA or a 0 to 10VDC input to allow remote reset of the Load Limit Setpoint. The setpoint can limit system demand from 30-100%. Available alone or in combination with BAS Temperature Reset.

E-Link – The optional E-Link gateway provides communication between the equipment and Building Automation Systems, including BACnet (MS/TP), Modbus, LON and N2.

Thermal Storage – Provides special control logic and modifications to produce leaving chilled brine temperatures below 4.4°C (40°F) primarily at times of low ambient temperatures (night time). Option can be used to produce ice to supplement cooling and significantly decrease energy costs. The capability of the chiller is enhanced by using both ice and chilled water simultaneously during times of peak cooling needs.

General Options

Flow Switch Accessory – Vapor proof SPDT, NEMA 3R switch, 10.3 barg (150 psig) DWP, -29°C to 121°C (-20°F to 250°F) with 1" NPT (IPS) connection for upright mounting in horizontal pipe. This flow switch or equivalent must be furnished with each unit. **Field mounted.**

Differential Pressure Switch – This 0.2-3 barg (3-45 psig) range switch, with 1/4" NPTE pressure connections, is an alternative to the paddle-type flow switch. **Field mounted.**

Service Isolation Valve – Service suction isolation valve added to unit for each refrigerant circuit.

Dual Pressure Relief Valve – Two safety relief valves are mounted in parallel; one is always operational to assist in valve replacement during maintenance.

Terminal Block [not available for CE marked units] – Terminal Block connections shall be provided at the point of incoming single point connection for field connection and interconnecting wiring to the compressors. Separate external protection must be supplied, by others, in the incoming power wiring, which must comply with local codes.

Circuit Breaker – A unit-mounted circuit breaker with external lockable handle will be supplied to isolate the single point power voltage for servicing. The circuit breaker is sized to provide motor branch circuit protection, short circuit protection and ground fault protection for the motor branch-circuit conductors, the motor control apparatus and the motors.

Non-Fused Disconnect Switch – Unit-mounted disconnect switch with external lockable handle can be supplied to isolate the unit power voltage for servicing. Separate external fusing must be supplied by the power wiring, which must comply with local codes.

Vibration Isolation

Elastomeric Isolation – This option is recommended for normal installations. It provides very good performance in most applications for the least cost. **Field mounted.**

25 mm (1") Spring Isolators – Spring and cage type isolators for mounting under the unit base rails are available to support unit. They are level adjustable. 25 mm (1") nominal deflection may vary slightly by application. **Field mounted.**

50 mm (2") Restrained Spring Isolators – Restrained Spring-Flex Mounting isolators incorporate a rugged welded steel housing with vertical and horizontal limit stops. Housings designed to withstand a minimum 1.0g accelerated force in all directions up to 51 mm (2"). The deflection may vary slightly by application. They are level adjustable. **Field mounted.**

THIS PAGE INTENTIONALLY LEFT BLANK

SECTION 3 - RIGGING, HANDLING AND STORAGE



WARNING

Failure to follow these instructions could result in death, serious injury or equipment damage.

Follow all warnings and instructions in the unit's Manual(s).

EN Installation Instructions for the technician / fitter	IT Istruzioni d'installazione per il personale specializzato	JA 一般仕様・取扱説明書
PL Instrukcja instalacji dla technika / monter	NL Installatiehandleiding voor de vakman / monteur	FR Manuel d'installation pour le spécialiste / monteur
SV Installationsguide för installator / montör	DE Installationsanleitung für die Fachkraft / Monteur	RU Инструкция по установке для техника/монтажника
CS Pokyny k instalaci pro techniky a montéry	ES Instrucciones de instalación para el técnico / contratista especializado	ZH 适用于技术人员与安装人员的 安装说明书



1. Follow all applicable regulations and safety practices during rigging and lifting.
2. Prepare and follow written rigging and lifting plan.
3. Rigging must be directed by trained professional rigger.
4. Spreader bars must be used and be long enough to prevent rigging from contacting unit.
5. Use all and only designated lift points according to units manual(s).
6. Locate center of gravity through trial lifts to account for possible variations in unit configuration.
7. Use rigging and lifting techniques that keep unit stable and level.
8. Keep clear of unit when lifted.

035-23962-000 REV A

LD19197



Rigging and lifting should only be done by a professional rigger in accordance with a written rigging and lifting plan. The most appropriate rigging and lifting method will depend on job specific factors, such as the rigging equipment available and site needs. Therefore, a professional rigger must determine the rigging and lifting method to be used, and it is beyond the scope of this manual to specify rigging and lifting details.

LIFTING WEIGHTS

Refer to the unit nameplate for unit shipping weight. Note that weight may vary depending on unit configuration at the time of lifting. Refer to the Physical Data tables within this manual for further information regarding shipping and operating weights.

DELIVERY AND STORAGE

To ensure consistent quality and maximum reliability, all units are tested and inspected before leaving the factory. Units are shipped completely assembled and containing refrigerant under pressure. Units are shipped without export crating unless crating has been specified on the Sales Order.

If the unit is to be put into storage, prior to installation, the following precautions should be observed:

- The chiller must be “blocked” so that the base is not permitted to sag or bow.
- Ensure that all openings, such as water connections, are securely capped.
- Do not store where exposed to ambient air temperatures exceeding 43°C (110°F).

- The condensers should be covered to protect the coils and fins from potential damage and corrosion, particularly where building work is in progress.
- The unit should be stored in a location where there is minimal activity in order to limit the risk of accidental physical damage.
- To prevent inadvertent operation of the pressure relief devices the unit must not be steam cleaned.
- It is recommended that the unit is periodically inspected during storage.

INSPECTION

Remove any transit packing and inspect the unit to ensure that all components have been delivered and that no damage has occurred during transit. If any damage is evident, it should be noted on the carrier's freight bill and a claim entered in accordance with the instructions given on the advice note.

Major damage must be reported immediately to your local Johnson Controls representative.

MOVING THE CHILLER

Prior to moving the unit, ensure that the installation site is suitable for installing the unit and is easily capable of supporting the weight of the unit and all associated services.



The unit must only be lifted by the base frame at the points provided. Never move the unit on rollers, or lift the unit using a forklift truck.

Care should be taken to avoid damaging the condenser cooling fins when moving the unit.

UNIT REMOVAL FROM SHIPPING CONTAINER

1. Place a clevis pin into the holes provided at the end of each base rail on the unit. Attach chains or nylon straps through the clevis pins and hook onto a suitable lift truck for pulling the unit out of the container.
2. Slowly place tension on the chains or straps until the unit begins to move and then slowly pull the unit from the container. Be sure to pull straight so the sides do not scrape the container.
3. Place a lifting fixture on the forks of the lift truck and reattach the chain or strap. Slightly lift the front of the unit to remove some weight from the floor of the container. Continue pulling the unit with an operator on each side to guide the lift truck operator.
4. Pull the unit until the lifting locations are outside of the container. Place 4 X 4 blocks of wood under the base rails of the unit. Gently rest the unit on the blocks and remove the chains and lift truck.
5. Attach lifting rigging from the crane and slowly complete the removal from the container then lift up and away.



LD19197a

LIFTING USING LUGS

Units are provided with lifting holes in the base frame which accept the accessory lifting lug set as shown in the figure below. The lugs (RH and LH) should be inserted into the respective holes in the base frame and turned so that the spring loaded pin engages into the hole and the flanges on the lug lock behind the hole. The lugs should be attached to the cables/chains using shackles or safety hooks.

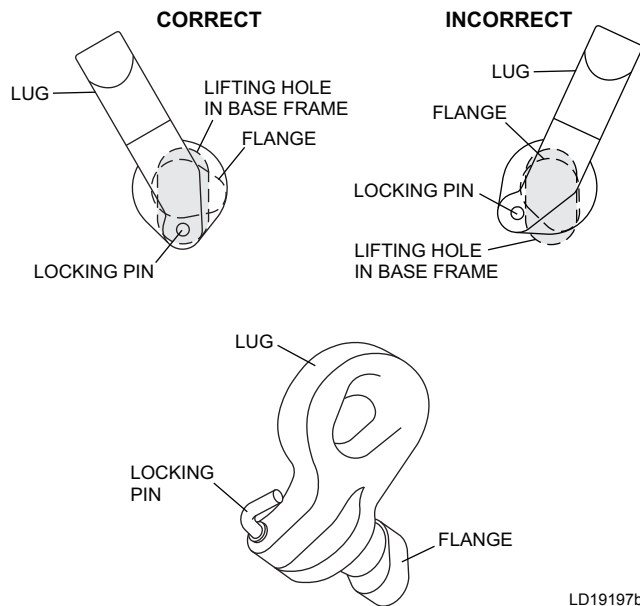

LD19197b

LIFTING USING SHACKLES

The shackles should be inserted into the respective holes in the base frame and secured from the inside.

Use spreader bars to avoid lifting chains hitting the chiller. Various methods of spreader bar arrangements may be used, keeping in mind the intent is to keep the unit stable and to keep the chains from hitting the chiller and causing damage.

Never lift the chiller using a forklift or by hooking to the top rails. Use only the lifting holes provided.

Lifting Instructions are placed on a label on the chiller and on the shipping bag.

THIS PAGE INTENTIONALLY LEFT BLANK

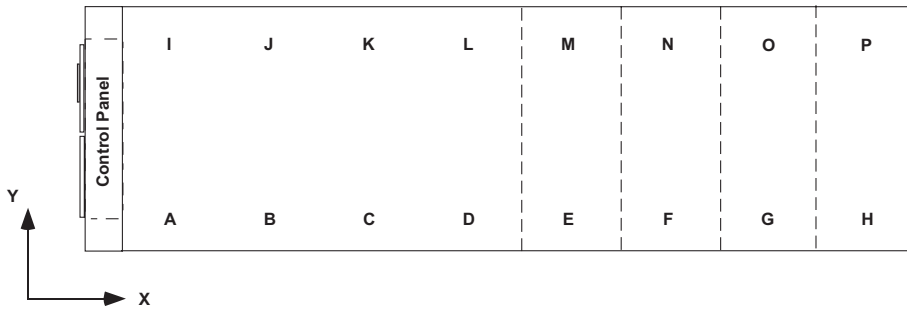

TABLE 1 - UNIT RIGGING

YVAA MODEL			DESCRIPTION	UNITS	RIGGING HOLES								APPOX. CENTER OF GRAVITY ¹	
FRAME	COND	EVAP			A	B	C	D	E	F	G	H	X (IN)	Y (IN)
015	3	B	Rigging Hole Location	inches	18	60	116	192					102	44
				mm	464	1512	2937	4866					2578	1122
			Point Load ¹	lbs	1035	1676	1676	1372						
				kgs	470	760	760	622						
016	5	B	Rigging Hole Location	inches	18	60	137	214					126	44
				mm	464	1533	3482	5435					3206	1122
			Point Load ¹	lbs	624	1139	3081	1198						
				kgs	283	516	1397	543						
017	8	C	Rigging Hole Location	inches	12	73	144	197	260				144	44
				mm	314	1845	3654	5012	6593				3649	1122
			Point Load ¹	lbs	625	1746	2573	1287	1103					
				kgs	283	792	1167	584	501					
018	3	A	Rigging Hole Location	inches	18	60	143	220					128	44
				mm	464	1533	3636	5598					3248	1122
			Point Load ¹	lbs	504	1448	2890	1142						
				kgs	229	657	1311	518						
019	5	A	Rigging Hole Location	inches	18	60	143	227	272				139	44
				mm	464	1533	3636	5761	6920				3523	1122
			Point Load ¹	lbs	469	1474	2778	1389	256					
				kgs	213	669	1260	630	116					
019	8	B	Rigging Hole Location	inches	18	60	137	215	302				148	44
				mm	464	1533	3484	5455	7670				3760	1122
			Point Load ¹	lbs	416	1628	2445	1657	717					
				kgs	189	738	1109	751	325					
020	0	C	Rigging Hole Location	in.	18	60	131	214					114	46
				mm.	464	1518	3332	5430					2907	1168
			Point Load ¹	lbs.	1199	750	3466	1280						
				kg.	544	340	1572	581						
021	3	A	Rigging Hole Location	inches	18	60	143	227	272				139	44
				mm	464	1533	3637	5761	6920				3530	1122
			Point Load ¹	lbs	472	1467	2822	1411	257					
				kgs	214	665	1280	640	117					
021	5	C	Rigging Hole Location	inches	12	73	144	197	260				150	44
				mm	314	1845	3654	5012	6593				3806	1122
			Point Load ¹	lbs	480	1988	1988	1688	1314					
				kgs	218	902	902	766	596					
021	8	C	Rigging Hole Location	inches	12	73	163	254	324				153	44
				mm	314	1845	4144	6443	8218				3889	1122
			Point Load ¹	lbs	518	2344	3047	1501	428					
				kgs	235	1063	1382	681	194					

NOTE: Weights and approximate center of gravity location shown for base unit. Any options selected may add weight to the unit and affect the center of gravity. Locate the center of gravity through trial lifts to account for possible variations in unit configuration. Contact your nearest Johnson Controls Sales Office for weight data.

¹ Microchannel condenser coils only

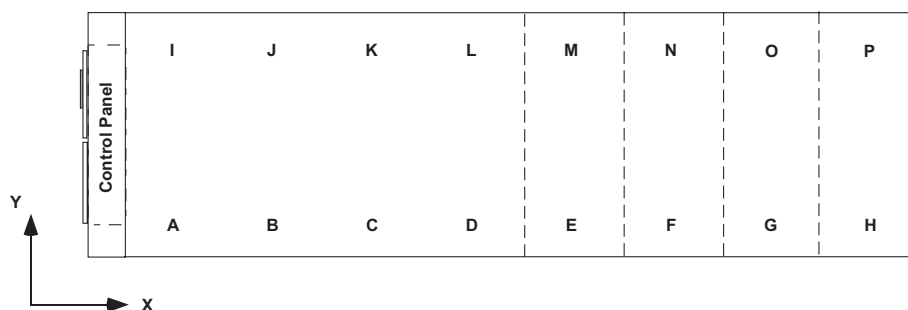

TABLE 1 - UNIT RIGGING (CONT'D)

YVAA MODEL			DESCRIPTION	UNITS	RIGGING HOLES							APPOX. CENTER OF GRAVITY ¹			
FRAME	COND	EVAP			I	J	K	L	M	N	O	P	X (IN)	Y (IN)	
015	3	B	Rigging Hole Location	inches	18	60	116	192					102	44	
				mm	464	1511	2937	4866						2578	1122
			Point Load ¹	lbs	951	1656	1656	1495							
				kgs	431	75	751	678							
016	5	B	Rigging Hole Location	inches	18	60	137	214					126	44	
				mm	464	1533	3485	5435						3206	1122
			Point Load ¹	lbs	606	1120	3057	1259							
				kgs	275	508	1387	571							
017	8	C	Rigging Hole Location	inches	12	73	144	197	260				144	44	
				mm	314	1845	3654	5012	6593					3649	1122
			Point Load ¹	lbs	634	1612	2611	1305	1172						
				kgs	288	731	1184	592	532						
018	3	A	Rigging Hole Location	inches	18	60	143	220					128	44	
				mm	464	1533	3636	5598						3248	1122
			Point Load ¹	lbs	510	1416	2917	1192							
				kgs	231	642	1323	541							
019	5	A	Rigging Hole Location	inches	18	60	143	227	272				139	44	
				mm	464	1533	3636	5761	6920					3523	1122
			Point Load ¹	lbs	484	1422	2831	1416	264						
				kgs	219	645	1284	642	120						
019	8	B	Rigging Hole Location	inches	18	60	137	215	302				148	44	
				mm	464	1533	3484	5455	7670					3760	1122
			Point Load ¹	lbs	396	1631	2453	1716	717						
				kgs	180	740	1113	779	325						
020	0	C	Rigging Hole Location	inches	60	131	214						114	46	
				mm	1518	3332	5430							2907	1168
			Point Load ¹	lbs	776	3428	1384								
				kgs	352	1555	628								
021	3	A	Rigging Hole Location	inches	18	60	143	227	272				139	44	
				mm	464	1533	3637	5761	6920					3530	1122
			Point Load ¹	lbs	484	1419	2841	1420	264						
				kgs	220	644	1288	644	120						
021	5	C	Rigging Hole Location	inches	12	73	144	197	260				150	44	
				mm	314	1845	3654	5012	6593					3806	1122
			Point Load ¹	lbs	472	1935	1935	1736	1379						
				kgs	214	878	878	788	626						
021	8	C	Rigging Hole Location	inches	12	73	163	254	324				153	44	
				mm	314	1845	4144	6443	8218					3889	1122
			Point Load ¹	lbs	510	2282	2967	1743	336						
				kgs	231	1035	1346	791	152						

NOTE: Weights and approximate center of gravity location shown for base unit. Any options selected may add weight to the unit and affect the center of gravity. Locate the center of gravity through trial lifts to account for possible variations in unit configuration. Contact your nearest Johnson Controls Sales Office for weight data.

¹ Microchannel condenser coils only

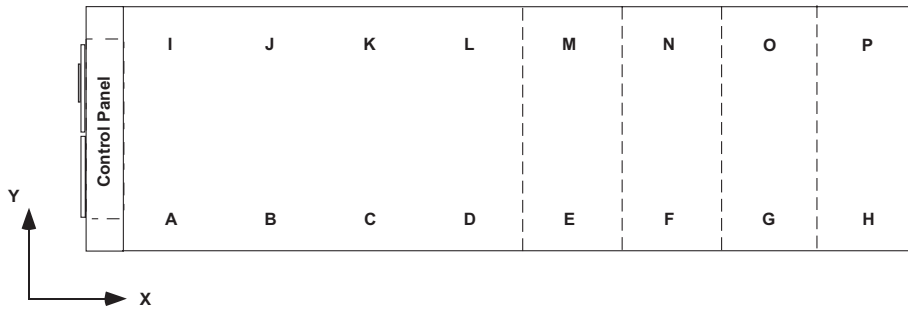

TABLE 1 - UNIT RIGGING (CONT'D)

YVAA MODEL			DESCRIPTION	UNITS	RIGGING HOLES								APPOX. CENTER OF GRAVITY ¹		
FRAME	COND	EVAP			A	B	C	D	E	F	G	H	X \ (IN)	Y \ (IN)	
023	3	B	Rigging Hole Location	inches	18	60	137	215	272				102	44	
				mm	464	1533	3485	5456	6919				2578	1122	
			Point Load ¹	lbs	340	2054	2049	2049	143						
				kgs	154	932	929	929	65						
024	5	C	Rigging Hole Location	inches	18	60	149	240	324				152	44	
				mm	464	1533	3789	6088	8218				3851	1122	
			Point Load ¹	lbs	358	2130	2982	2151	307						
				kgs	162	966	1352	975	139						
024	8	C	Rigging Hole Location	inches	12	73	163	254	347				169	44	
				mm	314	1845	4144	6443	8825				4289	1122	
			Point Load ¹	lbs	697	1921	3078	1741	871						
				kgs	316	871	1396	790	395						
026	3	B	Rigging Hole Location	inches	18	60	137	215	302				146	44	
				mm	464	1533	3484	5455	7670				3721	1122	
			Point Load ¹	lbs	513	1610	2517	1681	717						
				kgs	233	730	1142	763	325						
027	3	D	Rigging Hole Location	inches	12	73	121	181	264	324			168	44	
				mm	314	1845	3073	4601	6717	8217			4259	1122	
			Point Load ¹	lbs	877	553	1442	3605	1108	554					
				kgs	398	251	654	1635	502	251					
027	5	E	Rigging Hole Location	inches	12	73	121	181	264	324			168	44	
				mm	314	1845	3073	4601	6717	8218			4274	1122	
			Point Load ¹	lbs	872	569	1524	3811	1146	573					
				kgs	396	258	691	1729	520	260					
027	8	E	Rigging Hole Location	inches	12	73	121	181	243	347			178	44	
				mm	314	1845	3073	4601	6169	8825			4525	1122	
			Point Load ¹	lbs	616	1372	1138	2845	1937	968					
				kgs	280	622	516	1290	878	439					
029	5	E	Rigging Hole Location	inches	12	73	179	290	347				177	44	
				mm	314	1845	4551	7358	8825				4495	1122	
			Point Load ¹	lbs	500	1930	4518	1506	533						
				kgs	227	875	2049	683	242						
030	3	C	Rigging Hole Location	inches	12	73	161	254	347				168	44	
				mm	314	1845	4092	6443	8825				4256	1122	
			Point Load ¹	lbs	747	1875	3196	1749	874						
				kgs	339	850	1450	793	397						

NOTE: Weights and approximate center of gravity location shown for base unit. Any options selected may add weight to the unit and affect the center of gravity. Locate the center of gravity through trial lifts to account for possible variations in unit configuration. Contact your nearest Johnson Controls Sales Office for weight data.

¹ Microchannel condenser coils only

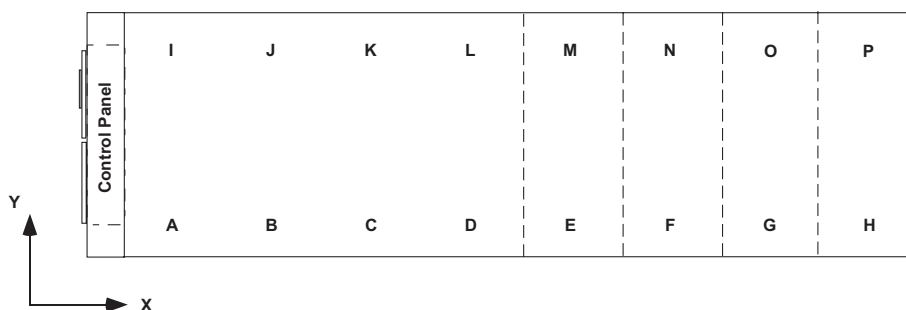

TABLE 1 - UNIT RIGGING (CONT'D)

YVAA MODEL			DESCRIPTION	UNITS	RIGGING HOLES								APPOX. CENTER OF GRAVITY ¹		
FRAME	COND	EVAP			I	J	K	L	M	N	O	P	X (IN)	Y (IN)	
023	3	B	Rigging Hole Location	inches	18	60	137	215	272				135	44	
				mm	464	1533	3485	5456	6919				3418	1122	
			Point Load ¹	lbs	329	2038	2067	2067	151						
				kgs	149	925	938	938	69						
024	5	C	Rigging Hole Location	inches	18	60	149	240	324				152	44	
				mm	464	1533	3789	6088	8218				3851	1122	
			Point Load ¹	lbs	354	2079	2911	2340	261						
				kgs	160	943	1320	1061	118						
024	8	C	Rigging Hole Location	inches	12	73	163	254	347				169	44	
				mm	314	1845	4144	6443	8825				4289	1122	
			Point Load ¹	lbs	697	1800	3169	1773	886						
				kgs	316	817	1437	804	402						
026	3	B	Rigging Hole Location	inches	18	60	137	215	302				146	44	
				mm	464	1533	3484	5455	7670				3721	1122	
			Point Load ¹	lbs	490	1620	2489	1722	717						
				kgs	222	735	1129	781	325						
027	3	D	Rigging Hole Location	inches	12	73	121	181	264	324			168	44	
				mm	314	1845	3073	4601	6717	8218			4259	1122	
			Point Load ¹	lbs	808	570	1411	3527	1214	607					
				kgs	366	259	640	1600	551	275					
027	5	E	Rigging Hole Location	inches	12	73	121	181	264	324			168	44	
				mm	314	1845	3073	4601	6717	8218			4274	1122	
			Point Load ¹	lbs	803	587	1493	3734	1252	626					
				kgs	364	266	677	1694	568	284					
027	8	E	Rigging Hole Location	inches	12	73	121	181	243	347			178	44	
				mm	314	1845	3073	4601	6169	8825			4525	1122	
			Point Load ¹	lbs	542	1407	1099	2747	2054	1027					
				kgs	246	638	498	1246	932	466					
029	5	E	Rigging Hole Location	inches	12	73	179	290	347				177	44	
				mm	314	1845	4551	7358	8825				4495	1122	
			Point Load ¹	lbs	434	1937	4698	1566	583						
				kgs	197	879	2131	710	264						
030	3	C	Rigging Hole Location	inches	12	73	161	254	347				168	44	
				mm	314	1845	4092	6443	8825				4256	1122	
			Point Load ¹	lbs	747	1784	3464	1785	893						
				kgs	339	809	1571	810	405						

NOTE: Weights and approximate center of gravity location shown for base unit. Any options selected may add weight to the unit and affect the center of gravity. Locate the center of gravity through trial lifts to account for possible variations in unit configuration. Contact your nearest Johnson Controls Sales Office for weight data.

¹ Microchannel condenser coils only

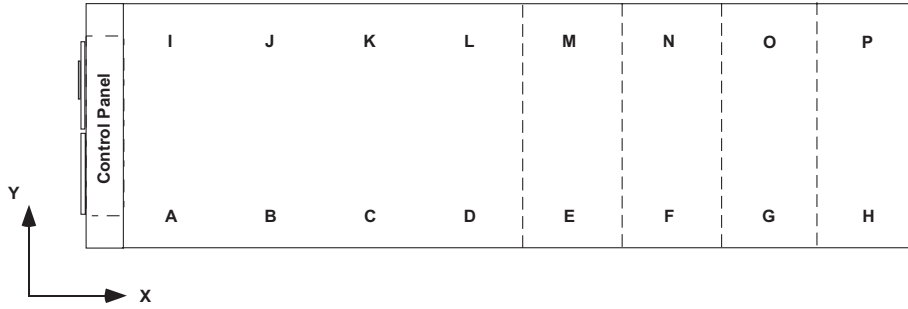

TABLE 1 - UNIT RIGGING (CONT'D)

YVAA MODEL			DESCRIPTION	UNITS	RIGGING HOLES								APPOX. CENTER OF GRAVITY ¹	
FRAME	COND	EVAP			A	B	C	D	E	F	G	H	X (IN)	Y (IN)
030	5	C	Rigging Hole Location	inches	12	73	161	254	306	391			180	44
				mm	314	1845	4092	6443	7763	9941			4566	1122
			Point Load ¹	lbs	559	2024	3021	2164	302	752				
kgs	253	918		1370	981	137	341							
030	8	E	Rigging Hole Location	inches	12	73	121	179	243	296	391		204	44
				mm	314	1845	3072	4549	6169	7508	9942		5172	1122
			Point Load ¹	lbs	1113	323	2182	2182	1309	1505	753			
kgs	505	147		990	990	594	683	341						
031	8	E	Rigging Hole Location	inches	12	73	121	179	243	353	435		210	44
				mm	314	1845	3072	4549	6169	8962	11059		5341	1122
			Point Load ¹	lbs	1028	575	2009	2009	2022	1580	527			
kgs	466	261		911	911	917	717	239						
032	3	E	Rigging Hole Location	inches	12	73	121	181	243	347			177	44
				mm	314	1845	3073	4601	6169	8825			4504	1122
			Point Load ¹	lbs	701	1261	1250	3125	1960	980				
kgs	318	572		567	1417	889	445							
033	3	C	Rigging Hole Location	inches	12	73	163	254	306	391			180	44
				mm	314	1845	4144	6443	7765	9942			4563	1122
			Point Load ¹	lbs	550	2052	3327	2098	333	752				
kgs	250	931		3327	952	151	341							
034	3	E	Rigging Hole Location	inches	12	73	121	181	243	296	391		204	44
				mm	314	1845	3073	4602	6170	7511	9942		5172	1122
			Point Load ¹	lbs	1087	408	2224	2224	1456	1505	753			
kgs	493	185		1009	1009	660	683	341						
034	5	E	Rigging Hole Location	inches	12	73	121	181	243	353	435		210	44
				mm	314	1845	3073	4602	6170	8961	11059		5338	1122
			Point Load ¹	lbs	1002	659	2048	2048	2173	1580	527			
kgs	455	299		929	929	986	717	239						
036	8	J	Rigging Hole Location	inches	12	73	181	238	302	392	434	501	208	46
				mm	314	1845	4602	6039	7662	9957	11024	12725	5283	1168
			Point Load ¹	lbs	142	2884	4376	929	1857	697	310	520		
kgs	64	1308		1985	421	842	316	141	236					
037	3	F	Rigging Hole Location	inches	12	73	181	238	302	435			210	49
				mm	314	1845	4602	6039	7662	11059			5334	1245
			Point Load ¹	lbs	396	2152	4507	396	2142	881				
kgs	179	976		2044	179	972	400							
037	5	J	Rigging Hole Location	inches	12	73	181	238	302	435			198	46
				mm	314	1845	4602	6039	7662	11059			5029	1168
			Point Load ¹	lbs	268	2654	4794	288	2430	881				
kgs	131	1024		2175	131	1102	400							

NOTE: Weights and approximate center of gravity location shown for base unit. Any options selected may add weight to the unit and affect the center of gravity. Locate the center of gravity through trial lifts to account for possible variations in unit configuration. Contact your nearest Johnson Controls Sales Office for weight data.

¹ Microchannel condenser coils only

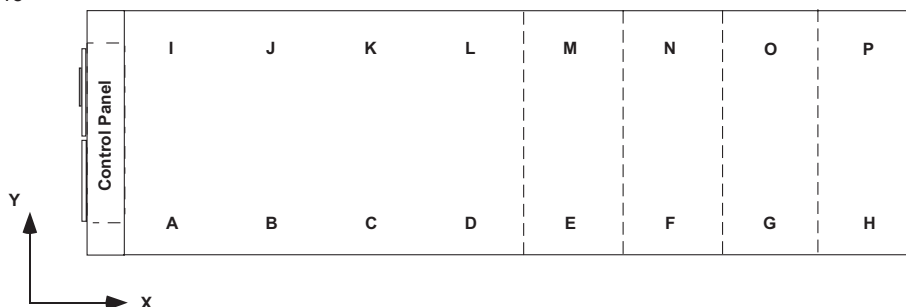

TABLE 1 - UNIT RIGGING (CONT'D)

YVAA MODEL			DESCRIPTION	UNITS	RIGGING HOLES								APPOX. CENTER OF GRAVITY ¹	
FRAME	COND	EVAP			I	J	K	L	M	N	O	P	X (IN)	Y (IN)
030	5	C	Rigging Hole Location	inches	12	73	161	254	306	391			180	44
				mm	314	1845	4092	6443	7763	9941			4566	1122
			Point Load ¹	lbs	411	2226	2990	2374	299	752				
kgs	187	1010		1356	1077	136	341							
030	8	E	Rigging Hole Location	inches	12	73	121	179	243	296	391		204	44
				mm	314	1845	3072	4549	6169	7508	9942		5172	1122
			Point Load ¹	lbs	1073	398	2162	2162	1547	1505	753			
kgs	487	180		981	981	702	683	341						
031	8	E	Rigging Hole Location	inches	12	73	121	179	243	353	435		210	44
				mm	314	1845	3072	4549	6169	8962	11059		5341	1122
			Point Load ¹	lbs	988	650	1988	1988	2259	1580	527			
kgs	448	295		902	902	1025	717	239						
032	3	E	Rigging Hole Location	inches	12	73	121	181	243	347			177	44
				mm	314	1845	3073	4601	6169	347			4504	1122
			Point Load ¹	lbs	604	1370	1204	3010	2060	1030				
kgs	274	622		546	1365	934	467							
033	3	C	Rigging Hole Location	inches	12	73	163	254	306	391			180	44
				mm	314	1845	4144	6443	7765	9942			4563	1122
			Point Load ¹	lbs	373	2354	2951	2387	295	752				
kgs	169	1068		1338	1083	134	341							
034	3	E	Rigging Hole Location	inches	12	73	121	181	243	296	391		204	44
				mm	314	1845	3073	4602	6170	7511	9942		5172	1122
			Point Load ¹	lbs	1038	514	2135	2135	1578	1505	753			
kgs	471	233		968	968	716	683	341						
034	5	E	Rigging Hole Location	inches	12	73	121	181	243	353	435		210	44
				mm	314	1845	3073	4602	6170	8961	11059		5338	1122
			Point Load ¹	lbs	953	765	1959	1959	2295	1580	527			
kgs	432	347		889	889	1041	717	239						
036	8	J	Rigging Hole Location	inches	12	73	181	238	302	392	434	501	208	46
				mm	314	1845	4602	6039	7662	9957	11024	12725	5283	1168
			Point Load ¹	lbs	130	2825	5741	935	1871	827	312	475		
kgs	59	1281		2604	424	849	375	141	215					
037	3	F	Rigging Hole Location	inches	12	73	181	238	302	435			210	49
				mm	314	1845	4602	6039	7662	11059			5334	1245
			Point Load ¹	lbs	368	2116	5853	368	2287	881				
kgs	167	960		2655	167	1037	400							
037	5	J	Rigging Hole Location	inches	12	73	181	238	302	435			198	46
				mm	314	1845	4602	6039	7662	11059			5029	1168
			Point Load ¹	lbs	268	2613	6131	268	2574	881				
kgs	122	1185		2781	122	1168	400							

NOTE: Weights and approximate center of gravity location shown for base unit. Any options selected may add weight to the unit and affect the center of gravity. Locate the center of gravity through trial lifts to account for possible variations in unit configuration. Contact your nearest Johnson Controls Sales Office for weight data.
¹ Microchannel condenser coils only

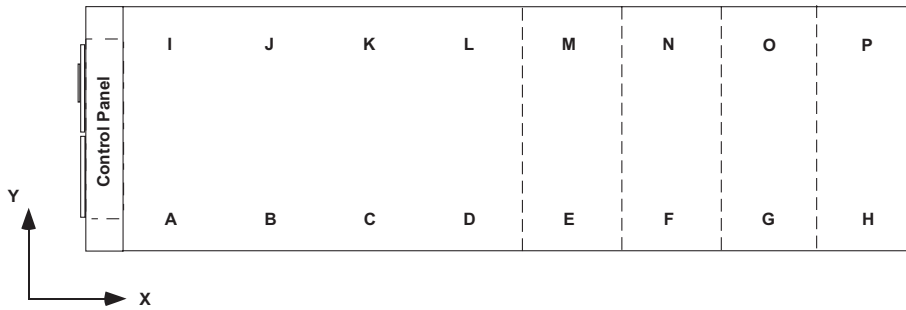

TABLE 1 - UNIT RIGGING (CONT'D)

YVAA MODEL			DESCRIPTION	UNITS	RIGGING HOLES								APPOX. CENTER OF GRAVITY ¹	
FRAME	COND	EVAP			A	B	C	D	E	F	G	H	X (IN)	Y (IN)
039	8	J	Rigging Hole Location	inches	12	73	181	238	302	435	478	545	218	46
				mm	314	1845	4602	6039	7358	11059	12135	13835	5537	1168
			Point Load ¹	lbs	101	2865	4576	1068	2019	72	169	1517		
				kgs	47	1300	2076	484	916	33	77	688		
041	3	H	Rigging Hole Location	inches	12	73	181	238	302	435			219	46
				mm	314	1845	4601	6039	7662	11059			5663	1168
			Point Load ¹	lbs	423	2025	4375	423	1910	881				
				kgs	192	918	1984	192	867	400				
042	5	H	Rigging Hole Location	inches	12	73	181	238	302	435	478	545	222	46
				mm	314	1845	4602	6039	7358	11059	12135	13835	5639	1169
			Point Load ¹	lbs	85	2831	3122	1273	1707	74	172	1534		
				kgs	39	1284	1416	577	774	34	78	696		
042	8	J	Rigging Hole Location	inches	12	73	181	238	302	435	494	572	227	46
				mm	314	1845	4602	6039	7358	11059	12546	14541	5766	1168
			Point Load ¹	lbs	204	2793	5125	71	2514	454	1056	551		
				kgs	93	1267	2325	32	1140	206	479	250		
044	3	G	Rigging Hole Location	inches	12	73	181	238	290	435	478	545	227	46
				mm	314	1845	4602	6039	7662	11059	12135	13835	5766	1168
			Point Load ¹	lbs	189	2952	5346	608	2066	77	176	1557		
				kgs	89	1339	2425	276	937	35	80	706		
047	5	J	Rigging Hole Location	inches	12	73	181	238	290	435	494	572	234	46
				mm	314	1845	4602	6039	7358	11059	12546	14541	5944	1168
			Point Load ¹	lbs	335	3102	5541	318	2792	518	1055	551		
				kgs	152	1407	2513	144	1266	235	479	250		
048	3	G	Rigging Hole Location	inches	12	73	181	238	290	435	494	572	234	46
				mm	314	1845	4602	6039	7358	11059	12546	14529	5944	1168
			Point Load ¹	lbs	338	2564	5914	104	2308	518	1055	551		
				kgs	153	1163	2683	47	1047	235	479	250		
050	0	J	Rigging Hole Location	inches	12	73	181	238	290	435		572	204	46
				mm	305	1854	4597	6045	7366	11049		14529	5182	1168
			Point Load ¹	lbs	142	3568	4804	961	2572	937		551		
				kgs	64	1618	2179	436	1167	425		250		
052	3	J	Rigging Hole Location	inches	12	73	181	238	290	435	494	572	234	46
				mm	305	1854	4597	6045	7366	11049	12548	14529	5944	1168
			Point Load ¹	lbs	335	3102	5541	318	2792	518	1055	551		
				kgs	152	1407	2513	144	1266	235	478	250		

NOTE: Weights and approximate center of gravity location shown for base unit. Any options selected may add weight to the unit and affect the center of gravity. Locate the center of gravity through trial lifts to account for possible variations in unit configuration. Contact your nearest Johnson Controls Sales Office for weight data.

¹ Microchannel condenser coils only

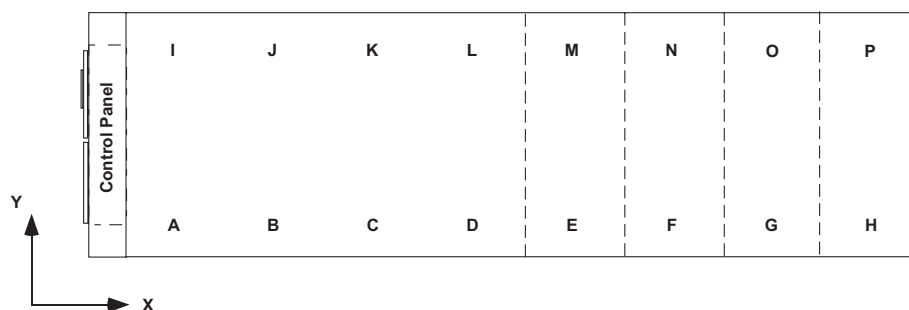

TABLE 1 - UNIT RIGGING (CONT'D)

YVAA MODEL			DESCRIPTION	UNITS	RIGGING HOLES								APPOX. CENTER OF GRAVITY ¹	
FRAME	COND	EVAP			I	J	K	L	M	N	O	P	X (IN)	Y (IN)
039	8	J	Rigging Hole Location	inches	12	73	181	238	302	435	478	545	218	46
				mm	314	1845	4602	6039	7358	11059	12135	13835	5537	1168
			Point Load ¹	lbs	108	2759	5815	980	2153	70	167	1504		
				kgs	49	1251	2638	445	977	32	76	682		
041	3	H	Rigging Hole Location	inches	12	73	181	238	302	435			219	46
				mm	314	1845	4601	6039	7662	11059			5663	1168
			Point Load ¹	lbs	406	1977	5529	406	2008	881				
				kgs	184	897	2508	184	911	400				
042	5	H	Rigging Hole Location	inches	12	73	181	238	302	435	478	545	222	46
				mm	314	1845	4602	6039	7358	11059	12135	13835	5639	1169
			Point Load ¹	lbs	92	2725	4362	1185	1841	72	170	1520		
				kgs	42	1236	1979	538	835	33	77	689		
042	8	J	Rigging Hole Location	inches	12	73	181	238	302	435	494	572	227	46
				mm	314	1845	4602	6039	7358	11059	12546	14541	5766	1168
			Point Load ¹	lbs	198	2927	5792	323	2635	454	1056	551		
				kgs	90	1328	2627	147	1195	206	479	250		
044	3	G	Rigging Hole Location	inches	12	73	181	238	290	435	478	545	227	46
				mm	314	1845	4602	6039	7358	11059	12135	13835	5766	1168
			Point Load ¹	lbs	119	3024	5101	796	2117	78	176	1561		
				kgs	54	1372	2314	361	960	35	80	708		
047	5	J	Rigging Hole Location	inches	12	73	181	238	290	435	494	572	234	46
				mm	314	1845	4602	6039	7358	11059	12546	14541	5944	1168
			Point Load ¹	lbs	263	3176	5295	496	2858	518	1055	551		
				kgs	119	1441	2402	225	1296	235	479	250		
048	3	G	Rigging Hole Location	inches	12	73	181	238	290	435			234	46
				mm	305	1854	4597	6045	7366	11049			5944	1168
			Point Load ¹	lbs	270	2630	5677	282	2367	518	1055	551		
				kgs	122	1193	2575	128	1074	235	479	250		
050	0	J	Rigging Hole Location	inches	12	73	181	238	290	435			234	46
				mm	305	1854	4597	6045	7366	11049			5944	1168
			Point Load ¹	lbs	263	3176	5295	496	2858	518				
				kgs	119	1441	2402	225	1296	235				
052	3	J	Rigging Hole Location	inches	12	73	181	238	290	435	494	572	234	46
				mm	305	1854	4597	6045	7366	11049	12548	14529	5944	1168
			Point Load ¹	lbs	263	3176	5295	496	2858	518	1055	551		
				kgs	119	1441	2402	225	1296	235	478	250		

NOTE: Weights and approximate center of gravity location shown for base unit. Any options selected may add weight to the unit and affect the center of gravity. Locate the center of gravity through trial lifts to account for possible variations in unit configuration. Contact your nearest Johnson Controls Sales Office for weight data.
¹ Microchannel condenser coils only

THIS PAGE INTENTIONALLY LEFT BLANK

SECTION 4 - INSTALLATION

LOCATION REQUIREMENTS

For optimum performance and trouble-free service, it is essential that the installation site meet the location and space requirements for the model being installed.

It is important to ensure that the minimum service access space is maintained for cleaning and maintenance purposes.

OUTDOOR INSTALLATIONS

The units are designed for outdoor installation and can be installed at ground level on a suitable flat level foundation easily capable of supporting the weight of the unit, or on a suitable rooftop location. In both cases an adequate supply of air is required. Avoid locations where the sound output and air discharge from the unit may be objectionable.

The location should be selected for minimum sun exposure and away from boiler flues and other sources of airborne chemicals that could attack the condenser coils and steel parts of the unit.

If located in an area accessible to unauthorized persons, steps must be taken to prevent access to the unit by means of a protective fence. This will help to prevent the possibility of vandalism, accidental damage, or possible harm caused by unauthorized removal of protective guards or opening panels to expose rotating or high voltage components.

For ground level locations, the unit must be installed on a suitable flat and level concrete base that extends to fully support the two side channels of the unit base frame. A one-piece concrete slab, with footings extending below the frost line is recommended. To avoid noise and vibration transmission, the unit should not be secured to the building foundation.

On rooftop locations, choose a place with adequate structural strength to safely support the entire operating weight of the unit and service personnel. The unit can be mounted on a concrete slab, similar to ground floor locations, or on steel channels of suitable strength. The channels should be spaced with the same centers as the unit side and front base rails. This will allow vibration isolators to be fitted if required. Isolators are recommended for rooftop locations.

Mounting holes (5/8") are provided in the base rails for bolting the unit to its foundation. Refer to *Table 7 on Page 70* for location of the mounting holes.

Any ductwork or attenuators fitted to the unit must not have a total static pressure resistance, at full unit airflow, exceeding the capability of the fans installed in the unit.

The condenser fans are propeller-type and are not recommended for use with ductwork, filters or other impediments to airflow in the condenser air stream.

When it is desirable to surround the unit(s) in addition to whatever optional louver package is selected, it is recommended that the screening be able to pass the required chiller CFM without exceeding 0.1" w.g. (24.9084 pa) external static pressure.

Protection against corrosive environments is available by ordering the units with cured epoxy-coating on the microchannel condenser coil. Epoxy-coated coils should be used with any units being installed at the seashore where salt spray/mist may hit the units, or where acid rain is prevalent.

On installations where winter operation is intended and snow accumulations are expected, additional elevation must be provided to insure normal condenser air flow.

Avoid locations near windows or structures where normal operating sounds may be objectionable.

LOCATION CLEARANCES

Adequate clearances around the unit(s) are required for the unrestricted airflow for the air-cooled condenser coils and to prevent re-circulation of warm discharge air back onto the coils. If clearances given are not maintained, airflow restriction or re-circulation will cause a loss of unit performance, an increase in power consumption, and may cause the unit to malfunction. Consideration should also be given to the possibility of down drafts, caused by adjacent buildings, which may cause re-circulation or uneven unit airflow.

For locations where significant cross winds are expected, such as exposed roof tops, an enclosure of solid or louver type is recommended to prevent wind turbulence interfering with the unit airflow.

When units are installed in an enclosure, the enclosure height should not exceed the height of the unit on more than one side. If the enclosure is of louvered construction, the same requirement of static pressure loss applies as for ducts and attenuators stated above.

Recommended Minimum Clearances

Recommended clearances for the YVAA units are:

- Side to wall – 6' (1.8 m)
- Rear to wall – 6' (1.8 m)
- Control panel end to wall – 4' (1.2 m)
- Top – no obstructions whatsoever
- Distance between adjacent units – 10' (3 m)

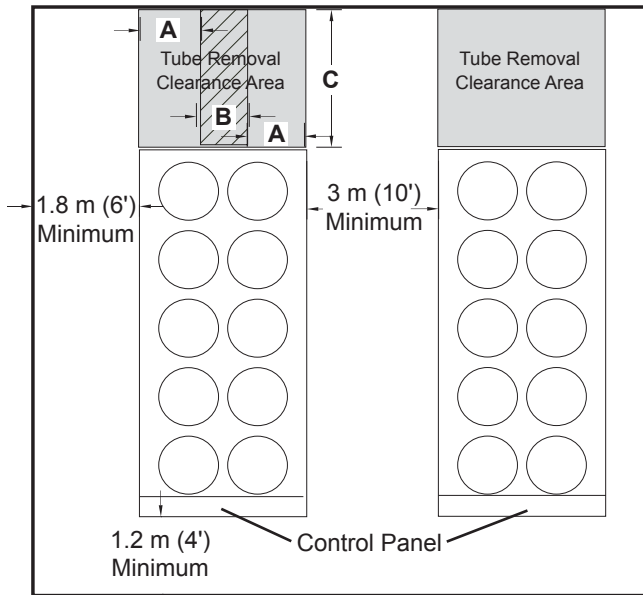

FIGURE 4 - ACCEPTABLE MINIMUM CLEARANCES AROUND/BETWEEN UNIT(S)



Clearance dimensions provided in Figure 5 are necessary to maintain good airflow and ensure correct unit operation. It is also necessary to consider access requirements for safe operation and maintenance of the unit and power and control panels. Local health and safety regulations, or practical considerations for service replacement of large components, may require larger clearances than those recommended.

TABLE 2 - MINIMUM EVAPORATOR TUBE REMOVAL CLEARANCE

MODEL YVAA			TUBE REMOVAL CLEARANCE DIMENSIONS					
			A		B		C	
FRAME	COND	EVAP	IN.	MM	IN.	MM	IN.	MM
015	3	B	26	663	36	914	132	3353
016	5	B	26	663	36	914	132	3353
017	8	C	26	663	36	914	156	3962
018	3	A	26	663	36	914	144	3658
019	5	A	26	663	36	914	144	3658
019	8	B	26	663	36	914	144	3658
020	0	C	26	663	36	914	156	3962
021	3	A	26	663	36	914	156	3962
021	5	C	26	663	36	914	156	3962
021	8	C	26	663	36	914	156	3962
023	3	B	26	663	36	914	132	3353
024	5	C	26	663	36	914	156	3962
024	8	C	26	663	36	914	156	3962
026	3	B	26	663	36	914	132	3353
027	3	D	26	663	36	914	192	4877
027	5	E	26	663	36	914	192	4877
027	8	E	26	663	36	914	192	4877
029	5	E	26	663	36	914	192	4877
030	3	C	26	663	36	914	156	3962
030	5	E	26	663	36	914	156	3962
030	8	E	26	663	36	914	156	3962
031	8	E	26	663	36	914	192	4877
032	3	E	26	663	36	914	192	4877
033	3	C	26	663	36	914	156	3962
034	3	E	26	663	36	914	192	4877
034	5	E	26	663	36	914	192	4877
036	8	J	26	663	36	914	192	4877
037	3	F	26	663	36	914	144	3658
037	5	J	26	663	36	914	192	4877
039	8	J	26	663	36	914	192	4877
041	3	H	26	663	36	914	192	4877
042	5	H	26	663	36	914	144	3658
042	8	J	26	663	36	914	192	4877
044	3	G	26	663	36	914	144	3658
047	5	J	26	663	36	914	192	4877
048	3	G	26	663	36	914	144	3658
050	0	J	26	663	36	914	192	4877
052	3	J	26	663	36	914	192	4877

VIBRATION ISOLATORS

Optional sets of vibration isolators can be supplied loose with each unit.

Using the Isolator tables shipped with the unit in the information pack. Identify each mount and its correct location on the unit.

Installation

Place each mount in its correct position and lower the unit carefully onto the mounts ensuring the mount engages in the mounting holes in the unit base frame.

On adjustable mounts, transfer the unit weight evenly to the springs by turning the mount adjusting nuts (located just below the top plate of the mount) counter-clockwise to raise and clockwise to lower. This should be done two turns at a time until the top plates of all mounts are between 1/4" (6 mm) and 1/2" (12 mm) clear of top of their housing and the unit base is level.

SHIPPING BRACES

The chiller's modular design does not require shipping braces.

CHILLED LIQUID PIPING

General Requirements

The following piping recommendations are intended to ensure satisfactory operation of the unit(s). Failure to follow these recommendations could cause damage to the unit, or loss of performance, and may invalidate the warranty.



The maximum flow rate and pressure drop for the evaporator must not be exceeded at any time. Refer to Section 5 - Technical Data on Page 61 for details.

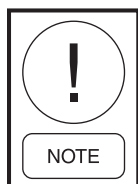

The liquid must enter the evaporator at the inlet connection. The standard inlet connection for the evaporator is opposite the control panel end of the evaporator.

A flow switch must be installed in the customer piping at the outlet of the evaporator and wired back to the control panel using shielded cable.

There should be a straight run of piping of at least 5 pipe diameters on either side. The flow switch should be wired to Terminals 2 and 13 on the 1TB terminal block. A flow switch is required to prevent damage to the evaporator caused by the unit operating without adequate liquid flow.

The flow switch used must have gold plated contacts for low voltage/current operation. Paddle type flow switches suitable for 10 bar (150 PSIG) working pressure and having a 1" N.P.T. connection can be obtained from Johnson Controls as an accessory for the unit. Alternatively, a

differential pressure switch fitted across an orifice plate may be used, preferably of the high/low limit type.

The chilled liquid pump(s) installed in the piping system(s) should discharge directly into the unit evaporator section of the system. The pump(s) may be controlled by the chiller controls or external to the unit.

Pipework and fittings must be separately supported to prevent any loading on the evaporator. Flexible connections are recommended which will also minimize transmission of vibrations to the building. Flexible connections must be used if the unit is mounted on anti-vibration mounts, as some movement of the unit can be expected in normal operation.

Piping and fittings immediately next to the evaporator should be readily de-mountable to enable cleaning before operation, and to facilitate visual inspection of the exchanger nozzles.



The evaporator must be protected by a strainer, preferably of 40 mesh, fitted as close as possible to the liquid inlet connection, and provided with a means of local isolation.

The evaporator must not be exposed to flushing velocities or debris released during flushing. It is recommended that a suitably sized bypass and valve arrangement is installed to allow flushing of the piping system. The bypass can be used during maintenance to isolate the heat exchanger without disrupting flow to other units.

Thermometer and pressure gauge connections should be provided on the inlet and outlet connections of each evaporator. Gauges and thermometers are not provided with the unit and are to be furnished by others.

Drain and air vent connections should be provided at all low and high points in the piping to permit drainage of the system and to vent any air in the pipes.

Liquid system lines at risk of freezing, due to low ambient temperatures should be protected using insulation and heater tape and/or a suitable glycol solution. The liquid pump(s) may also be used to ensure liquid is circulated when the ambient temperature approaches freezing point.

Insulation should also be installed around the evaporator nozzles. Heater tape of 21 Watts per meter under the insulation is recommended, supplied independently and controlled by an ambient temperature thermostat set to switch ON at approximately 2.2°C (4°F), above the freezing temperature of the chilled liquid.

Evaporator heater mats are installed under the insulation, and are powered from the chiller's control panel. In sub-freezing conditions, unless the evaporator has been drained or an appropriate water-to-glycol concentration is maintained, high voltage power to the chiller must be kept on to ensure the heater mats assist in evaporator freeze protection. If there is a potential for power loss, Johnson Controls recommends that the evaporator is drained or that water in the chilled water circuit be replaced with an appropriate water-to-glycol concentration.



Any debris left in the water piping between the strainer and evaporator could cause serious damage to the tubes in the evaporator and must be avoided. Be sure the piping is clean before connecting it to the evaporator. Keep evaporator nozzles and chilled liquid piping capped prior to installation to assure construction debris is not allowed to enter.



The installer/user must also ensure that the quality of the water in circulation is adequate, without any dissolved gases, which can cause oxidation of steel or copper parts within the evaporator.

WATER TREATMENT

The unit performance provided in the Design Guide is based on a fouling factor of 0.018m²/hr °C/kW (0.0001 ft²hr°F/Btu). Dirt, scale, grease and certain types of water treatment will adversely affect the heat exchanger surfaces and therefore the unit performance. Foreign matter in the water system(s) can increase the heat exchanger pressure drop, reducing the flow rate and causing potential damage to the heat exchanger tubes.

Aerated, brackish or salt water is not recommended for use in the water system(s). Johnson Controls recommends that a water treatment specialist should be consulted to determine whether the proposed water composition will adversely affect the evaporator materials of carbon steel and copper. The pH value of the water flowing through the evaporator must be kept in a range between 7 and 8.5.

PIPEWORK ARRANGEMENT

The following is a suggested piping arrangement for single unit installations.

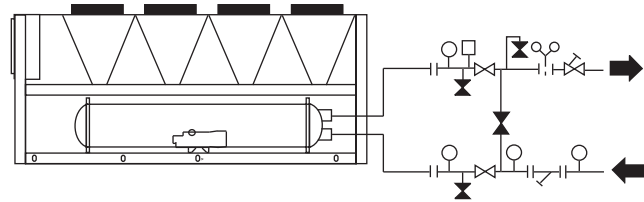

- ⊗ - Isolating Valve - Normally Open
- ⊗ (with diagonal line) - Isolating Valve - Normally Closed
- ⊗ (with triangle) - Flow Regulating Valve
- ⊗ (with circle) - Flow Measurement Device
- ⊗ (with vertical line) - Strainer
- ⊗ (with circle) - Pressure Tapping
- ⊗ (with square) - Flow Switch
- ⊗ (with horizontal line) - Flanged Connection
- - Pipework

LD15151

FIGURE 5 - PIPEWORK ARRANGEMENT

MINIMUM WATER VOLUME

It is good practice to include as much water volume as possible in a chilled water loop. This increases the thermal mass and “Flywheel” effect within the system (i.e. the more; the better) which in turn promotes stable water temperature control and increases reliability by reducing compressor cycling.

For air conditioning applications, a minimum of 3 gallons/ton is required. It is preferred that the gallon/ton ratio be within the 5 to 8 range. For process applications, a minimum of 6 gallons/ton ratio is required with preference towards a range of 7 to 11. Install a tank or increase pipe sizes to provide sufficient water volume.

LEAVING WATER TEMPERATURE OUT OF RANGE

The YVAA chiller line has a maximum leaving water temperature of 15.6°C (60°F). Where process applications require a chilled water temperature higher than what the chiller provides, a simple piping change can remove the problem. By using a mixture of chiller-cooled water and returning process water, the chilled water entering the process can be held at the desired temperature. A tank can also be used to meet high leaving water temperature requirements.

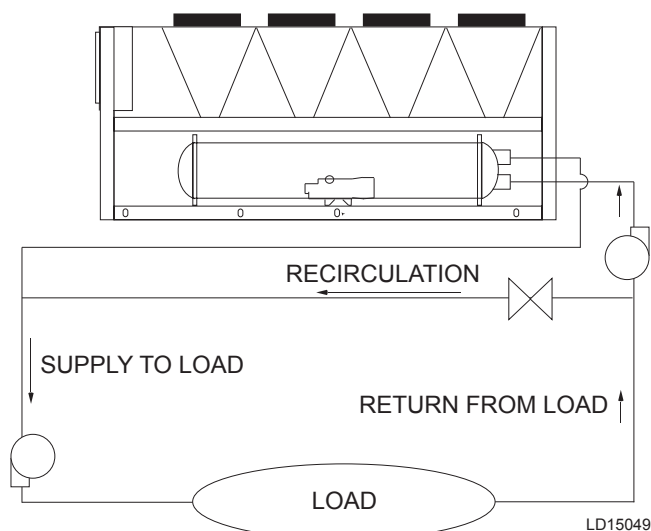

FIGURE 6 - LEAVING WATER TEMPERATURE OUT OF RANGE SUGGESTED LAYOUT

FLOW RATE OUT OF RANGE

Each YVAA evaporator has a minimum and maximum flow rate. Some process applications require a flow rate that is out of range for the evaporator. In those applications, a piping change can remove the problem.

In applications where the required flow rate is less than the evaporator's minimum allowable, the chilled water can be recirculated to the chiller.

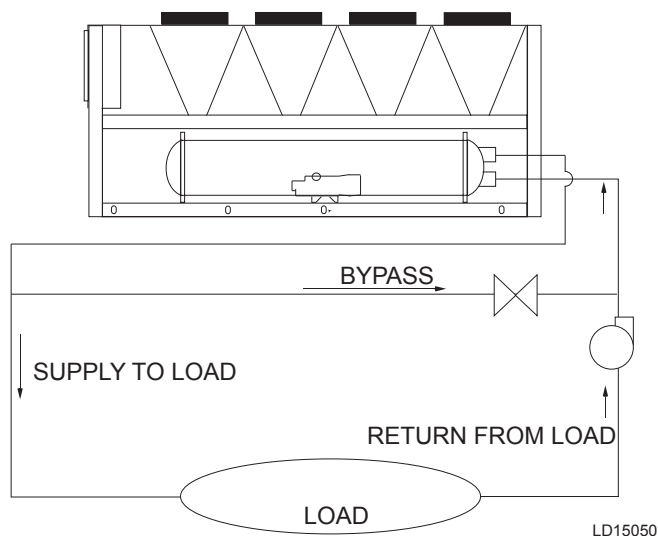

FIGURE 7 - SUGGESTED LAYOUT FOR APPLICATIONS WITH A FLOW RATE LESS THAN THE EVAPORATOR MINIMUM ALLOWABLE FLOW RATE

In applications where the required flow rate is greater than the evaporator's maximum allowable, the chilled water can be recirculated to the load.

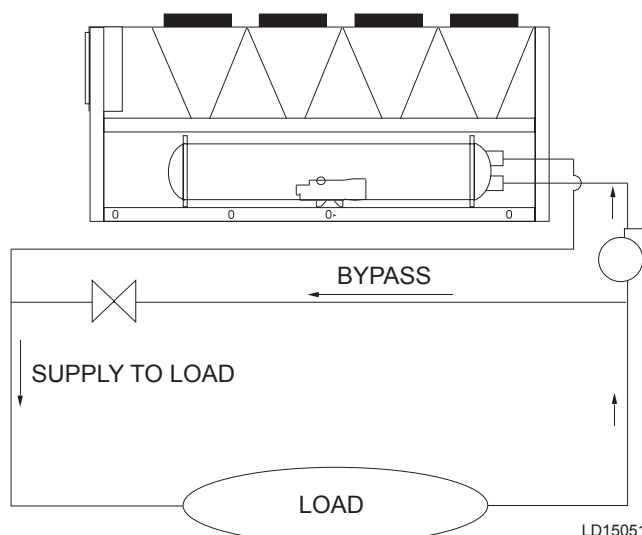

FIGURE 8 - SUGGESTED LAYOUT FOR APPLICATIONS WITH A FLOW RATE GREATER THAN THE EVAPORATOR MAXIMUM ALLOWABLE FLOW RATE

THERMAL STORAGE

Thermal storage is the practice of storing cooling energy during a period of little or no load and/or low energy costs for use during periods of high load and/or energy costs. Conventional cooling systems produce cooling when it is needed which is commonly during times of peak demand. Thermal storage allows generation of cooling capacity to occur during off-peak periods and store that capacity to meet future cooling requirements. Using thermal storage can result in smaller equipment sizes, thereby reducing capital cost, and also can result in significant energy cost savings

The YVAA has special control logic to be able to produce chilled leaving brine temperatures below 4.4°C (40°F) so as to supply a storage tank with chilled liquid during times of low demand. YVAA chillers selected for thermal storage operation can also be selected to efficiently provide chilled fluid at nominal cooling loads.

VARIABLE PRIMARY FLOW

Johnson Controls recommends a maximum 10% per minute flow rate of change, based on design flow, for variable primary flow applications. Provide 8 to 10 gallons per chiller ton (8.6 to 10.8 liter per cooling KW) system water volume. Insufficient system volume and rapid flow changes can cause control problems or can even cause chiller shutdowns. There are many other design issues to evaluate with variable primary flow systems. Consult your Johnson Controls Sales Office for more information about successfully applying YVAA chillers.

CONNECTION TYPES AND SIZES

For connection sizes relevant to individual models refer to *SECTION 5 - TECHNICAL DATA*.

EVAPORATOR CONNECTIONS

Standard chilled liquid connections on evaporators are of the Victaulic Groove type for ASME and PED marked units and Flange type for GB marked units (see *Figure 10 on page 43* for flange dimensions on GB marked vessels).

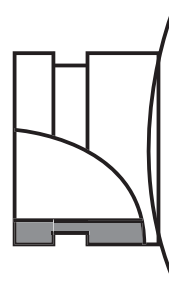

LD10494

FIGURE 9 - VICTAULIC GROOVE**TABLE 3 - EVAPORATOR CONNECTIONS DIMENSIONS**

FRAME	COND.	EVAP.	VICTAULIC CONNECTIONS SIZE	NOMINAL DIAMETER	FLANGE DIMENSIONS (GB ONLY) IN MM*						QTY	
					B	C	D	K	L	D		N
015	3	B	6"	DN150	170.5	27	280	241.5	22	216	8	2
016	5	B	6"	DN150	170.5	27	280	241.5	22	216	8	2
017	8	C	6"	DN150	170.5	27	280	241.5	22	216	8	2
018	3	A	6"	DN150	170.5	27	280	241.5	22	216	8	2
019	5	A	6"	DN150	170.5	27	280	241.5	22	216	8	2
019	8	B	6"	DN150	170.5	27	280	241.5	22	216	8	2
020	0	C	6"	DN150	170.5	27	280	241.5	22	216	8	2
021	3	A	6"	DN150	170.5	27	280	241.5	22	216	8	2
021	5	C	6"	DN150	170.5	27	280	241.5	22	216	8	2
021	8	C	6"	DN150	170.5	27	280	241.5	22	216	8	2
023	3	B	6"	DN150	170.5	27	280	241.5	22	216	8	2
024	5	C	6"	DN150	170.5	27	280	241.5	22	216	8	2
024	8	C	6"	DN150	170.5	27	280	241.5	22	216	8	2
026	3	B	6"	DN150	170.5	27	280	241.5	22	216	8	2
027	3	D	6"	DN150	170.5	27	280	241.5	22	216	8	2
027	5	E	8"	DN200	221.5	27	345	298.5	22	270	8	2
027	8	E	8"	DN200	221.5	27	345	298.5	22	270	8	2
029	5	E	8"	DN200	221.5	27	345	298.5	22	270	8	2
030	3	C	6"	DN150	170.5	27	280	241.5	22	216	8	2
030	5	C	6"	DN150	170.5	27	280	241.5	22	216	8	2
030	8	E	8"	DN200	221.5	27	345	298.5	22	270	8	2
031	8	E	8"	DN200	221.5	27	345	298.5	22	270	8	2
032	3	E	8"	DN200	221.5	27	345	298.5	22	270	8	2
033	3	C	6"	DN150	170.5	27	280	241.5	22	216	8	2
034	3	E	8"	DN200	221.5	27	345	298.5	22	270	8	2
034	5	E	8"	DN200	221.5	27	345	298.5	22	270	8	2
036	8	J	8"	DN200	221.5	27	345	298.5	22	270	8	2
037	3	F	8"	DN200	221.5	27	345	298.5	22	270	8	2
037	5	J	8"	DN200	221.5	27	345	298.5	22	270	8	2
039	8	J	8"	DN200	221.5	27	345	298.5	22	270	8	2
041	3	H	8"	DN200	221.5	27	345	298.5	22	270	8	2
042	5	H	8"	DN200	221.5	27	345	298.5	22	270	8	2
042	8	J	8"	DN200	221.5	27	345	298.5	22	270	8	2
044	3	G	8"	DN200	221.5	27	345	298.5	22	270	8	2
047	5	J	8"	DN200	221.5	27	345	298.5	22	270	8	2
048	3	G	8"	DN200	221.5	27	345	298.5	22	270	8	2
050	0	J	8"	DN200	221.5	27	345	298.5	22	270	8	2
052	3	J	8"	DN200	221.5	27	345	298.5	22	270	8	2

* Reference *Figure 10 on Page 43* for flange dimensions.

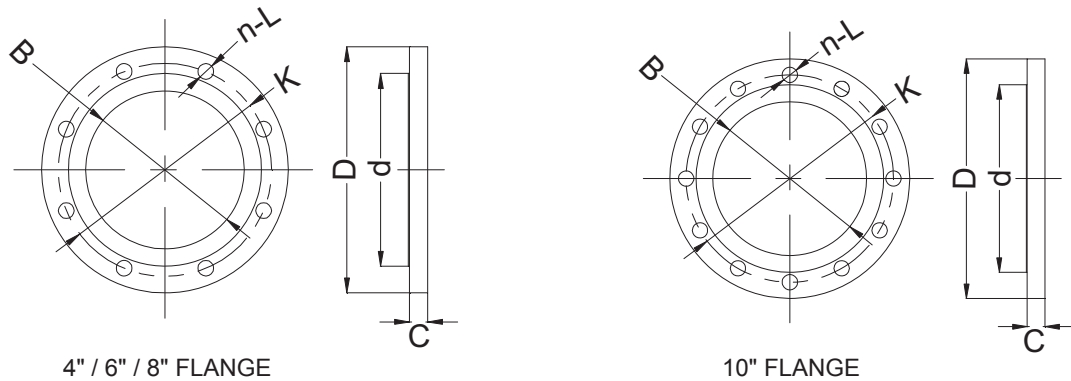

LD16185a

FIGURE 10 - FLANGE FOR GB VESSELS

Option Flanges

One of two types of flanges may be fitted depending on the customer or local pressure vessel code requirements. These are Victaulic-Adapter flanges, normally supplied loose, or weld flanges, which may be supplied loose or ready-fitted. Victaulic-Adapter and weld flange dimensions are to ISO 7005 - NP10.

The size of any piping attached to a relief valve must be of sufficient diameter so as not to cause resistance to the operation of the valve. Unless otherwise specified by local regulations. Internal diameter depends on the length of pipe required and is given by the following formula:

$$D^5 = 1.447 \times L$$

- Where:
- D = minimum pipe internal diameter in cm
- L = length of pipe in meters

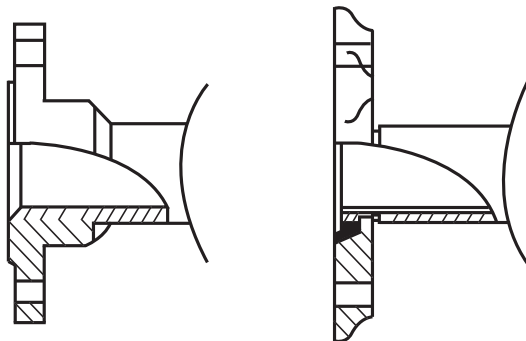

WELD FLANGE VICTAULIC ADAPTER LD10495

FIGURE 11 - FLANGE ATTACHMENT

REFRIGERANT RELIEF VALVE PIPING

The evaporator is protected against internal refrigerant overpressure by refrigerant relief valves. A pressure relief valve is mounted on each of the main refrigerant lines connecting the evaporator to the compressors.

A piece of pipe is fitted to each valve and directed so that when the valve is activated the release of high pressure gas and liquid cannot be a danger or cause injury. For indoor installations (not recommended), pressure relief valves should be piped to the exterior of the building.

ELECTRICAL CONNECTION

The following connection recommendations are intended to ensure safe and satisfactory operation of the unit. Failure to follow these recommendations could cause harm to persons or damage the unit, and may invalidate the warranty.



No additional controls (relays, etc.) should be mounted in the control panel. Power and control wiring not connected to the control panel should not be run through the control panel. If these precautions are not followed it could lead to a risk of electrocution. In addition, electrical noise could cause malfunctions or damage the unit and its controls.



After power wiring connection, do not switch on mains power to the unit. Some internal components are live when the mains are switched on and this must only be done by “Authorized” persons familiar with starting, operating, and troubleshooting this type of equipment.

POWER WIRING

All electrical wiring should be carried out in accordance with local regulations. Route properly sized cables to cable entries on the unit.

In accordance with local codes, NEC codes, U.L. and C.E. standards, it is the responsibility of the user to install over current protection devices between the supply conductors and the power supply terminals on the unit.

To ensure that no eddy currents are set up in the power panel, the cables forming the 3-phase power supply must enter via the same cable entry.



All sources of supply to the unit must be taken via a common point of isolation (not supplied by Johnson Controls).

POWER SUPPLY WIRING

Units require only one 3-phase supply, plus earth.

Connect the 3-phase supplies to the circuit breaker located in the panel (See Electrical Lug Data in *Table 4 on Page 50*).

Connect a suitably sized earth wire to the PE terminal in the panel.

115VAC CONTROL SUPPLY TRANSFORMER

A 3-wire high voltage to 115VAC supply transformer is standard in the chiller. This transformer is mounted in the cabinet and steps down the high voltage supply to 115VAC to be used by the controls, VSD, Feed and Drain Valve Controller, valves, solenoids, heaters, etc.

The high voltage for the transformer primary is taken from the chiller input. Fusing is provided for the transformer.



Removing high voltage power to the chiller will remove the 115VAC supply voltage to the control panel circuitry and the evaporator heater mat. In sub-freezing weather, this could cause serious damage to the chiller due to evaporator freeze-up. Do not remove power unless alternate means are taken to ensure operation of the control panel, evaporator heater mat, and waterbox heaters.

CONTROL WIRING

All control wiring utilizing contact closures to the control panel terminal block is nominal 115VAC and must be run in shielded cable, with the shield grounded at the panel end only, and run in water tight conduit. Run shielded cable separately from mains cable to avoid electrical noise pick-up. Use the control panel cable entry to avoid the power cables.

Voltage free contacts connected to the panel must be suitable for 115VAC10 ma (gold contacts recommended). If the voltage free contacts form part of a relay or contactor, the coil of the device must be suppressed using a standard R/C suppressor. The above precautions must be taken to avoid electrical noise, which could cause a malfunction or damage to the unit and its controls.

VOLTS FREE CONTACTS

Chilled Liquid Pump Starter

Terminals 23 and 24 on 1TB close to start the chilled liquid pump. This contact can be used as a master start/stop for the pump in conjunction with the daily start/stop schedule. Cycle the pumps from the unit panel if the unit will be operational or shut-down during sub-freezing conditions. Refer to the *Evaporator Pump Control on Page 98* for more information on testing the pumps.

Run Contact

Terminals 21 and 22 on 1TB close to indicate that a system is running.

Alarm Contacts

Each system has a single voltage-free contact, which will operate to signal an alarm condition whenever any system locks out, or there is a power failure. To obtain

system alarm signal, connect the alarm circuit to volt free Terminals 25 & 26 (Sys 1), Terminals 27 and 28 (Sys 2) of 1TB.

SYSTEM INPUTS

Flow Switch

A chilled liquid flow switch of suitable type MUST be connected between Terminals 2 and 13 of 1TB to provide protection against loss of liquid flow, which will cause evaporator freeze-up if the chiller is permitted to run. The flow switch circuitry is a 115VACcircuit. Contacts must be rated for low current (5mA). Gold contacts should be used.

Remote Run / Stop

A Remote Run/Stop input is available for each systems. These inputs require a dry contact to start and stop the system. System 1 remote dry contacts are connected between Terminals 2 and 15 of 1TB and System 2 dry contacts are connected between Terminals 2 and 16 of 1TB. If remote start/stop is not utilized, a jumper must be paced across the terminals to allow the system to run. The remote run/stop circuitry is a 115VACcircuit.

Contacts must be rated for low current (5mA). Gold contacts should be used.

Remote Print

Closure of suitable contacts connected to Terminals 2 and 14 of 1TB will cause a hard copy printout of Operating Data/Fault History to be made if an optional printer is connected to the RS-232 port. The remote print circuitry is a 115VACcircuit. Contacts must be rated for low current (5mA). Gold contacts should be used.

Optional Remote Setpoint Offset – Temperature

A voltage signal connected to Terminals 17 and 18 of 1TB will provide a remote offset function of the chilled liquid setpoint, if required.

Optional Remote Setpoint Offset – Current

A voltage signal connected to Terminals 19 and 20 of 1TB will provide a remote setting of current limit setpoint, if required.

Optional Remote Setpoint Offset – Sound Limiting

A voltage signal connected to Terminals 40 and 41 of 1TB will provide remote setting of sound limit setpoint, if required.

POWER SUPPLY WIRING

Single Point Wiring

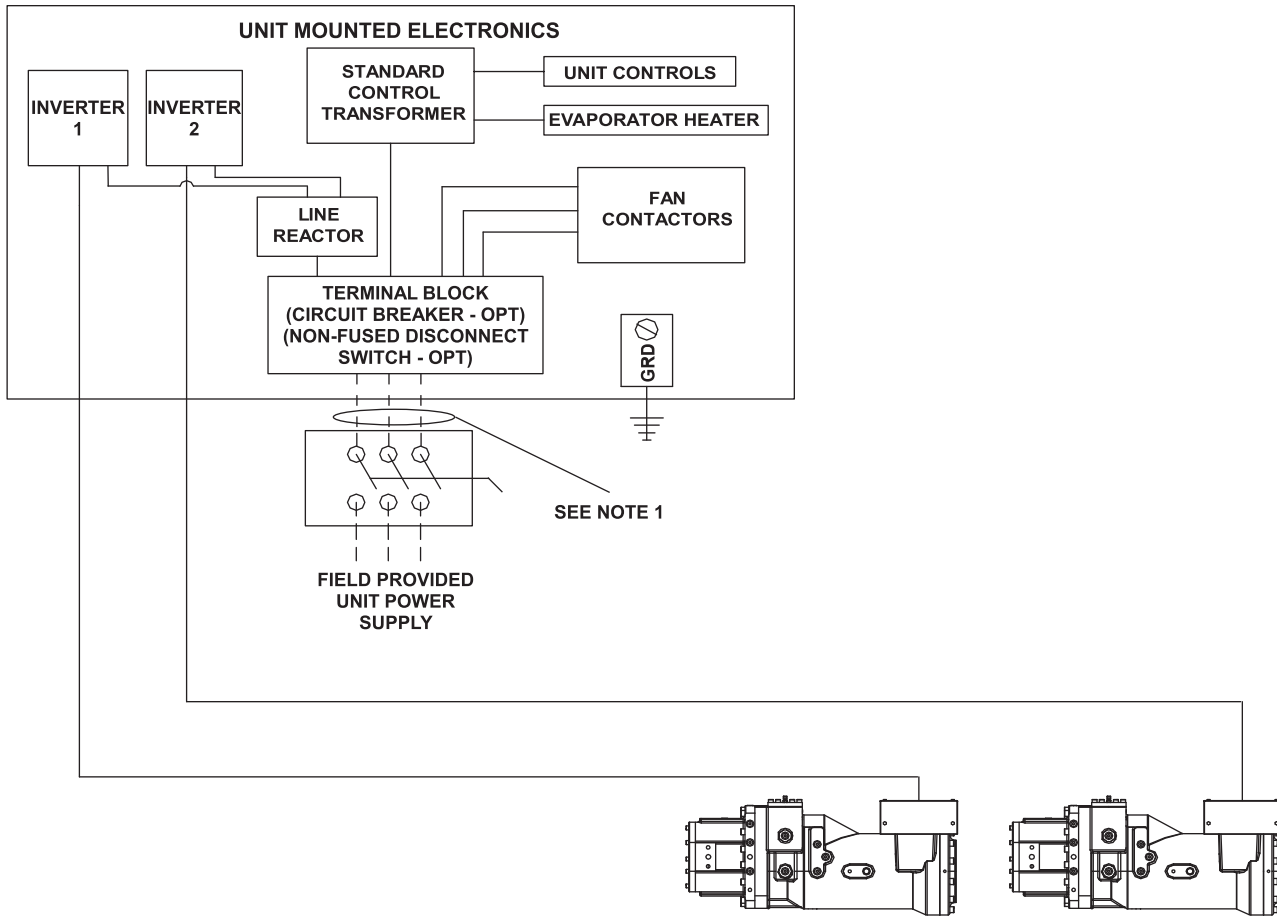

LD18588



Minimum Circuit Ampacity (MCA), Minimum/Maximum Fuse Size and Minimum/Maximum Circuit Breaker size varies on chillers based upon model and options ordered. Consult YorkWorks or the chiller data plate for electrical data on a specific chiller.

Voltage Utilization Range

RATED VOLTAGE	UTILIZATION RANGE
200/60/3	180-220
230/60/3	208-254
380/60/3	342-402
400/60/3	360-440
460/60/3	414-508
575/60/3	520-635
400/50/3	360-440

FIGURE 12 - SINGLE POINT POWER WIRING

Dual Point Wiring

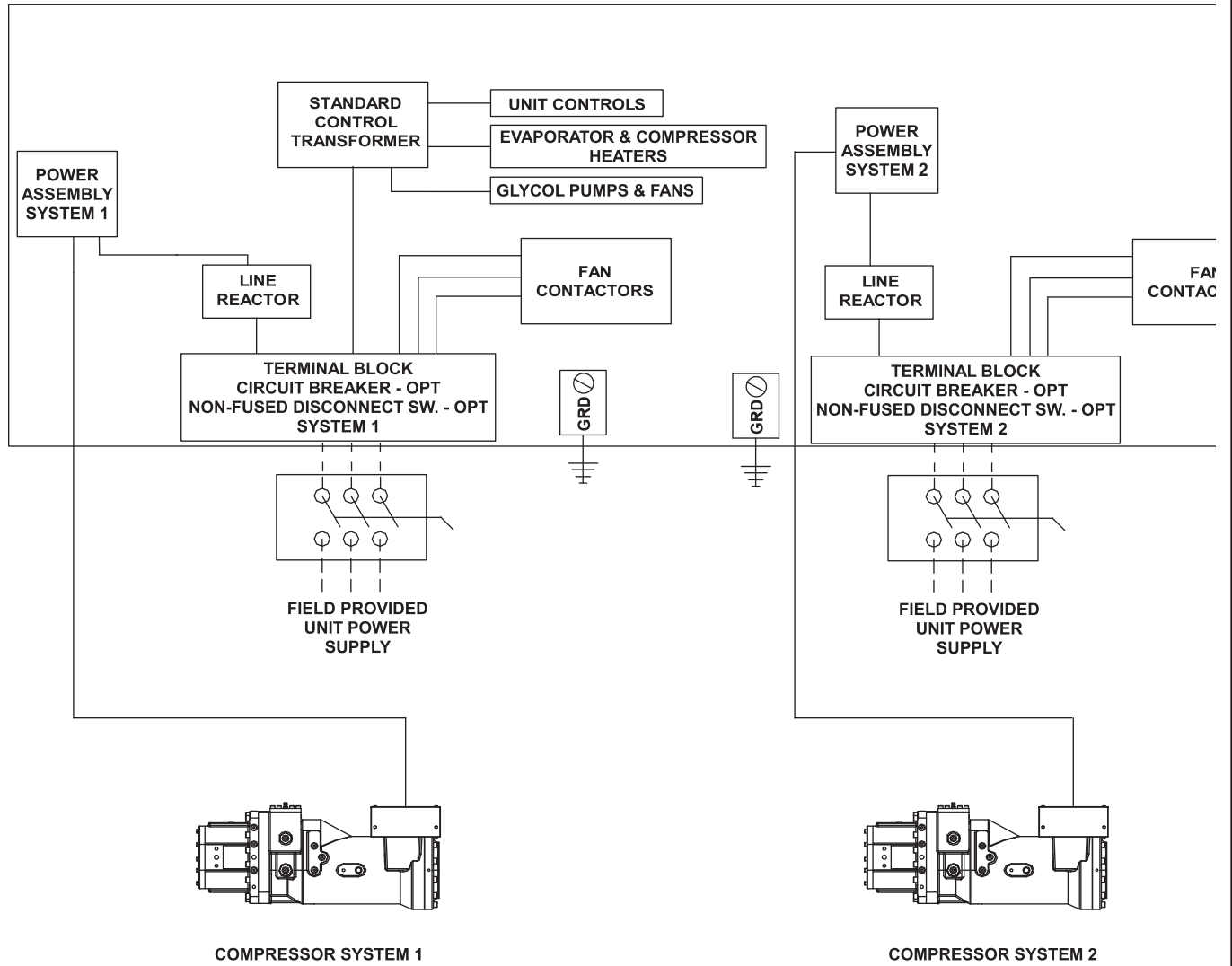

4

LD18589

FIGURE 13 - DUAL POINT POWER WIRING

THIS PAGE INTENTIONALLY LEFT BLANK

CUSTOMER CONTROL WIRING

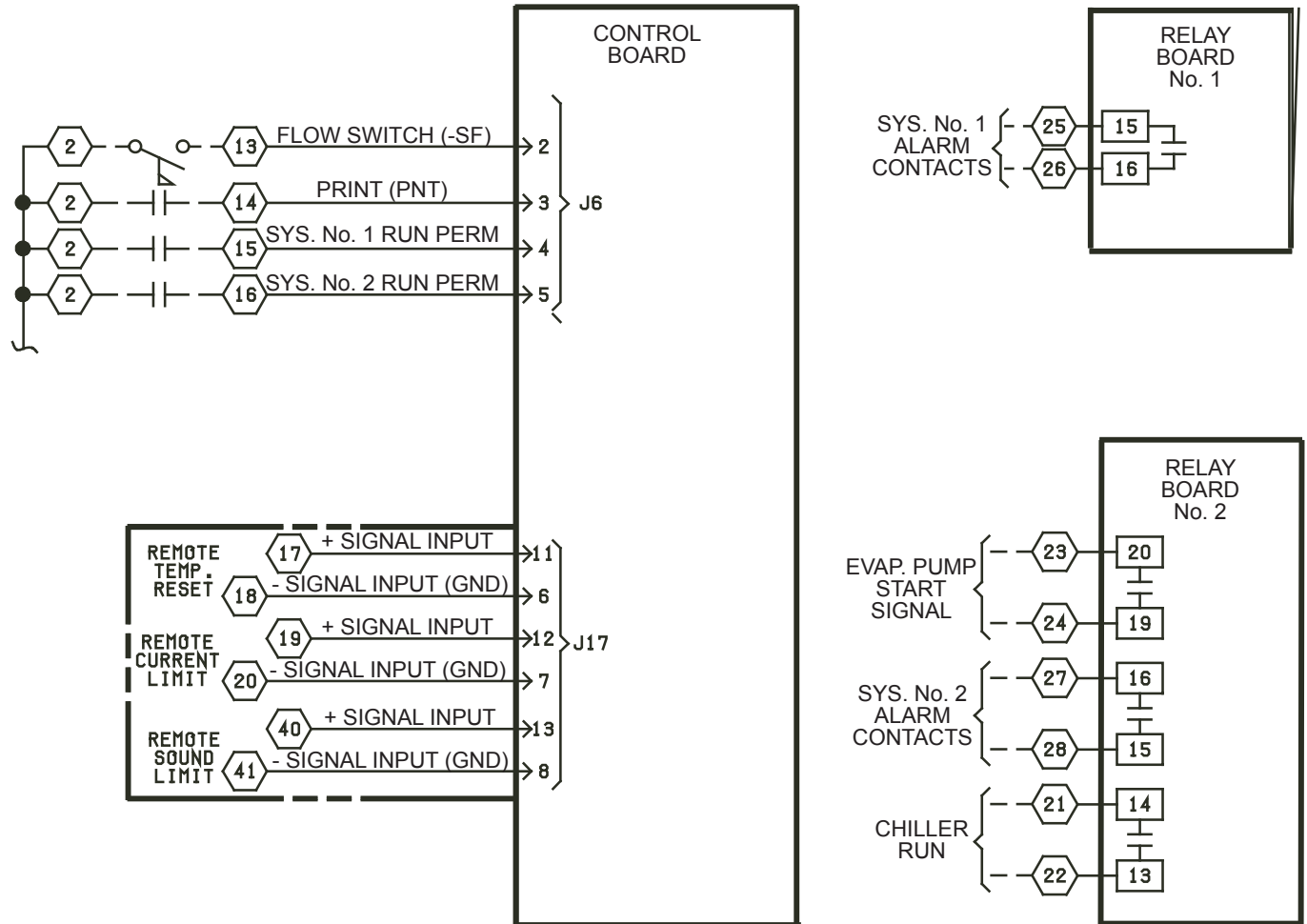

4

LEGEND





-  TERMINAL BLOCK FOR CUSTOMER CONNECTIONS
-  TERMINAL BLOCK FOR YORK CONNECTIONS
-  WIRING AND COMPONENTS BY YORK
-  OPTIONAL EQUIPMENT
-  WIRING AND/OR COMPONENTS BY OTHERS

FIGURE 14 - CUSTOMER CONTROL CONNECTIONS

TABLE 4 - ELECTRICAL LUG DATA

FIELD WIRING LUGS				STANDARD & ULTRA QUIET CONDENSER FANS							
				TERMINAL BLOCK		CIRCUIT BREAKER		NON-FUSED DISCONNECT SWITCH			
YVAA MODEL			INPUT VOLTS	INPUT FREQ	WIRES PER PHASE	LUG WIRE RANGE	WIRES PER PHASE	LUG WIRE RANGE	WIRES PER PHASE	LUG WIRE RANGE	
FRAME	COND	EVAP									
SINGLE POINT WIRING											
015	3	B	200	60	4	#2 - 600 kcmil					
			230	60	4	#2 - 600 kcmil	4	4/0 ~ 500 kcmil			
			380	60	2	#2 - 600 kcmil	2	#2/0 ~ 500 kcmil	2	#2 - 600 kcmil	
			400	50	2	#2 - 600 kcmil	2	#2/0 ~ 500 kcmil	2	#2 - 600 kcmil	
			460	60	2	#2 - 600 kcmil	2	#1 ~ 500 kcmil	2	#2 - 600 kcmil	
			575	60	2	#2 - 600 kcmil	2	#1 ~ 500 kcmil	2	#2 ~ 600 kcmil	
016	5	B	200	60	4	#2 - 600 kcmil					
			230	60	4	#2 - 600 kcmil	4	4/0 ~ 500 kcmil			
			380	60	2	#2 - 600 kcmil	2	#2/0 ~ 500 kcmil	2	#2 - 600 kcmil	
			400	50	2	#2 - 600 kcmil	2	#2/0 ~ 500 kcmil	2	#2 - 600 kcmil	
			460	60	2	#2 - 600 kcmil	2	#1 ~ 500 kcmil	2	#2 - 600 kcmil	
			575	60	2	#2 - 600 kcmil	2	#1 ~ 500 kcmil	2	#2 ~ 600 kcmil	
017	8	C	200	60	4	#2 - 600 kcmil					
			230	60	4	#2 - 600 kcmil	4	4/0 ~ 500 kcmil			
			380	60	2	#2 - 600 kcmil	2	#2/0 ~ 500 kcmil	2	#2 - 600 kcmil	
			400	50	2	#2 - 600 kcmil	2	#2/0 ~ 500 kcmil	2	#2 - 600 kcmil	
			460	60	2	#2 - 600 kcmil	2	#1 ~ 500 kcmil	2	#2 - 600 kcmil	
			575	60	2	#2 - 600 kcmil	2	#1 ~ 500 kcmil	2	#2 ~ 600 kcmil	
018	3	A	200	60	4	#2 - 600 kcmil					
			230	60	4	#2 - 600 kcmil	4	4/0 ~ 500 kcmil			
			380	60	2	#2 - 600 kcmil	2	#1 ~ 500 kcmil	3	#2 ~ 600 kcmil	
			400	50	2	#2 - 600 kcmil	2	#1 ~ 500 kcmil	3	#2 ~ 600 kcmil	
			460	60	2	#2 - 600 kcmil	2	#1 ~ 500 kcmil	2	#2 - 600 kcmil	
			575	60	2	#2 - 600 kcmil	2	#1 ~ 500 kcmil	2	#2 ~ 600 kcmil	
019	5	A	200	60	4	#2 - 600 kcmil					
			230	60	4	#2 - 600 kcmil	4	4/0 ~ 500 kcmil			
			380	60	2	#2 - 600 kcmil	2	#1 ~ 500 kcmil	3	#2 ~ 600 kcmil	
			400	50	2	#2 - 600 kcmil	2	#1 ~ 500 kcmil	3	#2 ~ 600 kcmil	
			460	60	2	#2 - 600 kcmil	2	#1 ~ 500 kcmil	2	#2 - 600 kcmil	
			575	60	2	#2 - 600 kcmil	2	#1 ~ 500 kcmil	2	#2 ~ 600 kcmil	
019	8	B	200	60	4	#2 - 600 kcmil					
			230	60	4	#2 - 600 kcmil	4	4/0 ~ 500 kcmil			
			380	60	2	#2 - 600 kcmil	2	#1 ~ 500 kcmil	3	#2 ~ 600 kcmil	
			400	50	2	#2 - 600 kcmil	2	#1 ~ 500 kcmil	3	#2 ~ 600 kcmil	
			460	60	2	#2 - 600 kcmil	2	#1 ~ 500 kcmil	2	#2 - 600 kcmil	
			575	60	2	#2 - 600 kcmil	2	#1 ~ 500 kcmil	2	#2 ~ 600 kcmil	
020	0	C	200	60	4	#2 - 600 kcmil					
			230	60	4	#2 - 600 kcmil	4	4/0 ~ 500 kcmil			
			380	60	3	#2 - 600 kcmil	3	3/0 ~ 400 kcmil	3	#2 ~ 600 kcmil	
			400	50	3	#2 - 600 kcmil	3	3/0 ~ 400 kcmil	3	#2 ~ 600 kcmil	
			460	60	2	#2 - 600 kcmil	2	#1 ~ 500 kcmil	3	#2 - 600 kcmil	
			575	60	2	#2 - 600 kcmil	2	#1 ~ 500 kcmil	2	#2 ~ 600 kcmil	
021	3	A	200	60	4	#2 - 600 kcmil					
			230	60	4	#2 - 600 kcmil	4	4/0 ~ 500 kcmil			
			380	60	2	#2 - 600 kcmil	2	#1 ~ 500 kcmil	3	#2 ~ 600 kcmil	
			400	50	2	#2 - 600 kcmil	2	#1 ~ 500 kcmil	3	#2 ~ 600 kcmil	
			460	60	2	#2 - 600 kcmil	2	#1 ~ 500 kcmil	2	#2 - 600 kcmil	
			575	60	2	#2 - 600 kcmil	2	#1 ~ 500 kcmil	2	#2 ~ 600 kcmil	

TABLE 4 - ELECTRICAL LUG DATA (CONT'D)

FIELD WIRING LUGS					HIGH AIRFLOW/HIGH STATIC CONDENSER FANS						
					TERMINAL BLOCK		CIRCUIT BREAKER		NON-FUSED DISCONNECT SWITCH		
YVAA MODEL			INPUT VOLTS	INPUT FREQ	WIRE PER PHASE	LUG WIRE RANGE	WIRES PER PHASE	LUG WIRE RANGE	WIRES PER PHASE	LUG WIRE RANGE	
FRAME	COND	EVAP									
SINGLE POINT WIRING											
015	3	B	200	60	4	#1/0 ~ 700 kcmil					
			230	60	4	#2 - 600 kcmil	4	4/0 ~ 500 kcmil			
			380	60	2	#2 - 600 kcmil	2	#1 ~ 500 kcmil	3	#2 ~ 600 kcmil	
			400	50	2	#2 - 600 kcmil	2	#1 ~ 500 kcmil	3	#2 ~ 600 kcmil	
			460	60	2	#2 - 600 kcmil	2	#1 ~ 500 kcmil	3	#2 ~ 600 kcmil	
			575	60	2	#2 - 600 kcmil	2	#1 ~ 500 kcmil	2	#2 ~ 600 kcmil	
016	5	B	200	60	4	#1/0 ~ 700 kcmil					
			230	60	4	#2 - 600 kcmil	4	4/0 ~ 500 kcmil			
			380	60	2	#2 - 600 kcmil	2	#1 ~ 500 kcmil	3	#2 ~ 600 kcmil	
			400	50	2	#2 - 600 kcmil	2	#1 ~ 500 kcmil	3	#2 ~ 600 kcmil	
			460	60	2	#2 - 600 kcmil	2	#1 ~ 500 kcmil	3	#2 ~ 600 kcmil	
			575	60	2	#2 - 600 kcmil	2	#1 ~ 500 kcmil	2	#2 ~ 600 kcmil	
017	8	C	200	60	4	#1/0 ~ 700 kcmil					
			230	60	4	#2 - 600 kcmil	4	4/0 ~ 500 kcmil			
			380	60	2	#2 - 600 kcmil	2	#1 ~ 500 kcmil	3	#2 ~ 600 kcmil	
			400	50	2	#2 - 600 kcmil	2	#1 ~ 500 kcmil	3	#2 ~ 600 kcmil	
			460	60	2	#2 - 600 kcmil	2	#1 ~ 500 kcmil	3	#2 ~ 600 kcmil	
			575	60	2	#2 - 600 kcmil	2	#1 ~ 500 kcmil	2	#2 ~ 600 kcmil	
018	3	A	200	60	4	#1/0 ~ 700 kcmil					
			230	60	4	#2 - 600 kcmil	4	4/0 ~ 500 kcmil			
			380	60	3	#2 - 600 kcmil	3	3/0 ~ 400 kcmil	3	#2 ~ 600 kcmil	
			400	50	3	#2 - 600 kcmil	3	3/0 ~ 400 kcmil	3	#2 ~ 600 kcmil	
			460	60	2	#2 - 600 kcmil	2	#1 ~ 500 kcmil	3	#2 ~ 600 kcmil	
			575	60	2	#2 - 600 kcmil	2	#1 ~ 500 kcmil	2	#2 ~ 600 kcmil	
019	5	A	200	60	4	#1/0 ~ 700 kcmil					
			230	60	4	#2 - 600 kcmil	4	4/0 ~ 500 kcmil			
			380	60	3	#2 - 600 kcmil	3	3/0 ~ 400 kcmil	3	#2 ~ 600 kcmil	
			400	50	3	#2 - 600 kcmil	3	3/0 ~ 400 kcmil	3	#2 ~ 600 kcmil	
			460	60	2	#2 - 600 kcmil	2	#1 ~ 500 kcmil	3	#2 ~ 600 kcmil	
			575	60	2	#2 - 600 kcmil	2	#1 ~ 500 kcmil	2	#2 ~ 600 kcmil	
019	8	B	200	60	4	#1/0 ~ 700 kcmil					
			230	60	4	#2 - 600 kcmil	4	4/0 ~ 500 kcmil			
			380	60	3	#2 - 600 kcmil	3	3/0 ~ 400 kcmil	3	#2 ~ 600 kcmil	
			400	50	3	#2 - 600 kcmil	3	3/0 ~ 400 kcmil	3	#2 ~ 600 kcmil	
			460	60	2	#2 - 600 kcmil	2	#1 ~ 500 kcmil	3	#2 ~ 600 kcmil	
			575	60	2	#2 - 600 kcmil	2	#1 ~ 500 kcmil	2	#2 ~ 600 kcmil	
020	0	C	200	60	4	#1/0 ~ 700 kcmil					
			230	60	4	#2 - 600 kcmil	4	4/0 ~ 500 kcmil			
			380	60	3	#2 - 600 kcmil	3	3/0 ~ 400 kcmil	3	#2 ~ 600 kcmil	
			400	50	3	#2 - 600 kcmil	3	3/0 ~ 400 kcmil	3	#2 ~ 600 kcmil	
			460	60	3	#2 - 600 kcmil	3	3/0 ~ 400 kcmil	3	#2 ~ 600 kcmil	
			575	60	2	#2 - 600 kcmil	2	#1 ~ 500 kcmil	2	#2 ~ 600 kcmil	
021	3	A	200	60	4	#1/0 ~ 700 kcmil					
			230	60	4	#2 - 600 kcmil	4	4/0 ~ 500 kcmil			
			380	60	3	#2 - 600 kcmil	3	3/0 ~ 400 kcmil	3	#2 ~ 600 kcmil	
			400	50	3	#2 - 600 kcmil	3	3/0 ~ 400 kcmil	3	#2 ~ 600 kcmil	
			460	60	2	#2 - 600 kcmil	2	#1 ~ 500 kcmil	3	#2 ~ 600 kcmil	
			575	60	2	#2 - 600 kcmil	2	#1 ~ 500 kcmil	2	#2 ~ 600 kcmil	

4

TABLE 4 - ELECTRICAL LUG DATA (CONT'D)

FIELD WIRING LUGS					STANDARD & ULTRA QUIET CONDENSER FANS						
					TERMINAL BLOCK		CIRCUIT BREAKER		NON-FUSED DISCONNECT SWITCH		
YVAA MODEL			INPUT VOLTS	INPUT FREQ	WIRES PER PHASE	LUG WIRE RANGE	WIRES PER PHASE	LUG WIRE RANGE	WIRES PER PHASE	LUG WIRE RANGE	
FRAME	COND	EVAP									
SINGLE POINT WIRING											
021	5	C	200	60	4	#2 - 600 kcmil					
			230	60	4	#2 - 600 kcmil	4	4/0 ~ 500 kcmil			
			380	60	2	#2 - 600 kcmil	2	#1 ~ 500 kcmil	3	#2 ~ 600 kcmil	
			400	50	2	#2 - 600 kcmil	2	#1 ~ 500 kcmil	3	#2 ~ 600 kcmil	
			460	60	2	#2 - 600 kcmil	2	#1 ~ 500 kcmil	2	#2 - 600 kcmil	
			575	60	2	#2 - 600 kcmil	2	#1 ~ 500 kcmil	2	#2 ~ 600 kcmil	
021	8	C	200	60	4	#2 - 600 kcmil					
			230	60	4	#2 - 600 kcmil	4	4/0 ~ 500 kcmil			
			380	60	2	#2 - 600 kcmil	2	#1 ~ 500 kcmil	3	#2 ~ 600 kcmil	
			400	50	2	#2 - 600 kcmil	2	#1 ~ 500 kcmil	3	#2 ~ 600 kcmil	
			460	60	2	#2 - 600 kcmil	2	#1 ~ 500 kcmil	2	#2 - 600 kcmil	
			575	60	2	#2 - 600 kcmil	2	#1 ~ 500 kcmil	2	#2 ~ 600 kcmil	
023	3	B	200	60	4	#2 - 600 kcmil					
			230	60	4	#2 - 600 kcmil	4	4/0 ~ 500 kcmil			
			380	60	3	#2 - 600 kcmil	3	3/0 ~ 400 kcmil	3	#2 ~ 600 kcmil	
			400	50	3	#2 - 600 kcmil	3	3/0 ~ 400 kcmil	3	#2 ~ 600 kcmil	
			460	60	2	#2 - 600 kcmil	2	#1 ~ 500 kcmil	3	#2 ~ 600 kcmil	
			575	60	2	#2 - 600 kcmil	2	#1 ~ 500 kcmil	2	#2 ~ 600 kcmil	
024	5	C	200	60	4	#2 - 600 kcmil					
			230	60	4	#2 - 600 kcmil	4	4/0 ~ 500 kcmil			
			380	60	3	#2 - 600 kcmil	3	3/0 ~ 400 kcmil	3	#2 ~ 600 kcmil	
			400	50	3	#2 - 600 kcmil	3	3/0 ~ 400 kcmil	3	#2 ~ 600 kcmil	
			460	60	2	#2 - 600 kcmil	2	#1 ~ 500 kcmil	3	#2 ~ 600 kcmil	
			575	60	2	#2 - 600 kcmil	2	#1 ~ 500 kcmil	2	#2 ~ 600 kcmil	
024	8	C	200	60	4	#2 - 600 kcmil					
			230	60	4	#2 - 600 kcmil	4	4/0 ~ 500 kcmil			
			380	60	3	#2 - 600 kcmil	3	3/0 ~ 400 kcmil	3	#2 ~ 600 kcmil	
			400	50	3	#2 - 600 kcmil	3	3/0 ~ 400 kcmil	3	#2 ~ 600 kcmil	
			460	60	2	#2 - 600 kcmil	2	#1 ~ 500 kcmil	3	#2 ~ 600 kcmil	
			575	60	2	#2 - 600 kcmil	2	#1 ~ 500 kcmil	2	#2 ~ 600 kcmil	
026	3	B	200	60	4	#2 - 600 kcmil					
			230	60	4	#2 - 600 kcmil	4	4/0 ~ 500 kcmil			
			380	60	3	#2 - 600 kcmil	3	3/0 ~ 400 kcmil	3	#2 ~ 600 kcmil	
			400	50	3	#2 - 600 kcmil	3	3/0 ~ 400 kcmil	3	#2 ~ 600 kcmil	
			460	60	2	#2 - 600 kcmil	2	#1 ~ 500 kcmil	3	#2 ~ 600 kcmil	
			575	60	2	#2 - 600 kcmil	2	#1 ~ 500 kcmil	2	#2 ~ 600 kcmil	
027	3	D	200	60	4	#2 - 600 kcmil					
			230	60	4	#2 - 600 kcmil	4	4/0 ~ 500 kcmil			
			380	60	3	#2 - 600 kcmil	3	3/0 ~ 400 kcmil	3	#2 ~ 600 kcmil	
			400	50	3	#2 - 600 kcmil	3	3/0 ~ 400 kcmil	3	#2 ~ 600 kcmil	
			460	60	2	#2 - 600 kcmil	2	#1 ~ 500 kcmil	3	#2 ~ 600 kcmil	
			575	60	2	#2 - 600 kcmil	2	#1 ~ 500 kcmil	2	#2 ~ 600 kcmil	
027	5	E	200	60	4	#2 - 600 kcmil					
			230	60	4	#2 - 600 kcmil	4	4/0 ~ 500 kcmil			
			380	60	3	#2 - 600 kcmil	3	3/0 ~ 400 kcmil	3	#2 ~ 600 kcmil	
			400	50	3	#2 - 600 kcmil	3	3/0 ~ 400 kcmil	3	#2 ~ 600 kcmil	
			460	60	2	#2 - 600 kcmil	2	#1 ~ 500 kcmil	3	#2 ~ 600 kcmil	
			575	60	2	#2 - 600 kcmil	2	#1 ~ 500 kcmil	2	#2 ~ 600 kcmil	
027	8	E	200	60	4	#2 - 600 kcmil					
			230	60	4	#2 - 600 kcmil	4	4/0 ~ 500 kcmil			
			380	60	3	#2 - 600 kcmil	3	3/0 ~ 400 kcmil	3	#2 ~ 600 kcmil	
			400	50	3	#2 - 600 kcmil	3	3/0 ~ 400 kcmil	3	#2 ~ 600 kcmil	
			460	60	2	#2 - 600 kcmil	2	#1 ~ 500 kcmil	3	#2 ~ 600 kcmil	
			575	60	2	#2 - 600 kcmil	2	#1 ~ 500 kcmil	2	#2 ~ 600 kcmil	

TABLE 4 - ELECTRICAL LUG DATA (CONT'D)

FIELD WIRING LUGS					HIGH AIRFLOW/HIGH STATIC CONDENSER FANS						
					TERMINAL BLOCK		CIRCUIT BREAKER		NON-FUSED DISCONNECT SWITCH		
YVAA MODEL			INPUT VOLTS	INPUT FREQ	WIRE PER PHASE	LUG WIRE RANGE	WIRES PER PHASE	LUG WIRE RANGE	WIRES PER PHASE	LUG WIRE RANGE	
FRAME	COND	EVAP									
SINGLE POINT WIRING											
021	5	C	200	60	4	#1/0 ~ 700 kcmil					
			230	60	4	#2 - 600 kcmil	4	4/0 ~ 500 kcmil			
			380	60	3	#2 - 600 kcmil	3	3/0 ~ 400 kcmil	3	#2 ~ 600 kcmil	
			400	50	3	#2 - 600 kcmil	3	3/0 ~ 400 kcmil	3	#2 ~ 600 kcmil	
			460	60	2	#2 - 600 kcmil	2	#1 ~ 500 kcmil	3	#2 ~ 600 kcmil	
			575	60	2	#2 - 600 kcmil	2	#1 ~ 500 kcmil	2	#2 ~ 600 kcmil	
021	8	C	200	60	4	#1/0 ~ 700 kcmil					
			230	60	4	#2 - 600 kcmil	4	4/0 ~ 500 kcmil			
			380	60	3	#2 - 600 kcmil	3	3/0 ~ 400 kcmil	3	#2 ~ 600 kcmil	
			400	50	3	#2 - 600 kcmil	3	3/0 ~ 400 kcmil	3	#2 ~ 600 kcmil	
			460	60	2	#2 - 600 kcmil	2	#1 ~ 500 kcmil	3	#2 ~ 600 kcmil	
			575	60	2	#2 - 600 kcmil	2	#1 ~ 500 kcmil	2	#2 ~ 600 kcmil	
023	3	B	200	60	4	#1/0 ~ 700 kcmil					
			230	60	4	#2 - 600 kcmil	4	4/0 ~ 500 kcmil			
			380	60	3	#2 - 600 kcmil	3	3/0 ~ 400 kcmil	3	#2 ~ 600 kcmil	
			400	50	3	#2 - 600 kcmil	3	3/0 ~ 400 kcmil	3	#2 ~ 600 kcmil	
			460	60	3	#2 - 600 kcmil	3	3/0 ~ 400 kcmil	3	#2 ~ 600 kcmil	
			575	60	2	#2 - 600 kcmil	2	#1 - 500 kcmil	2	#2 ~ 600 kcmil	
024	5	C	200	60	4	#1/0 ~ 700 kcmil					
			230	60	4	#2 - 600 kcmil	4	4/0 ~ 500 kcmil			
			380	60	3	#2 - 600 kcmil	3	3/0 ~ 400 kcmil	3	#2 ~ 600 kcmil	
			400	50	3	#2 - 600 kcmil	3	3/0 ~ 400 kcmil	3	#2 ~ 600 kcmil	
			460	60	3	#2 - 600 kcmil	3	3/0 ~ 400 kcmil	3	#2 ~ 600 kcmil	
			575	60	2	#2 - 600 kcmil	2	#1 - 500 kcmil	2	#2 ~ 600 kcmil	
024	8	C	200	60	4	#1/0 ~ 700 kcmil					
			230	60	4	#2 - 600 kcmil	4	4/0 ~ 500 kcmil			
			380	60	3	#2 - 600 kcmil	3	3/0 ~ 400 kcmil	3	#2 ~ 600 kcmil	
			400	50	3	#2 - 600 kcmil	3	3/0 ~ 400 kcmil	3	#2 ~ 600 kcmil	
			460	60	3	#2 - 600 kcmil	3	3/0 ~ 400 kcmil	3	#2 ~ 600 kcmil	
			575	60	2	#2 - 600 kcmil	2	#1 - 500 kcmil	2	#2 ~ 600 kcmil	
026	3	B	200	60	4	#1/0 ~ 700 kcmil					
			230	60	4	#2 - 600 kcmil	4	4/0 ~ 500 kcmil			
			380	60	3	#2 - 600 kcmil	3	3/0 ~ 400 kcmil	3	#2 ~ 600 kcmil	
			400	50	3	#2 - 600 kcmil	3	3/0 ~ 400 kcmil	3	#2 ~ 600 kcmil	
			460	60	3	#2 - 600 kcmil	3	3/0 ~ 400 kcmil	3	#2 ~ 600 kcmil	
			575	60	2	#2 - 600 kcmil	2	#1 - 500 kcmil	2	#2 ~ 600 kcmil	
027	3	D	200	60	4	#1/0 ~ 700 kcmil					
			230	60	4	#2 - 600 kcmil	4	4/0 ~ 500 kcmil			
			380	60	3	#2 - 600 kcmil	3	3/0 ~ 400 kcmil	3	#2 ~ 600 kcmil	
			400	50	3	#2 - 600 kcmil	3	3/0 ~ 400 kcmil	3	#2 ~ 600 kcmil	
			460	60	3	#2 - 600 kcmil	3	3/0 ~ 400 kcmil	3	#2 ~ 600 kcmil	
			575	60	2	#2 - 600 kcmil	2	#1 ~ 500 kcmil	2	#2 ~ 600 kcmil	
027	5	E	200	60	4	#1/0 ~ 700 kcmil					
			230	60	4	#2 - 600 kcmil	4	4/0 ~ 500 kcmil			
			380	60	3	#2 - 600 kcmil	3	3/0 ~ 400 kcmil	3	#2 ~ 600 kcmil	
			400	50	3	#2 - 600 kcmil	3	3/0 ~ 400 kcmil	3	#2 ~ 600 kcmil	
			460	60	3	#2 - 600 kcmil	3	3/0 ~ 400 kcmil	3	#2 ~ 600 kcmil	
			575	60	2	#2 - 600 kcmil	2	#1 - 500 kcmil	2	#2 ~ 600 kcmil	
027	8	E	200	60	4	#1/0 ~ 700 kcmil					
			230	60	4	#2 - 600 kcmil	4	4/0 ~ 500 kcmil			
			380	60	3	#2 - 600 kcmil	3	3/0 ~ 400 kcmil	3	#2 ~ 600 kcmil	
			400	50	3	#2 - 600 kcmil	3	3/0 ~ 400 kcmil	3	#2 ~ 600 kcmil	
			460	60	3	#2 - 600 kcmil	3	3/0 ~ 400 kcmil	3	#2 ~ 600 kcmil	
			575	60	2	#2 - 600 kcmil	2	#1 - 500 kcmil	2	#2 ~ 600 kcmil	

4

TABLE 4 - ELECTRICAL LUG DATA (CONT'D)

FIELD WIRING LUGS					STANDARD & ULTRA QUIET CONDENSER FANS					
					TERMINAL BLOCK		CIRCUIT BREAKER		NON-FUSED DISCONNECT SWITCH	
YVAA MODEL			INPUT VOLTS	INPUT FREQ	WIRES PER PHASE	LUG WIRE RANGE	WIRES PER PHASE	LUG WIRE RANGE	WIRES PER PHASE	LUG WIRE RANGE
FRAME	COND	EVAP								
SINGLE POINT WIRING										
029	5	E	200	60						
			230	60						
			380	60	3	#2 - 600 kcmil	4	#4/0 ~ 500 kcmil	4*	#2 - 600 kcmil
			400	50	3	#2 - 600 kcmil	4	#4/0 ~ 500 kcmil	3	#2 ~ 600 kcmil
			460	60	3	#2 - 600 kcmil	3	#3/0 ~ 400 kcmil	3	#2 ~ 600 kcmil
			575	60	3	#2 - 600 kcmil	3	#3/0 ~ 400 kcmil	3	#2 ~ 600 kcmil
030	3	C	200	60						
			230	60						
			380	60	3	#2 - 600 kcmil	4	#4/0 ~ 500 kcmil	4*	#2 - 600 kcmil
			400	50	3	#2 - 600 kcmil	4	#4/0 ~ 500 kcmil	3	#2 ~ 600 kcmil
			460	60	3	#2 - 600 kcmil	3	#3/0 ~ 400 kcmil	3	#2 ~ 600 kcmil
			575	60	3	#2 - 600 kcmil	3	#3/0 ~ 400 kcmil	3	#2 ~ 600 kcmil
030	5	C	200	60						
			230	60						
			380	60	3	#2 - 600 kcmil	4	#4/0 ~ 500 kcmil	4*	#2 - 600 kcmil
			400	50	3	#2 - 600 kcmil	4	#4/0 ~ 500 kcmil	3	#2 ~ 600 kcmil
			460	60	3	#2 - 600 kcmil	3	#3/0 ~ 400 kcmil	3	#2 ~ 600 kcmil
			575	60	3	#2 - 600 kcmil	3	#3/0 ~ 400 kcmil	3	#2 ~ 600 kcmil
030	8	E	200	60						
			230	60						
			380	60	3	#2 - 600 kcmil	4	#4/0 ~ 500 kcmil	4*	#2 - 600 kcmil
			400	50	3	#2 - 600 kcmil	4	#4/0 ~ 500 kcmil	3	#2 ~ 600 kcmil
			460	60	3	#2 - 600 kcmil	3	#3/0 ~ 400 kcmil	3	#2 ~ 600 kcmil
			575	60	3	#2 - 600 kcmil	3	#3/0 ~ 400 kcmil	3	#2 ~ 600 kcmil
031	8	E	200	60						
			230	60						
			380	60	3	#2 - 600 kcmil	4	#4/0 ~ 500 kcmil	4*	#2 - 600 kcmil
			400	50	3	#2 - 600 kcmil	4	#4/0 ~ 500 kcmil	3	#2 ~ 600 kcmil
			460	60	3	#2 - 600 kcmil	3	#3/0 ~ 400 kcmil	3	#2 ~ 600 kcmil
			575	60	3	#2 - 600 kcmil	3	#3/0 ~ 400 kcmil	3	#2 ~ 600 kcmil
032	3	E	200	60						
			230	60						
			380	60	3	#2 - 600 kcmil	4	#4/0 ~ 500 kcmil	4*	#2 - 600 kcmil
			400	50	3	#2 - 600 kcmil	4	#4/0 ~ 500 kcmil	3	#2 ~ 600 kcmil
			460	60	3	#2 - 600 kcmil	3	#3/0 ~ 400 kcmil	3	#2 ~ 600 kcmil
			575	60	3	#2 - 600 kcmil	3	#3/0 ~ 400 kcmil	3	#2 ~ 600 kcmil
033	3	C	200	60						
			230	60						
			380	60	3	#2 - 600 kcmil	4	#4/0 ~ 500 kcmil	4*	#2 - 600 kcmil
			400	50	3	#2 - 600 kcmil	4	#4/0 ~ 500 kcmil	3	#2 ~ 600 kcmil
			460	60	3	#2 - 600 kcmil	3	#3/0 ~ 400 kcmil	3	#2 ~ 600 kcmil
			575	60	3	#2 - 600 kcmil	3	#3/0 ~ 400 kcmil	3	#2 ~ 600 kcmil
034	3	E	200	60						
			230	60						
			380	60	3	#2 - 600 kcmil	4	#4/0 ~ 500 kcmil	4*	#2 - 600 kcmil
			400	50	3	#2 - 600 kcmil	4	#4/0 ~ 500 kcmil	3	#2 ~ 600 kcmil
			460	60	3	#2 - 600 kcmil	3	#3/0 ~ 400 kcmil	3	#2 ~ 600 kcmil
			575	60	3	#2 - 600 kcmil	3	#3/0 ~ 400 kcmil	3	#2 ~ 600 kcmil
034	5	E	200	60						
			230	60						
			380	60	3	#2 - 600 kcmil	4	#4/0 ~ 500 kcmil	4*	#2 - 600 kcmil
			400	50	3	#2 - 600 kcmil	4	#4/0 ~ 500 kcmil	3	#2 ~ 600 kcmil
			460	60	3	#2 - 600 kcmil	3	#3/0 ~ 400 kcmil	3	#2 ~ 600 kcmil
			575	60	3	#2 - 600 kcmil	3	#3/0 ~ 400 kcmil	3	#2 ~ 600 kcmil

TABLE 4 - ELECTRICAL LUG DATA (CONT'D)

FIELD WIRING LUGS					HIGH AIRFLOW/HIGH STATIC CONDENSER FANS						
					TERMINAL BLOCK		CIRCUIT BREAKER		NON-FUSED DISCONNECT SWITCH		
YVAA MODEL			INPUT VOLTS	INPUT FREQ	WIRE PER PHASE	LUG WIRE RANGE	WIRES PER PHASE	LUG WIRE RANGE	WIRES PER PHASE	LUG WIRE RANGE	
FRAME	COND	EVAP									
SINGLE POINT WIRING											
029	5	E	200	60							
			230	60							
			380	60	4	#2 - 600 kcmil	4	#4/0 ~ 500 kcmil	4*	#2 - 600 kcmil	
			400	50	4	#2 - 600 kcmil	4	#4/0 ~ 500 kcmil	4*	#2 - 600 kcmil	
			460	60	3	#2 - 600 kcmil	4	#4/0 ~ 500 kcmil	3	#2 - 600 kcmil	
			575	60	3	#2 - 600 kcmil	3	#3/0 ~ 400 kcmil	3	#2 - 600 kcmil	
030	3	C	200	60							
			230	60							
			380	60	4	#2 - 600 kcmil	4	#4/0 ~ 500 kcmil	4*	#2 - 600 kcmil	
			400	50	4	#2 - 600 kcmil	4	#4/0 ~ 500 kcmil	4*	#2 - 600 kcmil	
			460	60	3	#2 - 600 kcmil	4	#4/0 ~ 500 kcmil	3	#2 - 600 kcmil	
			575	60	3	#2 - 600 kcmil	3	#3/0 ~ 400 kcmil	3	#2 - 600 kcmil	
030	5	C	200	60							
			230	60							
			380	60	4	#2 - 600 kcmil	4	#4/0 ~ 500 kcmil	4*	#2 - 600 kcmil	
			400	50	4	#2 - 600 kcmil	4	#4/0 ~ 500 kcmil	4*	#2 - 600 kcmil	
			460	60	3	#2 - 600 kcmil	4	#4/0 ~ 500 kcmil	3	#2 - 600 kcmil	
			575	60	3	#2 - 600 kcmil	3	#3/0 ~ 400 kcmil	3	#2 - 600 kcmil	
030	8	E	200	60							
			230	60							
			380	60	4	#2 - 600 kcmil	4	#4/0 ~ 500 kcmil	4*	#2 - 600 kcmil	
			400	50	4	#2 - 600 kcmil	4	#4/0 ~ 500 kcmil	4*	#2 - 600 kcmil	
			460	60	3	#2 - 600 kcmil	4	#4/0 ~ 500 kcmil	3	#2 - 600 kcmil	
			575	60	3	#2 - 600 kcmil	3	#3/0 ~ 400 kcmil	3	#2 - 600 kcmil	
031	8	E	200	60							
			230	60							
			380	60	4	#2 - 600 kcmil	4	#4/0 ~ 500 kcmil	4*	#2 - 600 kcmil	
			400	50	4	#2 - 600 kcmil	4	#4/0 ~ 500 kcmil	4*	#2 - 600 kcmil	
			460	60	3	#2 - 600 kcmil	4	#4/0 ~ 500 kcmil	3	#2 - 600 kcmil	
			575	60	3	#2 - 600 kcmil	3	#3/0 ~ 400 kcmil	3	#2 - 600 kcmil	
032	3	E	200	60							
			230	60							
			380	60	4	#2 - 600 kcmil	4	#4/0 ~ 500 kcmil	4*	#2 - 600 kcmil	
			400	50	4	#2 - 600 kcmil	4	#4/0 ~ 500 kcmil	4*	#2 - 600 kcmil	
			460	60	3	#2 - 600 kcmil	4	#4/0 ~ 500 kcmil	3	#2 - 600 kcmil	
			575	60	3	#2 - 600 kcmil	3	#3/0 ~ 400 kcmil	3	#2 - 600 kcmil	
033	3	C	200	60							
			230	60							
			380	60	4	#2 - 600 kcmil	4	#4/0 ~ 500 kcmil	4*	#2 - 600 kcmil	
			400	50	4	#2 - 600 kcmil	4	#4/0 ~ 500 kcmil	4*	#2 - 600 kcmil	
			460	60	3	#2 - 600 kcmil	4	#4/0 ~ 500 kcmil	3	#2 - 600 kcmil	
			575	60	3	#2 - 600 kcmil	3	#3/0 ~ 400 kcmil	3	#2 - 600 kcmil	
034	3	E	200	60							
			230	60							
			380	60	4	#2 - 600 kcmil	4	#4/0 ~ 500 kcmil	4*	#2 - 600 kcmil	
			400	50	4	#2 - 600 kcmil	4	#4/0 ~ 500 kcmil	4*	#2 - 600 kcmil	
			460	60	3	#2 - 600 kcmil	4	#4/0 ~ 500 kcmil	3	#2 - 600 kcmil	
			575	60	3	#2 - 600 kcmil	3	#3/0 ~ 400 kcmil	3	#2 - 600 kcmil	
034	5	E	200	60							
			230	60							
			380	60	4	#2 - 600 kcmil	4	#4/0 ~ 500 kcmil	4*	#2 - 600 kcmil	
			400	50	4	#2 - 600 kcmil	4	#4/0 ~ 500 kcmil	4*	#2 - 600 kcmil	
			460	60	3	#2 - 600 kcmil	4	#4/0 ~ 500 kcmil	3	#2 - 600 kcmil	
			575	60	3	#2 - 600 kcmil	3	#3/0 ~ 400 kcmil	3	#2 - 600 kcmil	

4

TABLE 4 - ELECTRICAL LUG DATA (CONT'D)

FIELD WIRING LUGS					STANDARD & ULTRA QUIET CONDENSER FANS					
					TERMINAL BLOCK		CIRCUIT BREAKER		NON-FUSED DISCONNECT SWITCH	
YVAA MODEL			INPUT VOLTS	INPUT FREQ	WIRES PER PHASE	LUG WIRE RANGE	WIRES PER PHASE	LUG WIRE RANGE	WIRES PER PHASE	LUG WIRE RANGE
FRAME	COND	EVAP								
DUAL POINT WIRING										
036	8	J	200	60						
			230	60						
			380	60	3	#2 - 600 kcmil	3	#3/0 ~ 400 kcmil	3	#3/0 ~ 400 kcmil
			400	50	3	#2 - 600 kcmil	3	#3/0 ~ 400 kcmil	3	#3/0 ~ 400 kcmil
			460	60	2	#2 - 600 kcmil	2	#1 ~ 500 kcmil	2	#1 ~ 500 kcmil
			575	60	2	#2 - 600 kcmil	2	#1 ~ 500 kcmil	2	#1 ~ 500 kcmil
037	3	F	200	60						
			230	60						
			380	60	3	#2 - 600 kcmil	3	#3/0 ~ 400 kcmil	3	#3/0 ~ 400 kcmil
			400	50	3	#2 - 600 kcmil	3	#3/0 ~ 400 kcmil	3	#3/0 ~ 400 kcmil
			460	60	2	#2 - 600 kcmil	2	#1 ~ 500 kcmil	2	#1 ~ 500 kcmil
			575	60	2	#2 - 600 kcmil	2	#1 ~ 500 kcmil	2	#1 ~ 500 kcmil
037	5	J	200	60						
			230	60						
			380	60	3	#2 - 600 kcmil	3	#3/0 ~ 400 kcmil	3	#3/0 ~ 400 kcmil
			400	50	3	#2 - 600 kcmil	3	#3/0 ~ 400 kcmil	3	#3/0 ~ 400 kcmil
			460	60	2	#2 - 600 kcmil	2	#1 ~ 500 kcmil	2	#1 ~ 500 kcmil
			575	60	2	#2 - 600 kcmil	2	#1 ~ 500 kcmil	2	#1 ~ 500 kcmil
039	8	J	200	60						
			230	60						
			380	60	3	#2 - 600 kcmil	3	#3/0 ~ 400 kcmil	3	#3/0 ~ 400 kcmil
			400	50	3	#2 - 600 kcmil	3	#3/0 ~ 400 kcmil	3	#3/0 ~ 400 kcmil
			460	60	2	#2 - 600 kcmil	2	#1 ~ 500 kcmil	2	#1 ~ 500 kcmil
			575	60	2	#2 - 600 kcmil	2	#1 ~ 500 kcmil	2	#1 ~ 500 kcmil
041	3	H	200	60						
			230	60						
			380	60	3	#2 - 600 kcmil	3	#3/0 ~ 400 kcmil	3	#3/0 ~ 400 kcmil
			400	50	3	#2 - 600 kcmil	3	#3/0 ~ 400 kcmil	3	#3/0 ~ 400 kcmil
			460	60	2	#2 - 600 kcmil	2	#1 ~ 500 kcmil	2	#1 ~ 500 kcmil
			575	60	2	#2 - 600 kcmil	2	#1 ~ 500 kcmil	2	#1 ~ 500 kcmil
042	5	H	200	60						
			230	60						
			380	60	3	#2 - 600 kcmil	3	#3/0 ~ 400 kcmil	3	#3/0 ~ 400 kcmil
			400	50	3	#2 - 600 kcmil	3	#3/0 ~ 400 kcmil	3	#3/0 ~ 400 kcmil
			460	60	2	#2 - 600 kcmil	2	#1 ~ 500 kcmil	2	#1 ~ 500 kcmil
			575	60	2	#2 - 600 kcmil	2	#1 ~ 500 kcmil	2	#1 ~ 500 kcmil
042	8	J	200	60						
			230	60						
			380	60	3	#2 - 600 kcmil	3	#3/0 ~ 400 kcmil	3	#3/0 ~ 400 kcmil
			400	50	3	#2 - 600 kcmil	3	#3/0 ~ 400 kcmil	3	#3/0 ~ 400 kcmil
			460	60	2	#2 - 600 kcmil	2	#1 ~ 500 kcmil	2	#1 ~ 500 kcmil
			575	60	2	#2 - 600 kcmil	2	#1 ~ 500 kcmil	2	#1 ~ 500 kcmil
044	3	G	200	60						
			230	60						
			380	60	3	#2 - 600 kcmil	3	#3/0 ~ 400 kcmil	3	#3/0 ~ 400 kcmil
			400	50	3	#2 - 600 kcmil	3	#3/0 ~ 400 kcmil	3	#3/0 ~ 400 kcmil
			460	60	2	#2 - 600 kcmil	2	#1 ~ 500 kcmil	2	#1 ~ 500 kcmil
			575	60	2	#2 - 600 kcmil	2	#1 ~ 500 kcmil	2	#1 ~ 500 kcmil
047	5	J	200	60						
			230	60						
			380	60	3	#2 - 600 kcmil	3	#3/0 ~ 400 kcmil	3	#3/0 ~ 400 kcmil
			400	50	3	#2 - 600 kcmil	3	#3/0 ~ 400 kcmil	3	#3/0 ~ 400 kcmil
			460	60	2	#2 - 600 kcmil	2	#1 ~ 500 kcmil	2	#1 ~ 500 kcmil
			575	60	2	#2 - 600 kcmil	2	#1 ~ 500 kcmil	2	#1 ~ 500 kcmil

TABLE 4 - ELECTRICAL LUG DATA (CONT'D)

FIELD WIRING LUGS					HIGH AIRFLOW/HIGH STATIC CONDENSER FANS					
					TERMINAL BLOCK		CIRCUIT BREAKER		NON-FUSED DISCONNECT SWITCH	
YVAA MODEL			INPUT VOLTS	INPUT FREQ	WIRE PER PHASE	LUG WIRE RANGE	WIRES PER PHASE	LUG WIRE RANGE	WIRES PER PHASE	LUG WIRE RANGE
FRAME	COND	EVAP								
DUAL POINT WIRING										
036	8	J	200	60						
			230	60						
			380	60	3	#2 - 600 kcmil	3	#3/0 ~ 400 kcmil	3	#3/0 ~ 400 kcmil
			400	50	3	#2 - 600 kcmil	3	#3/0 ~ 400 kcmil	3	#3/0 ~ 400 kcmil
			460	60	2	#2 - 600 kcmil	3	#3/0 ~ 400 kcmil	3	#3/0 ~ 400 kcmil
			575	60	2	#2 - 600 kcmil	2	#1 ~ 500 kcmil	2	#1 ~ 500 kcmil
037	3	F	200	60						
			230	60						
			380	60	3	#2 - 600 kcmil	3	#3/0 ~ 400 kcmil	3	#3/0 ~ 400 kcmil
			400	50	3	#2 - 600 kcmil	3	#3/0 ~ 400 kcmil	3	#3/0 ~ 400 kcmil
			460	60	2	#2 - 600 kcmil	3	#3/0 ~ 400 kcmil	3	#3/0 ~ 400 kcmil
			575	60	2	#2 - 600 kcmil	2	#1 ~ 500 kcmil	2	#1 ~ 500 kcmil
037	5	J	200	60						
			230	60						
			380	60	3	#2 - 600 kcmil	3	#3/0 ~ 400 kcmil	3	#3/0 ~ 400 kcmil
			400	50	3	#2 - 600 kcmil	3	#3/0 ~ 400 kcmil	3	#3/0 ~ 400 kcmil
			460	60	2	#2 - 600 kcmil	3	#3/0 ~ 400 kcmil	3	#3/0 ~ 400 kcmil
			575	60	2	#2 - 600 kcmil	2	#1 ~ 500 kcmil	2	#1 ~ 500 kcmil
039	8	J	200	60						
			230	60						
			380	60	3	#2 - 600 kcmil	3	#3/0 ~ 400 kcmil	3	#3/0 ~ 400 kcmil
			400	50	3	#2 - 600 kcmil	3	#3/0 ~ 400 kcmil	3	#3/0 ~ 400 kcmil
			460	60	2	#2 - 600 kcmil	3	#3/0 ~ 400 kcmil	3	#3/0 ~ 400 kcmil
			575	60	2	#2 - 600 kcmil	2	#1 ~ 500 kcmil	2	#1 ~ 500 kcmil
041	3	H	200	60						
			230	60						
			380	60	3	#2 - 600 kcmil	3	#3/0 ~ 400 kcmil	3	#3/0 ~ 400 kcmil
			400	50	3	#2 - 600 kcmil	3	#3/0 ~ 400 kcmil	3	#3/0 ~ 400 kcmil
			460	60	2	#2 - 600 kcmil	3	#3/0 ~ 400 kcmil	3	#3/0 ~ 400 kcmil
			575	60	2	#2 - 600 kcmil	2	#1 ~ 500 kcmil	2	#1 ~ 500 kcmil
042	5	H	200	60						
			230	60						
			380	60	3	#2 - 600 kcmil	3	#3/0 ~ 400 kcmil	3	#3/0 ~ 400 kcmil
			400	50	3	#2 - 600 kcmil	3	#3/0 ~ 400 kcmil	3	#3/0 ~ 400 kcmil
			460	60	2	#2 - 600 kcmil	3	#3/0 ~ 400 kcmil	3	#3/0 ~ 400 kcmil
			575	60	2	#2 - 600 kcmil	2	#1 ~ 500 kcmil	2	#1 ~ 500 kcmil
042	8	J	200	60						
			230	60						
			380	60	3	#2 - 600 kcmil	3	#3/0 ~ 400 kcmil	3	#3/0 ~ 400 kcmil
			400	50	3	#2 - 600 kcmil	3	#3/0 ~ 400 kcmil	3	#3/0 ~ 400 kcmil
			460	60	2	#2 - 600 kcmil	3	#3/0 ~ 400 kcmil	3	#3/0 ~ 400 kcmil
			575	60	2	#2 - 600 kcmil	2	#1 ~ 500 kcmil	2	#1 ~ 500 kcmil
044	3	G	200	60						
			230	60						
			380	60	3	#2 - 600 kcmil	3	#3/0 ~ 400 kcmil	3	#3/0 ~ 400 kcmil
			400	50	3	#2 - 600 kcmil	3	#3/0 ~ 400 kcmil	3	#3/0 ~ 400 kcmil
			460	60	2	#2 - 600 kcmil	3	#3/0 ~ 400 kcmil	3	#3/0 ~ 400 kcmil
			575	60	2	#2 - 600 kcmil	2	#1 ~ 500 kcmil	2	#1 ~ 500 kcmil
047	5	J	200	60						
			230	60						
			380	60	3	#2 - 600 kcmil	3	#3/0 ~ 400 kcmil	3	#3/0 ~ 400 kcmil
			400	50	3	#2 - 600 kcmil	3	#3/0 ~ 400 kcmil	3	#3/0 ~ 400 kcmil
			460	60	2	#2 - 600 kcmil	3	#3/0 ~ 400 kcmil	3	#3/0 ~ 400 kcmil
			575	60	2	#2 - 600 kcmil	2	#1 ~ 500 kcmil	2	#1 ~ 500 kcmil

4

TABLE 4 - ELECTRICAL LUG DATA (CONT'D)

FIELD WIRING LUGS					STANDARD & ULTRA QUIET CONDENSER FANS					
					TERMINAL BLOCK		CIRCUIT BREAKER		NON-FUSED DISCONNECT SWITCH	
YVAA MODEL			INPUT VOLTS	INPUT FREQ	WIRE PER PHASE	LUG WIRE RANGE	WIRES PER PHASE	LUG WIRE RANGE	WIRES PER PHASE	LUG WIRE RANGE
FRAME	COND	EVAP								
DUAL POINT WIRING										
048	3	G	200	60						
			230	60						
			380	60	3	#2 - 600 kcmil	3	#3/0 ~ 400 kcmil	3	#3/0 ~ 400 kcmil
			400	50	3	#2 - 600 kcmil	3	#3/0 ~ 400 kcmil	3	#3/0 ~ 400 kcmil
			460	60	2	#2 - 600 kcmil	2	#1 ~ 500 kcmil	2	#1 ~ 500 kcmil
			575	60	2	#2 - 600 kcmil	2	#1 ~ 500 kcmil	2	#1 ~ 500 kcmil
050	0	J	200	60						
			230	60						
			380	60	3	#2 - 600 kcmil	3	#3/0 ~ 400 kcmil	3	#3/0 ~ 400 kcmil
			400	50	3	#2 - 600 kcmil	3	#3/0 ~ 400 kcmil	3	#3/0 ~ 400 kcmil
			460	60	2	#2 - 600 kcmil	2	#1 ~ 500 kcmil	2	#1 ~ 500 kcmil
			575	60	2	#2 - 600 kcmil	2	#1 ~ 500 kcmil	2	#1 ~ 500 kcmil
052	3	J	200	60						
			230	60						
			380	60	3	#2 - 600 kcmil	3	#3/0 ~ 400 kcmil	3	#3/0 ~ 400 kcmil
			400	50	3	#2 - 600 kcmil	3	#3/0 ~ 400 kcmil	3	#3/0 ~ 400 kcmil
			460	60	2	#2 - 600 kcmil	2	#1 ~ 500 kcmil	2	#1 ~ 500 kcmil
			575	60	2	#2 - 600 kcmil	2	#1 ~ 500 kcmil	2	#1 ~ 500 kcmil

TABLE 4 - ELECTRICAL LUG DATA (CONT'D)

FIELD WIRING LUGS					HIGH AIRFLOW/HIGH STATIC CONDENSER FANS					
					TERMINAL BLOCK		CIRCUIT BREAKER		NON-FUSED DISCONNECT SWITCH	
YVAA MODEL			INPUT VOLTS	INPUT FREQ	WIRE PER PHASE	LUG WIRE RANGE	WIRES PER PHASE	LUG WIRE RANGE	WIRES PER PHASE	LUG WIRE RANGE
FRAME	COND	EVAP								
DUAL POINT WIRING										
048	3	G	200	60						
			230	60						
			380	60	3	#2 - 600 kcmil	3	#3/0 ~ 400 kcmil	3	#3/0 ~ 400 kcmil
			400	50	3	#2 - 600 kcmil	3	#3/0 ~ 400 kcmil	3	#3/0 ~ 400 kcmil
			460	60	2	#2 - 600 kcmil	3	#3/0 ~ 400 kcmil	3	#3/0 ~ 400 kcmil
			575	60	2	#2 - 600 kcmil	2	#1 ~ 500 kcmil	2	#1 ~ 500 kcmil
050	0	J	200	60						
			230	60						
			380	60	3	#2 - 600 kcmil	3	#3/0 ~ 400 kcmil	3	#3/0 ~ 400 kcmil
			400	50	3	#2 - 600 kcmil	3	#3/0 ~ 400 kcmil	3	#3/0 ~ 400 kcmil
			460	60	2	#2 - 600 kcmil	3	#3/0 ~ 400 kcmil	3	#3/0 ~ 400 kcmil
			575	60	2	#2 - 600 kcmil	2	#1 ~ 500 kcmil	2	#1 ~ 500 kcmil
052	3	J	200	60						
			230	60						
			380	60	3	#2 - 600 kcmil	3	#3/0 ~ 400 kcmil	3	#3/0 ~ 400 kcmil
			400	50	3	#2 - 600 kcmil	3	#3/0 ~ 400 kcmil	3	#3/0 ~ 400 kcmil
			460	60	2	#2 - 600 kcmil	3	#3/0 ~ 400 kcmil	3	#3/0 ~ 400 kcmil
			575	60	2	#2 - 600 kcmil	2	#1 ~ 500 kcmil	2	#1 ~ 500 kcmil

4

FIELD WIRING LUGS					TERMINAL BLOCK	TERMINAL BLOCK WITH INDEPENDENT SYSTEM CIRCUIT BREAKERS	TERMINAL BLOCK WITH INDEPENDENT SYSTEM NON-FUSED DISCONNECT SWITCHES			
YVAA MODEL			INPUT VOLTS	INPUT FREQ	WIRES PER PHASE	LUG WIRE RANGE	WIRES PER PHASE	LUG WIRE RANGE	WIRES PER PHASE	LUG WIRE RANGE
FRAME	COND	EVAP								
SINGLE POINT WIRING										
Models 0368 to 0523			200	60						
			230	60						
			380	60	4	#1 - 750 kcmil	4	#1 - 750 kcmil	4	#1 - 750 kcmil
			400	50	4	#1 - 750 kcmil	4	#1 - 750 kcmil	4	#1 - 750 kcmil
			460	60	4	#1 - 750 kcmil	4	#1 - 750 kcmil	4	#1 - 750 kcmil
			575	60	4	#1 - 750 kcmil	4	#1 - 750 kcmil	4	#1 - 750 kcmil

THIS PAGE INTENTIONALLY LEFT BLANK

SECTION 5 - TECHNICAL DATA

NOMENCLATURE

YVAA 021 3AXX 46 AA														
1 2 3 4 BASE PRODUCT TYPE				5 6 7 FRAME SIZE			8 9 10 11 CONFIGURATION				12 13 VOLTAGE		14 15 LEVEL / REFRIGERANT	
Y	V	A	A	#	#	#	#	#	#	#	1	7	#	A
: York							: Condenser code				: 200 / 3 / 60		: Development Level	
: Variable Speed Screw							: Evaporator code				: 230 / 3 / 60		: Refrigerant R134a	
: Air cooled							: Compressor code				: 380 / 3 / 60			
: Design Series							: Condenser fan & sound kit code				: 400 / 3 / 60			
											: 460 / 3 / 60			
											: 380-415 / 3 / 50			
											: 575 / 3 / 60			

5



Products are produced at a facility whose quality-management systems are ISO9001 certified.



ASHRAE 90.1 Compliant



The data shown in this table is applicable to selected typical configurations. Other configurations are available through our configuration/selection software.

Please contact your nearest Johnson Controls Sales Office for the chiller configuration that best matches your specific needs.

TABLE 5 - PHYSICAL DATA - MICROCHANNEL COIL

UNIT FRAME	15	16	17	18	19	19	20	21	21
CONDENSER CODE	3	5	8	3	5	8	0	3	5
EVAPORATOR CODE	B	B	C	A	A	B	C	A	C
GENERAL UNIT DATA									
Number of Independent Refrigerant Circuits	2								
Refrigerant Charge, R-134a, Ckt.-1/Ckt.-2, lbs (kg)	175/175 (79/79)	190/190 (86/86)	225/225 (102/102)	175/155 (79/70)	190/170 (86/77)	220/195 (100/88)	205/205 (93/93)	175/175 (79/79)	225/225 (102/102)
Oil Charge, Ckt.-1/Ckt.-2, gal (liters)	2.1/2.0 (8.0/7.7)	2.2/2.2 (8.5/8.5)	2.5/2.5 (9.3/9.3)	2.4/2.0 (9.2/7.7)	2.6/2.1 (9.7/8.0)	2.7/2.2 (10.4/8.5)	2.6/2.6 (10.0/10.0)	2.5/2.5 (9.3/9.3)	2.8/2.8 (10.5/10.5)
Minimum Load (%)	10%								
Unit shipping weight, lbs (kg) 1	11518 (5224)	12084 (5481)	14668 (6653)	12019 (5452)	12781 (5797)	13776 (6248)	13392 (6074)	12859 (5833)	14915 (6765)
Operating Weight, lbs (kg) 1	11979 (5434)	12546 (5691)	15432 (7000)	12460 (5652)	13222 (5997)	14237 (6458)	14155 (6421)	13300 (6033)	15678 (7111)
Chassis Dimensions - Length, inches (mm)	203.3 (5163)	247.2 (6280)	291.2 (7397)	247 (6274)	291.2 (7397)	335.2 (8514)	226 (5741)	291.2 (7397)	291.2 (7397)
Chassis Dimensions - Width, inches (mm)	88.3 (2242)	88.3 (2242)	88.3 (2242)	88.3 (2242)	88.3 (2242)	88.3 (2242)	88.3 (2242)	88.3 (2242)	88.3 (2242)
Chassis Dimensions - Height, inches (mm)	94.6 (2403)	94.6 (2403)	94.6 (2403)	94.6 (2403)	94.6 (2403)	94.6 (2403)	94.6 (2403)	94.6 (2403)	94.6 (2403)
COMPRESSORS, SEMI-HERMETIC SCREW									
Qty per Chiller	2								
CONDENSER FANS									
Number Ckt-1/Ckt-2	4/4	5/5	6/6	6/4	7/5	8/6	4/4	6/6	6/6
Air on Condenser (Min/Max), °F (°C)	0/125 (-17.8/51.7)								
EVAPORATOR, SHELL AND TUBE HYBRID FALLING FILM ²									
Water Volume, gal (liters)	58 (220)	58 (220)	71 (269)	48 (182)	48 (182)	58 (220)	71 (269)	48 (182)	71 (269)
Leaving Water Temperature (Min/Max), °F (°C) 3	40/60 (4.4/15.6)								
Maximum Water Side Pressure, psig (barg)	150 (10.3)								
Maximum Refrigerant Side Pressure, psig (barg)	235 (16.2)								
Evap Drain Connection, inches (mm)	3/4								
Minimum Chilled Water Flow Rate, gpm (l/sec)	250 (15.8)	250 (15.8)	300 (18.9)	200 (12.6)	200 (12.6)	250 (15.8)	300 (18.9)	200 (12.6)	300 (18.9)
Maximum Chilled Water Flow Rate, gpm (l/sec)	950 (59.9)	950 (59.9)	1150 (72.6)	750 (47.3)	750 (47.3)	950 (59.9)	1150 (72.6)	750 (47.3)	1150 (72.6)
Inlet and Outlet Water Connections, in	6	6	6	6	6	6	6	6	6

NOTES:

- Shipping and operating weights shown are for base unit; selected options may add weight to unit. Contact your nearest Johnson Controls Sales office for weight data.
- For leaving liquid temperature below 40°F(4.4°C) or above 60°F (15.6°C), contact your nearest Johnson Controls Sales Office for application requirements.

TABLE 5 - PHYSICAL DATA - MICROCHANNEL COIL (CONT'D)

UNIT FRAME	21	23	24	24	26	27	27	27	29	30
CONDENSER CODE	8	3	5	8	3	3	5	8	5	3
EVAPORATOR CODE	C	B	C	C	B	D	E	E	E	C
GENERAL UNIT DATA										
Number of Independent Refrigerant Circuits	2									
Refrigerant Charge, R-134a, Ckt.-1/Ckt.-2, lbs (kg)	240/240 (109/109)	210/190 (95/86)	250/225 (113/102)	250/250 (113/113)	210/210 (95/95)	265/265 (120/120)	265/265 (120/120)	270/270 (122/122)	310/265 (141/120)	290/245 (132/111)
Oil Charge, Ckt.-1/Ckt.-2, gal (liters)	2.9/2.9 (10.8/ 10.8)	2.7/2.6 (10.1/ 9.7)	2.9/2.8 (11.1/ 10.5)	2.9/2.9 (11.1/ 11.1)	2.7/2.7 (10.1/ 10.1)	3.0/3.0 (11.4/ 11.4)	3.0/3.0 (11.4/ 11.4)	3.1/3.1 (11.6/ 11.6)	4.2/3.1 (15.9/ 11.7)	4.1/3.0 (15.5/ 11.4)
Minimum Load (%)	10%									
Unit shipping weight, lbs (kg) 1	15677 (7111)	13288 (6027)	15873 (7200)	16634 (7545)	14076 (6385)	16275 (7382)	16991 (7707)	17753 (8052)	18205 (8258)	17114 (7763)
Operating Weight, lbs (kg) 1	16440 (7457)	13750 (6237)	16636 (7546)	17398 (7891)	14538 (6594)	17103 (7758)	17851 (8097)	18612 (8442)	19065 (8648)	17877 (8109)
Chassis Dimensions - Length, inches (mm)	335.2 (8514)	291.2 (7397)	335.2 (8514)	379.1 (9631)	335.2 (8514)	335.2 (8514)	335.2 (8514)	379.2 (9631)	379.2 (9631)	379.2 (9631)
Chassis Dimensions - Width, inches (mm)	88.3 (2242)	88.3 (2242)	88.3 (2242)	88.3 (2242)	88.3 (2242)	88.3 (2242)	88.3 (2242)	88.3 (2242)	88.3 (2242)	88.3 (2242)
Chassis Dimensions - Height, inches (mm)	94.6 (2403)	94.6 (2403)	94.6 (2403)	94.6 (2403)	94.6 (2403)	94.6 (2403)	94.6 (2403)	94.6 (2403)	94.6 (2403)	94.6 (2403)
COMPRESSORS, SEMI-HERMETIC SCREW										
Qty per Chiller	2									
CONDENSER FANS										
Number Ckt-1/Ckt-2	7/7	7/5	8/6	8/8	7/7	7/7	7/7	8/8	9/7	9/7
Air on Condenser (Min/Max), °F (°C)	0/125									
EVAPORATOR, SHELL AND TUBE HYBRID FALLING FILM ²										
Water Volume, gal (liters)	71(269)	58(220)	71(269)	71(269)	58(220)	82(310)	113(428)	113(428)	113(428)	71(269)
Leaving Water Temperature (Min/Max), °F (°C) 3	40/60 (4.4/15.6)									
Maximum Water Side Pressure, psig (barg)	150 (10.3)									
Maximum Refrigerant Side Pressure, psig (barg)	235 (16.2)									
Evap Drain Connection, inches (mm)	3/4									
Minimum Chilled Water Flow Rate, gpm (l/sec)	300 (18.9)	250 (15.8)	300 (18.9)	300 (18.9)	250 (15.8)	300 (18.9)	400 (25.2)	400 (25.2)	400 (25.2)	300 (18.9)
Maximum Chilled Water Flow Rate, gpm (l/sec)	1150 (72.6)	950 (59.9)	1150 (72.6)	1150 (72.6)	950 (59.9)	1150 (72.6)	1500 (94.7)	1500 (94.7)	1500 (94.7)	1150 (72.6)
Inlet and Outlet Water Connections, in	6	6	6	6	6	6	8	8	8	6

NOTES:

- Shipping and operating weights shown are for base unit; selected options may add weight to unit. Contact your nearest Johnson Controls Sales office for weight data.
- For leaving liquid temperature below 40°F(4.4°C) or above 60°F (15.6°C), contact your nearest Johnson Controls Sales Office for application requirements.

TABLE 5 - PHYSICAL DATA - MICROCHANNEL COIL (CONT'D)

UNIT FRAME	30	30	31	32	33	34	34	36	37
CONDENSER CODE	5	8	8	3	3	3	5	8	3
EVAPORATOR CODE	C	E	E	E	C	E	E	J	F
GENERAL UNIT DATA									
Number of Independent Refrigerant Circuits	2								
Refrigerant Charge, R-134a, Ckt.-1/Ckt.-2, lbs (kg)	295/250 (134/114)	315/275 (143/125)	315/295 (143/134)	295/295 (134/134)	290/290 (132/132)	310/310 (141/141)	315/315 (143/143)	475/320 (216/145)	420/245 (191/111)
Oil Charge, Ckt.-1/Ckt.-2, gal (liters)	4.1/3.0 (15.5/ 11.4)	4.3/3.2 (16.3/ 12.1)	4.3/3.3 (16.3/ 12.5)	4.1/4.1 (15.5/ 15.5)	4.1/4.1 (15.5/ 15.5)	4.2/4.2 (15.9/ 15.9)	4.3/4.3 (16.3/ 16.3)	5.6/5.0 (21.2/ 19.0)	5.3/2.9 (20.1/ 11.0)
Minimum Load (%)	10%								
Unit shipping weight, lbs (kg) 1	17875 (8108)	18967 (8603)	19728 (8948)	18554 (8416)	18224 (8266)	19315 (8761)	20077 (9107)	24831 (11263)	22346 (10136)
Operating Weight, lbs (kg) 1	18638 (8454)	19827 (8993)	20588 (9339)	19414 (8806)	18987 (8612)	20175 (9151)	20937 (9497)	26188 (11879)	23405 (10616)
Chassis Dimensions - Length, inches (mm)	423.1 (10748)	423.1 (10748)	467.1 (11865)	379.2 (9631)	423.1 (10748)	423.1 (10748)	467.1 (11865)	511 (12979)	467.1 (11864)
Chassis Dimensions - Width, inches (mm)	88.3 (2242)	88.3 (2242)	88.3 (2242)	88.3 (2242)	88.3 (2242)	88.3 (2242)	88.3 (2242)	88.3 (2243)	88.3 (2243)
Chassis Dimensions - Height, inches (mm)	94.6 (2403)	94.6 (2403)	94.6 (2403)	94.6 (2403)	94.6 (2403)	94.6 (2403)	94.6 (2403)	94.7 (2405)	94.7 (2405)
COMPRESSORS, SEMI-HERMETIC SCREW									
Qty per Chiller	2								
CONDENSER FANS									
Number Ckt-1/Ckt-2	10/8	10/8	8/8	8/8	9/9	9/9	10/10	14/8	13/7
Air on Condenser (Min/Max), °F (°C)	0/125 (-17.8/51.7)								
EVAPORATOR, SHELL AND TUBE HYBRID FALLING FILM ²									
Water Volume, gal (liters)	71 (269)	113 (428)	113 (428)	113 (428)	71 (269)	113 (428)	113 (428)	147 (556)	96 (363)
Leaving Water Temperature (Min/Max), °F (°C) ²	40/60 (4.4/15.6)								
Maximum Water Side Pressure, psig (barg)	150 (10.3)								
Maximum Refrigerant Side Pressure, psig (barg)	235 (16.2)								
Evap Drain Connection, inches (mm)	3/4								
Minimum Chilled Water Flow Rate, gpm (l/sec)	300 (18.9)	400 (25.2)	400 (25.2)	400 (25.2)	300 (18.9)	400 (25.2)	400 (25.2)	550 (34.1)	460 (29.0)
Maximum Chilled Water Flow Rate, gpm (l/sec)	1150 (72.6)	1500 (94.7)	1500 (94.7)	1500 (94.7)	1150 (72.6)	1500 (94.7)	1500 (94.7)	1880 (118.1)	1540 (97.0)
Inlet and Outlet Water Connections, in	6	8	8	8	6	8	8	8	8

NOTES:

- Shipping and operating weights shown are for base unit; selected options may add weight to unit. Contact your nearest Johnson Controls Sales office for weight data.
- For leaving liquid temperature below 40°F(4.4°C) or above 60°F (15.6°C), contact your nearest Johnson Controls Sales Office for application requirements.

TABLE 5 - PHYSICAL DATA - MICROCHANNEL COIL (CONT'D)

UNIT FRAME	37	39	41	42	42	44	47	48	50	52
CONDENSER CODE	5	8	3	5	8	3	5	3	0	3
EVAPORATOR CODE	J	J	H	H	J	G	J	G	J	J
GENERAL UNIT DATA										
Number of Independent Refrigerant Circuits	2									
Refrigerant Charge, R-134a, Ckt.-1/Ckt.-2, lbs (kg)	470/310 (213/141)	475/360 (216/163)	460/345 (209/156)	480/365 (218/166)	475/385 (215/175)	370/370 (168/168)	445/445 (202/202)	385/385 (175/175)	405/405 (184/184)	445/445 (202/202)
Oil Charge, Ckt.-1/Ckt.-2, gal (liters)	5.6/4.3 (21.2/ 16.3)	5.6/5.1 (21.2/ 19.3)	5.5/4.3 (20.8/ 16.3)	5.6/4.4 (21.2/ 16.7)	5.6/5.1 (21.2/ 19.3)	5.0/5.0 (18.9/ 18.9)	5.4/5.4 (20.4/ 20.4)	5.1/5.1 (19.3/ 19.3)	5.2/5.2 (19.7/ 19.7)	5.4/5.4 (20.4/ 20.4)
Minimum Load (%)	10%									
Unit shipping weight, lbs (kg) 1	24070 (10918)	25941 (11767)	21242 (9635)	22765 (10326)	26703 (12112)	25942 (11767)	28427 (12894)	26704 (12113)	25968 (11779)	28427 (12894)
Operating Weight, lbs (kg) 1	25426 (11533)	27298 (12382)	22049 (10001)	23572 (10692)	28060 (12728)	27001 (12247)	29784 (13510)	27763 (12593)	27325 (12394)	29784 (13510)
Chassis Dimensions - Length, inches (mm)	467.1 (11864)	555.3 (14104)	467.1 (11864)	555.3 (14104)	599.3 (15222)	555.3 (14104)	599.3 (15222)	599.3 (15222)	467.1 (11865)	599.3 (15222)
Chassis Dimensions - Width, inches (mm)	88.3 (2243)	88.3 (2243)	88.3 (2243)	88.3 (2243)	88.3 (2243)	88.3 (2243)	88.3 (2243)	88.4 (2244)	88.3 (2243)	88.3 (2243)
Chassis Dimensions - Height, inches (mm)	94.7 (2405)	94.7 (2405)	94.7 (2405)	94.7 (2405)	94.7 (2405)	94.7 (2405)	94.7 (2405)	94.7 (2405)	94.7 (2405)	94.7 (2405)
COMPRESSORS, SEMI-HERMETIC SCREW										
Qty per Chiller	2									
CONDENSER FANS										
Number Ckt-1/Ckt-2	13/7	14/10	12/8	14/10	14/12	12/12	13/13	13/13	10/10	13/13
Air on Condenser (Min/Max), °F (°C)	0/125									
EVAPORATOR, SHELL AND TUBE HYBRID FALLING FILM ²										
Water Volume, gal (liters)	147(556)	147(556)	130(492)	130(492)	147(556)	96(363)	147(556)	96(363)	147(556)	147(556)
Leaving Water Temperature (Min/Max), °F (°C) ²	40/60 (4.4/15.6)									
Maximum Water Side Pressure, psig (barg)	150 (10.3)									
Maximum Refrigerant Side Pressure, psig (barg)	235 (16.2)									
Evap Drain Connection, inches (mm)	3/4									
Minimum Chilled Water Flow Rate, gpm (l/sec)	550 (34.1)	550 (34.1)	520 (33.0)	520 (33.0)	550 (34.1)	460 (29.0)	550 (34.1)	460 (29.0)	550 (34.1)	550 (34.1)
Maximum Chilled Water Flow Rate, gpm (l/sec)	1880 (118.1)	1880 (118.1)	1700 (107.0)	1700 (107.0)	1880 (118.1)	1540 (97.0)	1880 (118.1)	1540 (97.0)	1880 (118.1)	1880 (118.1)
Inlet and Outlet Water Connections, in	8	8	8	8	8	8	8	8	8	8

NOTES:

- Shipping and operating weights shown are for base unit; selected options may add weight to unit. Contact your nearest Johnson Controls Sales office for weight data.
- For leaving liquid temperature below 40°F(4.4°C) or above 60°F (15.6°C), contact your nearest Johnson Controls Sales Office for application requirements.

5

TABLE 6 - PHYSICAL DATA - ROUND TUBE COIL

UNIT FRAME	15	18	20	21	23	26	27	30
CONDENSER CODE	3	3	0	3	3	3	3	3
EVAPORATOR CODE	B	A	C	A	B	B	D	C
GENERAL UNIT DATA								
Number of Independent Refrigerant Circuits	2							
Refrigerant Charge, R-134a, Ckt.-1/Ckt.-2, lbs (kg)	211/211 (96/96)	229/191 (104/87)	241/241 (109/109)	229/229 (104/104)	273/235 (124/107)	273/273 (124/124)	328/328 (149/149)	371/308 (168/140)
Oil Charge, Ckt.-1/Ckt.-2, gal (liters)	2.1/2.0 (8.0/7.7)	2.4/2.0 (9.2/7.7)	2.6/2.6 (9.9/9.9)	2.5/2.5 (9.5/9.5)	2.7/2.6 (10.3/9.9)	2.7/2.7 (10.3/10.3)	3.0/3.0 (11.4/11.4)	4.1/3.0 (15.6/11.4)
Minimum Load (%)	10%							
Unit shipping weight, Round Tube cond coils, lbs (kg) ²	12354 (5604)	13064 (5926)	14228 (6454)	14113 (6402)	14542 (6596)	15539 (7048)	17738 (8046)	18786 (8521)
Unit shipping weight, Round Tube with Copper Fin cond coils, lbs (kg) ²	13674 (6202)	14714 (6674)	15548 (7052)	16093 (7300)	16522 (7494)	17849 (8096)	20048 (9094)	21426 (9719)
Operating Weight, Round Tube cond coils, lbs (kg) ²	12815 (5813)	13505 (6126)	14991 (6800)	14554 (6602)	15004 (6806)	16001 (7258)	18566 (8421)	19549 (8867)
Operating Weight, Round Tube with Copper Fin cond coils, lbs (kg) ²	14135 (6412)	15155 (6874)	16311 (7399)	16534 (7500)	16984 (7704)	18311 (8306)	20876 (9469)	22189 (10065)
Chassis Dimensions - Length, inches (mm)	203.3 (5163)	247 (6274)	226 (5740)	291.2 (7397)	291.2 (7397)	335.2 (8514)	335.2 (8514)	379.2 (9631)
Chassis Dimensions - Width, inches (mm)	88.3 (2242)	88.3 (2242)	88.3 (2242)	88.3 (2242)	88.3 (2242)	88.3 (2242)	88.3 (2242)	88.3 (2242)
Chassis Dimensions - Height, inches (mm)	94.6 (2403)	94.6 (2403)	94.6 (2403)	94.6 (2403)	94.6 (2403)	94.6 (2403)	94.6 (2403)	94.6 (2403)
COMPRESSORS, SEMI-HERMETIC SCREW								
Qty per Chiller	2							
CONDENSER FANS								
Number Ckt-1/Ckt-2	4/4	6/4	4/4	6/6	7/5	7/7	7/7	9/7
Air on Condenser (Min/Max), °F (°C)	0/125 (-17.8/51.7)							
EVAPORATOR, SHELL AND TUBE HYBRID FALLING FILM								
Water Volume, gal (liters)	58 (220)	48 (182)	71 (269)	48 (182)	58 (220)	58 (220)	82 (310)	71 (269)
Leaving Water Temperature (Min/Max), °F (°C) ²	40/60 (4.4/15.6)							
Maximum Water Side Pressure, psig (barg)	150 (10.3)							
Maximum Refrigerant Side Pressure, psig (barg)	235 (16.2)							
Evap Drain Connection, inches (mm)	3/4							
Minimum Chilled Water Flow Rate, gpm (l/sec)	250 (15.8)	200 (12.6)	300 (18.9)	200 (12.6)	250 (15.8)	250 (15.8)	300 (18.9)	300 (18.9)
Maximum Chilled Water Flow Rate, gpm (l/sec)	950 (59.9)	750 (47.3)	1150 (72.6)	750 (47.3)	950 (59.9)	950 (59.9)	1150 (72.6)	1150 (72.6)
Inlet and Outlet Water Connections, in	6	6	6	6	6	6	6	6

NOTES:

- Shipping and operating weights shown are for base unit; selected options may add weight to unit. Contact your nearest Johnson Controls Sales office for weight data.
- For leaving liquid temperature below 40°F(4.4°C) or above 60°F (15.6°C), contact your nearest Johnson Controls Sales Office for application requirements.

TABLE 6 - PHYSICAL DATA - ROUND TUBE COIL (CONT'D)

UNIT FRAME	32	33	34	37	41	44	48	50	52
CONDENSER CODE	3	3	3	3	3	3	3	0	3
EVAPORATOR CODE	E	C	E	F	H	G	G	J	J
GENERAL UNIT DATA									
Number of Independent Refrigerant Circuits	2								
Refrigerant Charge, R-134a, Ckt.-1/Ckt.-2, lbs (kg)	367/367 (166/166)	371/371 (168/168)	391/391 (177/177)	537/308 (244/140)	568/417 (258/189)	478/478 (217/217)	502/502 (228/228)	495/495 (224/224)	562/562 (255/255)
Oil Charge, Ckt.-1/Ckt.-2, gal (liters)	4.1/4.1 (15.6/ 15.6)	4.1/4.1 (15.6/ 15.6)	4.2/4.2 (15.9/ 15.9)	5.3/2.9 (20.0/ 11.0)	5.5/4.3 (20.8/ 16.3)	5.0/5.0 (18.9/ 18.9)	5.1/5.1 (19.3/ 19.3)	5.2/5.2 (19.5/ 19.5)	5.8/5.8 (22.0/ 22.0)
Minimum Load (%)	10%								
Unit shipping weight, Round Tube cond coils, lbs (kg) ²	20226 (9174)	20105 (9119)	21196 (9614)	24436 (11084)	23332 (10583)	28450 (12905)	29421 (13345)	28058 (12727)	31144 (14127)
Unit shipping weight, Round Tube with Copper Fin cond coils, lbs (kg) ²	22866 (10372)	23075 (10467)	24166 (10962)	27736 (12581)	26632 (12080)	32410 (14701)	33711 (15291)	31358 (14224)	35434 (16073)
Operating Weight, Round Tube cond coils, lbs (kg) ²	21086 (9564)	20868 (9466)	22056 (10004)	25495 (11564)	24139 (10949)	29509 (13385)	30480 (13825)	29415 (13342)	32501 (14742)
Operating Weight, Round Tube with Copper Fin cond coils, lbs (kg) ²	23726 (10762)	23838 (10813)	25026 (11352)	28795 (13061)	27439 (12446)	33469 (15181)	34770 (15771)	32715 (14839)	36791 (16688)
Chassis Dimensions - Length, inches (mm)	379.2 (9631)	423.1 (10748)	423.1 (10748)	467.1 (11864)	467.1 (11864)	555.3 (14104)	599.3 (15222)	467.1 (11864)	599.3 (15222)
Chassis Dimensions - Width, inches (mm)	88.3 (2242)	88.3 (2242)	88.3 (2242)	88.3 (2243)	88.3 (2243)	88.3 (2243)	88.4 (2244)	88.4 (2244)	88.3 (2243)
Chassis Dimensions - Height, inches (mm)	94.6 (2403)	94.6 (2403)	94.6 (2403)	94.7 (2405)	94.7 (2405)	94.7 (2405)	94.7 (2405)	94.7 (2405)	94.7 (2405)
COMPRESSORS, SEMI-HERMETIC SCREW									
Qty per Chiller	2								
CONDENSER FANS									
Number Ckt-1/Ckt-2	8/8	9/9	9/9	13/7	12/8	12/12	13/13	10/10	13/13
Air on Condenser (Min/Max), °F (°C)	0/125 (-17.8/51.7)								
EVAPORATOR, SHELL AND TUBE HYBRID FALLING FILM									
Water Volume, gal (liters)	113 (428)	71 (269)	113 (428)	96 (363)	130 (492)	96 (363)	96 (363)	147 (556)	147 (556)
Leaving Water Temperature (Min/Max), °F (°C) ²	40/60 (4.4/15.6)								
Maximum Water Side Pressure, psig (barg)	150 (10.3)								
Maximum Refrigerant Side Pressure, psig (barg)	235 (16.2)								
Evap Drain Connection, inches (mm)	3/4								
Minimum Chilled Water Flow Rate, gpm (l/sec)	400 (25.2)	300 (18.9)	400 (25.2)	460 (29.0)	520 (33.0)	460 (29.0)	460 (29.0)	550 (34.1)	550 (34.1)
Maximum Chilled Water Flow Rate, gpm (l/sec)	1500 (94.7)	1150 (72.6)	1500 (94.7)	1540 (97.0)	1700 (107.0)	1540 (97.0)	1540 (97.0)	1880 (118.1)	1880 (118.1)
Inlet and Outlet Water Connections, in	8	6	8	8	8	8	8	8	8

NOTES:

- Shipping and operating weights shown are for base unit; selected options may add weight to unit. Contact your nearest Johnson Controls Sales office for weight data.
- For leaving liquid temperature below 40°F(4.4°C) or above 60°F (15.6°C), contact your nearest Johnson Controls Sales Office for application requirements.

The data below is applicable to select configurations. Other configurations are available through our configuration/selection software. Please contact your nearest Johnson Controls Sales Office for the chiller configuration that best matches your specific needs.

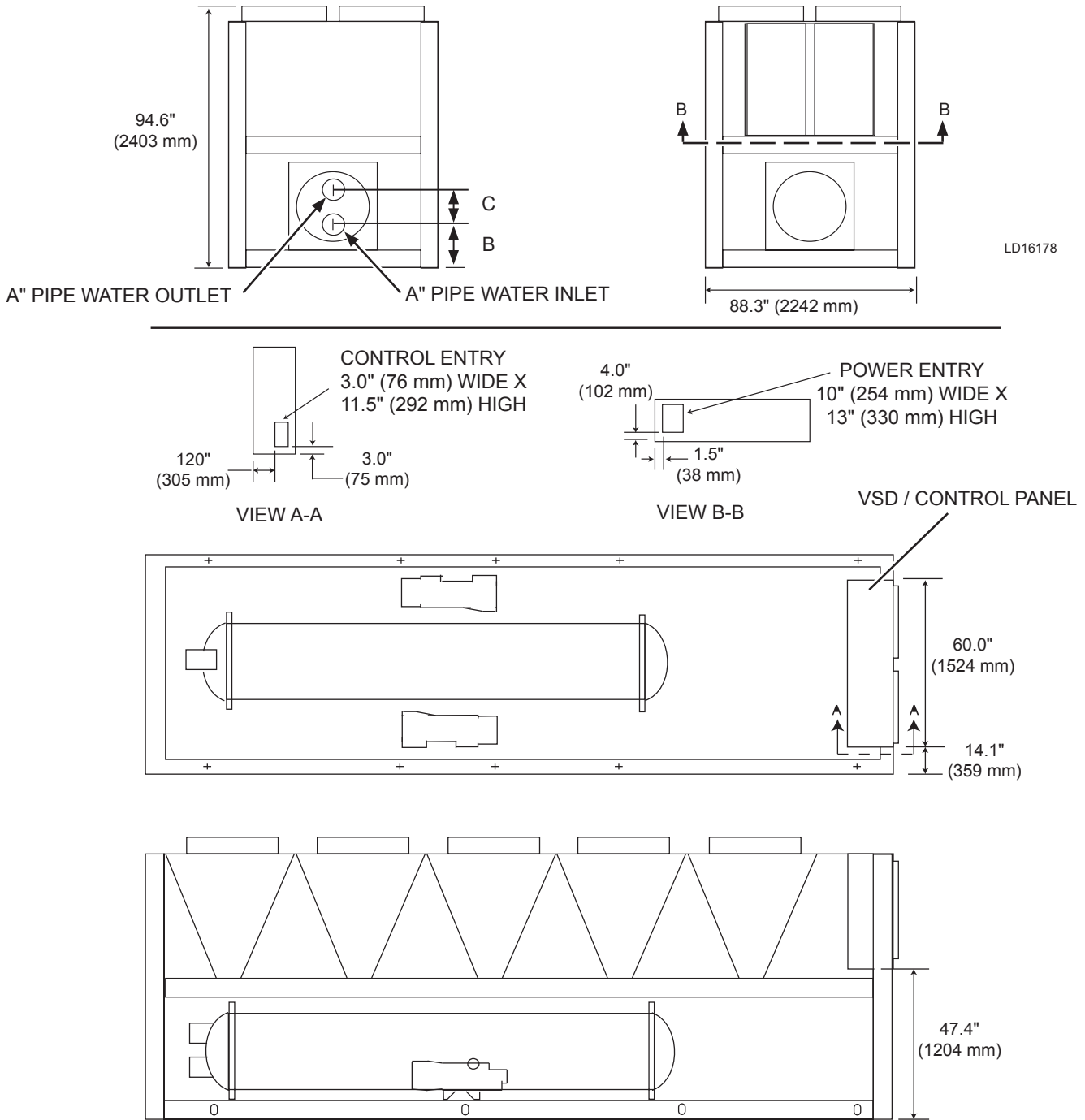

FIGURE 15 - YVAA DIMENSIONS

THIS PAGE INTENTIONALLY LEFT BLANK

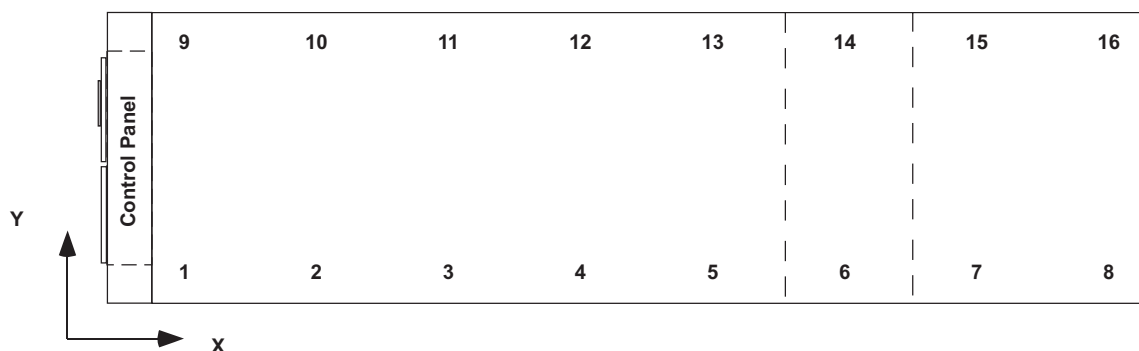

TABLE 7 - ISOLATOR SELECTION AND MOUNTING LOCATIONS

YVAA CONFIGURATION			DESCRIPTION	1	2	3	4	5	6	7	8
FRAME	COND	EVAP									
015	3	B	Isolator X-Dimension	10 (263)	73 (1852)	144 (3662)	193 (4900)				
			Isolator Y-Dimension	1 (34)							
			Point Load ¹	1055 (479)	2150 (975)	2150 (975)	635 (288)				
016	5	B	Isolator X-Dimension	10 (263)	77 (1943)	118 (3000)	157 (3985)	220 (5589)			
			Isolator Y-Dimension	1 (34)							
			Point Load ¹	883 (401)	764 (347)	1788 (811)	1788 (811)	1048 (475)			
017	8	C	Isolator X-Dimension	10 (263)	81 (2057)	149 (3779)	187 (4756)	251 (6368)			
			Isolator Y-Dimension	1 (34)							
			Point Load ¹	734 (333)	2308 (1047)	1598 (725)	1598 (725)	1477 (670)			
018	3	A	Isolator X-Dimension	10 (263)	76 (1943)	124 (3152)	163 (4137)	210 (5323)			
			Isolator Y-Dimension	1 (34)							
			Point Load ¹	714 (324)	1658 (752)	1089 (494)	1089 (494)	1655 (751)			
019	5	A	Isolator X-Dimension	10 (259)	76 (1939)	118 (2997)	157 (3982)	208 (5295)	281 (7132)		
			Isolator Y-Dimension	1 (34)							
			Point Load ¹	851 (386)	851 (386)	1315 (596)	2167 (983)	701 (318)	701 (318)		
019	8	B	Isolator X-Dimension	10 (263)	76 (1943)	118 (3000)	157 (3985)	209 (5299)	308 (7823)		
			Isolator Y-Dimension	1 (34)							
			Point Load ¹	620 (281)	2105 (955)	664 (301)	664 (301)	2438 (1106)	603 (274)		
020	0	C	Isolator X-Dimension	10 (263)	76 (1943)	118 (3000)	157 (3985)	209 (5299)	281 (7136)		
			Isolator Y-Dimension	1 (34)							
			Point Load ¹	853 (387)	853 (387)	1324 (601)	2202 (999)	709 (322)	709 (322)		
021	3	A	Isolator X-Dimension	10 (263)	81 (2057)	149 (3779)	187 (4756)	251 (6368)			
			Isolator Y-Dimension	1 (34)							
			Point Load ¹	661 (300)	2075 (941)	1706 (774)	1706 (774)	1692 (767)			

NOTES:

1. Microchannel condenser coils only
2. Operating weight shown is for base unit (460/3/60, no options); selected options may add weight to unit. Contact your nearest Johnson Controls Sales Office for weight data.
3. All isolator mounting holes are 19mm.
4. Dimensions are in inches (mm) and weights are in pounds (kg)



TABLE 7 - ISOLATOR SELECTION AND MOUNTING LOCATIONS (CONT'D)

YVAA CONFIGURATION			DESCRIPTION	9	10	11	12	13	14	15	16		
FRAME	COND	EVAP											
015	3	B	Isolator X-Dimension	10 (263)	73 (1852)	144 (3662)	193 (4900)						
			Isolator Y-Dimension	87 (2206)									
			Point Load ¹	981 (445)	2119 (961)	2119 (961)	771 (350)						
016	5	B	Isolator X-Dimension	10 (263)	77 (1943)	118 (3000)	157 (3985)	220 (5589)					
			Isolator Y-Dimension	87 (2206)									
			Point Load ¹	865 (392)	736 (334)	1786 (810)	1786 (810)	1100 (499)					
017	8	C	Isolator X-Dimension	10 (263)	81 (2057)	149 (3779)	187 (4756)	251 (6368)					
			Isolator Y-Dimension	87 (2206)									
			Point Load ¹	726 (329)	2201 (998)	1616 (733)	1616 (733)	1557 (706)					
018	3	A	Isolator X-Dimension	10 (263)	76 (1943)	124 (3152)	163 (4137)	210 (5323)					
			Isolator Y-Dimension	87 (2206)									
			Point Load ¹	708 (321)	1652 (749)	1085 (492)	1085 (492)	1725 (782)					
019	5	A	Isolator X-Dimension	10 (259)	76 (1939)	118 (2997)	157 (3982)	208 (5295)	281 (7132)				
			Isolator Y-Dimension	87 (2206)									
			Point Load ¹	845 (383)	845 (383)	1289 (585)	2224 (1009)	717 (325)	717 (325)				
019	8	B	Isolator X-Dimension	10 (263)	76 (1943)	118 (3000)	157 (3985)	209 (5299)	308 (7823)				
			Isolator Y-Dimension	87 (2206)									
			Point Load ¹	600 (272)	2121 (962)	655 (297)	655 (297)	2511 (1139)	603 (274)				
020	0	C	Isolator X-Dimension	10 (263)	76 (1943)	118 (3000)	157 (3985)	209 (5299)	281 (7136)				
			Isolator Y-Dimension	87 (2206)									
			Point Load ¹	847 (384)	847 (384)	1293 (586)	2228 (1011)	717 (325)	717 (325)				
021	3	A	Isolator X-Dimension	10 (263)	81 (2057)	149 (3779)	187 (4756)	251 (6368)					
			Isolator Y-Dimension	87 (2206)									
			Point Load ¹	655 (297)	1990 (903)	1711 (776)	1711 (776)	1771 (803)					

NOTES:

1. Microchannel condenser coils only
2. Operating weight shown is for base unit (460/3/60, no options); selected options may add weight to unit. Contact your nearest Johnson Controls Sales Office for weight data.
3. All isolator mounting holes are 19mm.
4. Dimensions are in inches (mm) and weights are in pounds (kg)

TABLE 7 - ISOLATOR SELECTION AND MOUNTING LOCATIONS (CONT'D)

YVAA CONFIGURATION			DESCRIPTION	1	2	3	4	5	6	7	8	
FRAME	COND	EVAP										
021	5	C	Isolator X-Dimension	10 (263)	81 (2057)	149 (3779)	187 (4756)	235 (5968)	301 (7653)			
			Isolator Y-Dimension	1 (34)								
			Point Load ¹	717 (325)	2727 (1237)	564 (256)	564 (256)	2431 (1103)	1216 (552)			
021	8	C	Isolator X-Dimension	10 (263)	76 (1943)	118 (2999)	157 (3984)	209 (5298)	281 (7135)			
			Isolator Y-Dimension	1 (34)								
			Point Load ¹	950 (431)	950 (431)	1426 (647)	2226 (1010)	658 (298)	658 (298)			
023	3	B	Isolator X-Dimension	10 (263)	76 (1943)	128 (3260)	173 (4391)	220 (5579)	301 (7654)			
			Isolator Y-Dimension	1 (34)								
			Point Load ¹	813 (369)	1915 (869)	1459 (662)	1459 (662)	1775 (805)	887 (402)			
024	5	C	Isolator X-Dimension	10 (263)	81 (2057)	143 (3638)	187 (4748)	245 (6232)	339 (8609)			
			Isolator Y-Dimension	1 (34)								
			Point Load ¹	663 (301)	1795 (814)	2030 (921)	2030 (921)	1086 (493)	1086 (493)			
024	8	C	Isolator X-Dimension	10 (263)	76 (1943)	118 (2999)	157 (3984)	209 (5298)	308 (7823)			
			Isolator Y-Dimension	1 (34)								
			Point Load ¹	699 (317)	2111 (958)	694 (315)	694 (315)	2468 (1119)	604 (274)			
026	3	B	Isolator X-Dimension	10 (263)	81 (2057)	161 (4084)	201 (5105)	301 (7654)				
			Isolator Y-Dimension	1 (34)								
			Point Load ¹	712 (323)	1544 (700)	2775 (1259)	2134 (968)	1387 (629)				
027	3	D	Isolator X-Dimension	10 (263)	81 (2057)	161 (4084)	201 (5105)	301 (7654)				
			Isolator Y-Dimension	1 (34)								
			Point Load ¹	691 (313)	1646 (747)	2871 (1302)	2282 (1035)	1435 (651)				
027	5	E	Isolator X-Dimension	10 (263)	81 (2057)	161 (4084)	201 (5105)	298 (7582)	339 (8609)			
			Isolator Y-Dimension	1 (34)								
			Point Load ¹	652 (296)	1773 (804)	2533 (1149)	2533 (1149)	907 (411)	907 (411)			
027	8	E	Isolator X-Dimension	10 (263)	81 (2057)	161 (4095)	201 (5105)	296 (7512)	339 (8609)			
			Isolator Y-Dimension	1 (34)								
			Point Load ¹	693 (314)	1821 (826)	2532 (1148)	2532 (1148)	919 (417)	919 (417)			
029	5	E	Isolator X-Dimension	10 (263)	81 (2057)	143 (3638)	187 (4748)	245 (6232)	339 (8609)			
			Isolator Y-Dimension	1 (34)								
			Point Load ¹	711 (323)	1804 (818)	2071 (939)	2071 (939)	1083 (491)	1083 (491)			

NOTES:

1. Microchannel condenser coils only
2. Operating weight shown is for base unit (460/3/60, no options); selected options may add weight to unit. Contact your nearest Johnson Controls Sales Office for weight data.
3. All isolator mounting holes are 19mm.
4. Dimensions are in inches (mm) and weights are in pounds (kg)

TABLE 7 - ISOLATOR SELECTION AND MOUNTING LOCATIONS (CONT'D)

YVAA CONFIGURATION			DESCRIPTION	9	10	11	12	13	14	15	16	
FRAME	COND	EVAP										
021	5	C	Isolator X-Dimension	10 (263)	81 (2057)	149 (3779)	187 (4756)	235 (5968)	301 (7653)			
			Isolator Y-Dimension	87 (2206)								
			Point Load ¹	704 (319)	2650 (1202)	571 (259)	571 (259)	2482 (1126)	1241 (563)			
021	8	C	Isolator X-Dimension	10 (263)	76 (1943)	118 (2999)	157 (3984)	209 (5298)	281 (7135)			
			Isolator Y-Dimension	87 (2206)								
			Point Load ¹	936 (425)	936 (425)	1433 (650)	2243 (1017)	669 (303)	669 (303)			
023	3	B	Isolator X-Dimension	10 (263)	76 (1943)	128 (3260)	173 (4391)	220 (5579)	301 (7654)			
			Isolator Y-Dimension	87 (2206)								
			Point Load ¹	807 (366)	1825 (828)	1482 (672)	1482 (672)	1821 (826)	910 (413)			
024	5	C	Isolator X-Dimension	10 (263)	81 (2057)	143 (3638)	187 (4748)	245 (6232)	339 (8609)			
			Isolator Y-Dimension	87 (2206)								
			Point Load ¹	663 (301)	1646 (747)	2097 (951)	2097 (951)	1102 (500)	1102 (500)			
024	8	C	Isolator X-Dimension	10 (263)	76 (1943)	118 (2999)	157 (3984)	209 (5298)	308 (7823)			
			Isolator Y-Dimension	87 (2206)								
			Point Load ¹	680 (308)	2126 (964)	671 (304)	671 (304)	2518 (1142)	604 (274)			
026	3	B	Isolator X-Dimension	10 (263)	81 (2057)	161 (4084)	201 (5105)	301 (7654)				
			Isolator Y-Dimension	87 (2206)								
			Point Load ¹	682 (309)	1377 (625)	3032 (1375)	1944 (882)	1516 (688)				
027	3	D	Isolator X-Dimension	10 (263)	81 (2057)	161 (4084)	201 (5105)	301 (7654)				
			Isolator Y-Dimension	87 (2206)								
			Point Load ¹	662 (300)	1480 (671)	3128 (1419)	2092 (949)	1564 (709)				
027	5	E	Isolator X-Dimension	10 (263)	81 (2057)	161 (4084)	201 (5105)	298 (7582)	339 (8609)			
			Isolator Y-Dimension	87 (2206)								
			Point Load ¹	598 (271)	1733 (786)	2527 (1146)	2527 (1146)	961 (436)	961 (436)			
027	8	E	Isolator X-Dimension	10 (263)	81 (2057)	161 (4095)	201 (5105)	296 (7512)	339 (8609)			
			Isolator Y-Dimension	87 (2206)								
			Point Load ¹	629 (285)	1830 (830)	2621 (1189)	2621 (1189)	973 (441)	973 (441)			
029	5	E	Isolator X-Dimension	10 (259)	81 (2055)	143 (3635)	187 (4745)	245 (6228)	339 (8606)			
			Isolator Y-Dimension	87 (2206)								
			Point Load ¹	711 (323)	1668 (757)	2245 (1018)	2245 (1018)	1092 (495)	1092 (495)			

NOTES:

1. Microchannel condenser coils only
2. Operating weight shown is for base unit (460/3/60, no options); selected options may add weight to unit. Contact your nearest Johnson Controls Sales Office for weight data.
3. All isolator mounting holes are 19mm.
4. Dimensions are in inches (mm) and weights are in pounds (kg)

TABLE 7 - ISOLATOR SELECTION AND MOUNTING LOCATIONS (CONT'D)

YVAA CONFIGURATION			DESCRIPTION	1	2	3	4	5	6	7	8	
FRAME	COND	EVAP										
030	3	C	Isolator X-Dimension	10 (263)	81 (2057)	144 (3663)	187 (4755)	277 (7047)	383 (9726)			
			Isolator Y-Dimension	1 (34)								
			Point Load ¹	870 (395)	1451 (658)	2185 (991)	2185 (991)	1652 (749)	861 (391)			
030	5	C	Isolator X-Dimension	10 (260)	81 (2054)	161 (4081)	201 (5102)	298 (7579)	383 (9723)			
			Isolator Y-Dimension	1 (34)								
			Point Load ¹	800 (363)	2001 (908)	2138 (970)	2138 (970)	1857 (842)	863 (391)			
030	8	E	Isolator X-Dimension	10 (263)	81 (2057)	161 (4084)	201 (5105)	298 (7582)	427 (10843)			
			Isolator Y-Dimension	1 (34)								
			Point Load ¹	788 (357)	2032 (922)	2067 (938)	2067 (938)	2211 (1003)	1013 (459)			
031	8	E	Isolator X-Dimension	10 (263)	81 (2057)	161 (4084)	201 (5105)	298 (7582)	339 (8609)			
			Isolator Y-Dimension	1 (34)								
			Point Load ¹	702 (318)	1771 (803)	2699 (1224)	2699 (1224)	918 (416)	918 (416)			
032	3	E	Isolator X-Dimension	10 (263)	81 (2057)	143 (3636)	188 (4781)	245 (6232)	383 (9726)			
			Isolator Y-Dimension	1 (34)								
			Point Load ¹	575 (261)	2930 (1329)	891 (404)	891 (404)	3346 (1518)	861 (391)			
033	3	C	Isolator X-Dimension	10 (260)	81 (2054)	161 (4081)	201 (5102)	298 (7579)	383 (9723)			
			Isolator Y-Dimension	1 (34)								
			Point Load ¹	801 (363)	1996 (905)	2260 (1025)	2260 (1025)	1909 (866)	863 (391)			
034	3	E	Isolator X-Dimension	10 (263)	81 (2057)	161 (4084)	201 (5105)	298 (7582)	427 (10843)			
			Isolator Y-Dimension	1 (34)								
			Point Load ¹	789 (358)	2027 (919)	2188 (992)	2188 (992)	2263 (1026)	1013 (459)			
034	5	E	Isolator X-Dimension	10 (263)	81 (2057)	161 (2908)	201 (5219)	298 (7218)	427 (10843)			
			Isolator Y-Dimension	1 (34)								
			Point Load ¹	789 (355)	2027 (1188)	2188 (1403)	2188 (1403)	2263 (1388)	1013 (460)			

NOTES:

1. Microchannel condenser coils only
2. Operating weight shown is for base unit (460/3/60, no options); selected options may add weight to unit. Contact your nearest Johnson Controls Sales Office for weight data.
3. All isolator mounting holes are 19mm.
4. Dimensions are in inches (mm) and weights are in pounds (kg)

TABLE 7 - ISOLATOR SELECTION AND MOUNTING LOCATIONS (CONT'D)

YVAA CONFIGURATION			DESCRIPTION	9	10	11	12	13	14	15	16
FRAME	COND	EVAP									
030	3	C	Isolator X-Dimension	10 (263)	81 (2057)	144 (3663)	187 (4755)	277 (7047)	383 (9726)		
			Isolator Y-Dimension	87 (2206)							
			Point Load ¹	765 (347)	1551 (704)	2240 (1016)	2240 (1016)	1779 (807)	861 (391)		
030	5	C	Isolator X-Dimension	10 (260)	81 (2054)	161 (4081)	201 (5102)	298 (7579)	383 (9723)		
			Isolator Y-Dimension	87 (2206)							
			Point Load ¹	789 (358)	1968 (893)	2235 (1014)	2235 (1014)	1938 (879)	863 (391)		
030	8	E	Isolator X-Dimension	10 (263)	81 (2057)	161 (4084)	201 (5105)	298 (7582)	427 (10843)		
			Isolator Y-Dimension	87 (2206)							
			Point Load ¹	778 (353)	1999 (907)	2164 (982)	2164 (982)	2292 (1040)	1013 (459)		
031	8	E	Isolator X-Dimension	10 (263)	81 (2057)	161 (4084)	201 (5105)	298 (7582)	339 (8609)		
			Isolator Y-Dimension	87 (2206)							
			Point Load ¹	635 (288)	1794 (814)	2675 (1213)	2675 (1213)	963 (437)	963 (437)		
032	3	E	Isolator X-Dimension	10 (263)	81 (2057)	143 (3636)	188 (4781)	245 (6232)	383 (9726)		
			Isolator Y-Dimension	87 (2206)							
			Point Load ¹	441 (200)	3177 (1441)	707 (321)	707 (321)	3601 (1633)	861 (391)		
033	3	C	Isolator X-Dimension	10 (260)	81 (2054)	161 (4081)	201 (5102)	298 (7579)	383 (9723)		
			Isolator Y-Dimension	87 (2206)							
			Point Load ¹	789 (358)	1967 (892)	2259 (1025)	2259 (1025)	1951 (885)	863 (391)		
034	3	E	Isolator X-Dimension	10 (263)	81 (2057)	161 (4084)	201 (5105)	298 (7582)	427 (10843)		
			Isolator Y-Dimension	87 (2206)							
			Point Load ¹	778 (353)	1998 (906)	2187 (992)	2187 (992)	2305 (1046)	1013 (459)		
034	5	E	Isolator X-Dimension	10 (263)	81 (2057)	161 (2908)	201 (5219)	298 (7218)	427 (10843)		
			Isolator Y-Dimension	87 (2206)							
			Point Load ¹	778 (349)	1998 (1179)	2187 (1398)	2187 (1398)	2305 (1412)	1013 (460)		

NOTES:

1. Microchannel condenser coils only
2. Operating weight shown is for base unit (460/3/60, no options); selected options may add weight to unit. Contact your nearest Johnson Controls Sales Office for weight data.
3. All isolator mounting holes are 19mm.
4. Dimensions are in inches (mm) and weights are in pounds (kg)

5

TABLE 7 - ISOLATOR SELECTION AND MOUNTING LOCATIONS (CONT'D)

YVAA CONFIGURATION			DESCRIPTION	1	2	3	4	5	6	7	8	
FRAME	COND	EVAP										
036	8	J	Isolator X-Dimension	10 (254)	81 (2057)	145 (3683)	205 (5207)	284 (7214)	383 (9728)	439 (11151)	495 (12573)	
			Isolator Y-Dimension	1 (34)								
			Point Load ¹	710 (322)	1869 (848)	2719 (1233)	2719 (1233)	2969 (1347)	250 (113)	742 (337)	416 (189)	
037	3	F	Isolator X-Dimension	10 (263)	81 (2057)	145 (3680)	206 (5219)	284 (7218)	427 (10842)			
			Isolator Y-Dimension	1 (34)								
			Point Load ¹	397 (180)	2636 (1196)	1895 (860)	1895 (860)	3216 (1459)	964 (437)			
037	5	J	Isolator X-Dimension	10 (263)	81 (2057)	145 (3680)	206 (5219)	284 (7218)	427 (10842)			
			Isolator Y-Dimension	1 (34)								
			Point Load ¹	397 (180)	2636 (1196)	1895 (860)	1895 (860)	3216 (1459)	964 (437)			
039	8	J	Isolator X-Dimension	10 (254)	81 (2057)	154 (3912)	206 (5232)	284 (7214)	427 (10846)	483 (12268)	539 (13691)	
			Isolator Y-Dimension	1 (34)								
			Point Load ¹	572 (259)	2139 (970)	2845 (1291)	2845 (1291)	2859 (1297)	897 (407)	478 (217)	429 (195)	
041	3	H	Isolator X-Dimension	10 (263)	81 (2057)	145 (3680)	205 (5219)	284 (7218)	427 (10843)			
			Isolator Y-Dimension	1 (34)								
			Point Load ¹	496 (225)	2869 (1301)	1386 (629)	1386 (629)	3339 (1515)	964 (437)			
042	5	H	Isolator X-Dimension	10 (254)	81 (2057)	154 (3907)	206 (5219)	284 (7214)	427 (10846)	483 (12243)	539 (13691)	
			Isolator Y-Dimension	1 (34)								
			Point Load ¹	622 (282)	1876 (851)	2207 (1001)	2207 (1001)	2486 (1127)	897 (407)	478 (217)	429 (195)	
042	8	J	Isolator X-Dimension	10 (254)	81 (2057)	145 (3683)	205 (5207)	284 (7214)	427 (10846)	505 (12827)	562 (14275)	
			Isolator Y-Dimension	1 (34)								
			Point Load ¹	556 (252)	2460 (1116)	2572 (1167)	2572 (1167)	3003 (1362)	1138 (516)	382 (173)	761 (345)	

NOTES:

1. Microchannel condenser coils only
2. Operating weight shown is for base unit (460/3/60, no options); selected options may add weight to unit. Contact your nearest Johnson Controls Sales Office for weight data.
3. All isolator mounting holes are 19mm.
4. Dimensions are in inches (mm) and weights are in pounds (kg)

TABLE 7 - ISOLATOR SELECTION AND MOUNTING LOCATIONS (CONT'D)

YVAA CONFIGURATION			DESCRIPTION	9	10	11	12	13	14	15	16	
FRAME	COND	EVAP										
036	8	J	Isolator X-Dimension	10 (254)	81 (2057)	145 (3683)	205 (5207)	284 (7214)	383 (9728)	439 (11151)	495 (12573)	
			Isolator Y-Dimension	87 (2206)								
			Point Load ¹	688 (312)	1826 (828)	3312 (1502)	3312 (1502)	3358 (1523)	46 (21)	839 (381)	413 (187)	
037	3	F	Isolator X-Dimension	10 (263)	81 (2057)	145 (3680)	206 (5219)	284 (7218)	427 (10842)			
			Isolator Y-Dimension	87 (2206)								
			Point Load ¹	404 (183)	2486 (1128)	2575 (1168)	2575 (1168)	3399 (1542)	964 (437)			
037	5	J	Isolator X-Dimension	10 (263)	81 (2057)	145 (3680)	206 (5219)	284 (7218)	427 (10842)			
			Isolator Y-Dimension	87 (2206)								
			Point Load ¹	404 (183)	2486 (1128)	2575 (1168)	2575 (1168)	3399 (1542)	964 (437)			
039	8	J	Isolator X-Dimension	10 (254)	81 (2057)	154 (3912)	206 (5232)	284 (7214)	427 (10846)	483 (12268)	539 (13691)	
			Isolator Y-Dimension	87 (2206)								
			Point Load ¹	547 (248)	2103 (954)	3399 (1542)	3399 (1542)	2982 (1352)	897 (407)	478 (217)	429 (195)	
041	3	H	Isolator X-Dimension	10 (263)	81 (2057)	145 (3680)	205 (5219)	284 (7218)	427 (10843)			
			Isolator Y-Dimension	87 (2206)								
			Point Load ¹	513 (233)	2709 (1229)	1981 (899)	1981 (899)	3462 (1570)	964 (437)			
042	5	H	Isolator X-Dimension	10 (254)	81 (2057)	154 (3683)	206 (5207)	284 (7214)	427 (10846)	483 (12243)	539 (13691)	
			Isolator Y-Dimension	87 (2206)								
			Point Load ¹	598 (271)	1840 (835)	2760 (1252)	2760 (1252)	2608 (1183)	897 (407)	478 (217)	429 (195)	
042	8	J	Isolator X-Dimension	10 (254)	81 (2057)	145 (3683)	205 (5207)	284 (7214)	427 (10846)	505 (12827)	562 (14275)	
			Isolator Y-Dimension	87 (2206)								
			Point Load ¹	659 (299)	2289 (1038)	3083 (1399)	3083 (1399)	3224 (1463)	1132 (513)	382 (173)	761 (345)	

5

NOTES:

1. Microchannel condenser coils only
2. Operating weight shown is for base unit (460/3/60, no options); selected options may add weight to unit. Contact your nearest Johnson Controls Sales Office for weight data.
3. All isolator mounting holes are 19mm.
4. Dimensions are in inches (mm) and weights are in pounds (kg)

TABLE 7 - ISOLATOR SELECTION AND MOUNTING LOCATIONS (CONT'D)

YVAA CONFIGURATION			DESCRIPTION	1	2	3	4	5	6	7	8	
FRAME	COND	EVAP										
044	3	G	Isolator X-Dimension	10 (263)	81 (2057)	154 (3907)	206 (5219)	284 (7218)	427 (10842)	483 (12274)	539 (13694)	
			Isolator Y-Dimension	1 (34)								
			Point Load ¹	676 (307)	2216 (1005)	3190 (1447)	3190 (1447)	2366 (1073)	976 (443)	452 (205)	436 (198)	
047	5	J	Isolator X-Dimension	10 (263)	81 (2057)	154 (3907)	206 (5219)	284 (7218)	427 (10842)	505 (12820)	562 (14265)	
			Isolator Y-Dimension	1 (34)								
			Point Load ¹	787 (357)	2418 (1097)	3310 (1501)	3310 (1501)	2720 (1234)	1202 (545)	386 (175)	759 (344)	
048	3	G	Isolator X-Dimension	10 (263)	81 (2057)	154 (3907)	206 (5219)	284 (7218)	427 (10842)	505 (12820)	562 (14265)	
			Isolator Y-Dimension	1 (34)								
			Point Load ¹	686 (311)	2160 (980)	3224 (1462)	3224 (1462)	2240 (1016)	1202 (545)	386 (175)	759 (344)	
050	0	J	Isolator X-Dimension	10 (263)	81 (2057)	154 (2908)	205 (5219)	284 (7218)	427 (10843)			
			Isolator Y-Dimension	1 (34)								
			Point Load ¹	783 (355)	2619 (1188)	3093 (1403)	3093 (1403)	3061 (1388)	1014 (460)			
052	3	J	Isolator X-Dimension	10 (263)	81 (2057)	154 (3907)	206 (5219)	284 (7218)	427 (10842)	505 (12820)	562 (14265)	
			Isolator Y-Dimension	1 (34)								
			Point Load ¹	794 (360)	2611 (1184)	3112 (1412)	3112 (1412)	2916 (1323)	1202 (545)	386 (175)	759 (344)	

NOTES:

1. Microchannel condenser coils only
2. Operating weight shown is for base unit (460/3/60, no options); selected options may add weight to unit. Contact your nearest Johnson Controls Sales Office for weight data.
3. All isolator mounting holes are 19mm.
4. Dimensions are in inches (mm) and weights are in pounds (kg)

TABLE 7 - ISOLATOR SELECTION AND MOUNTING LOCATIONS (CONT'D)

YVAA CONFIGURATION			DESCRIPTION	9	10	11	12	13	14	15	16	
FRAME	COND	EVAP										
044	3	G	Isolator X-Dimension	10 (263)	81 (2057)	154 (3907)	206 (5219)	284 (7218)	427 (10842)	483 (12274)	539 (13694)	
			Isolator Y-Dimension	87 (2206)								
			Point Load ¹	657 (298)	2147 (974)	3182 (1443)	3182 (1443)	2469 (1120)	976 (443)	452 (205)	436 (198)	
047	5	J	Isolator X-Dimension	10 (263)	81 (2057)	154 (3907)	206 (5219)	284 (7218)	427 (10842)	505 (12820)	562 (14265)	
			Isolator Y-Dimension	87 (2206)								
			Point Load ¹	765 (347)	2357 (1069)	3297 (1495)	3297 (1495)	2830 (1284)	1202 (545)	386 (175)	759 (344)	
048	3	G	Isolator X-Dimension	10 (263)	81 (2057)	154 (3907)	206 (5219)	284 (7218)	427 (10842)	505 (12820)	562 (14265)	
			Isolator Y-Dimension	87 (2206)								
			Point Load ¹	667 (303)	2092 (949)	3216 (1459)	3216 (1459)	2343 (1063)	1202 (545)	386 (175)	759 (344)	
050	0	J	Isolator X-Dimension	10 (263)	81 (2057)	154 (2908)	205 (5219)	284 (7218)	427 (10843)			
			Isolator Y-Dimension	87 (2206)								
			Point Load ¹	769 (349)	2600 (1179)	3083 (1398)	3083 (1398)	3113 (1412)	1014 (460)			
052	3	J	Isolator X-Dimension	10 (263)	81 (2057)	154 (3907)	206 (5219)	284 (7218)	427 (10842)	505 (12820)	562 (14265)	
			Isolator Y-Dimension	87 (2206)								
			Point Load ¹	772 (350)	2550 (1157)	3098 (1405)	3098 (1405)	3026 (1373)	1202 (545)	386 (175)	759 (344)	

5

NOTES:

1. Microchannel condenser coils only
2. Operating weight shown is for base unit (460/3/60, no options); selected options may add weight to unit. Contact your nearest Johnson Controls Sales Office for weight data.
3. All isolator mounting holes are 19mm.
4. Dimensions are in inches (mm) and weights are in pounds (kg)

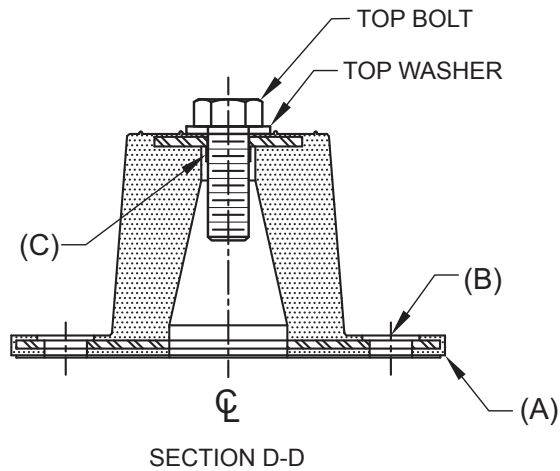
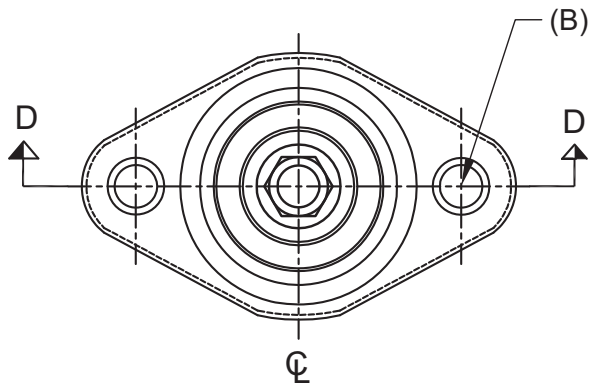
ELASTOMETRIC ISOLATOR INSTALLATION

LD13762C

1. Read the following instructions before beginning installation.
2. Isolators are shipped fully assembled and are to be positioned in accordance with the submittal drawings or as otherwise recommended.
3. Set isolators on floor, housekeeping pad or sub-base, ensuring that all isolator lines match the equipment mounting holes. The VMC group recommends that the isolator base (A) be installed on a level surface. Shim or grout as required, leveling all isolator bases to the same elevation (0.03125-inch maximum difference can be tolerated).
4. Bolt or anchor all isolators to supporting structure utilising base thru holes (B).
5. Remove top bolt and top washer. Place equipment on top of isolators so that mounting holes in equipment or base line up with threaded hole (C).
6. Reinstall top bolt and washer and tighten down.

ELASTOMETRIC ISOLATOR SPECIFICATIONS

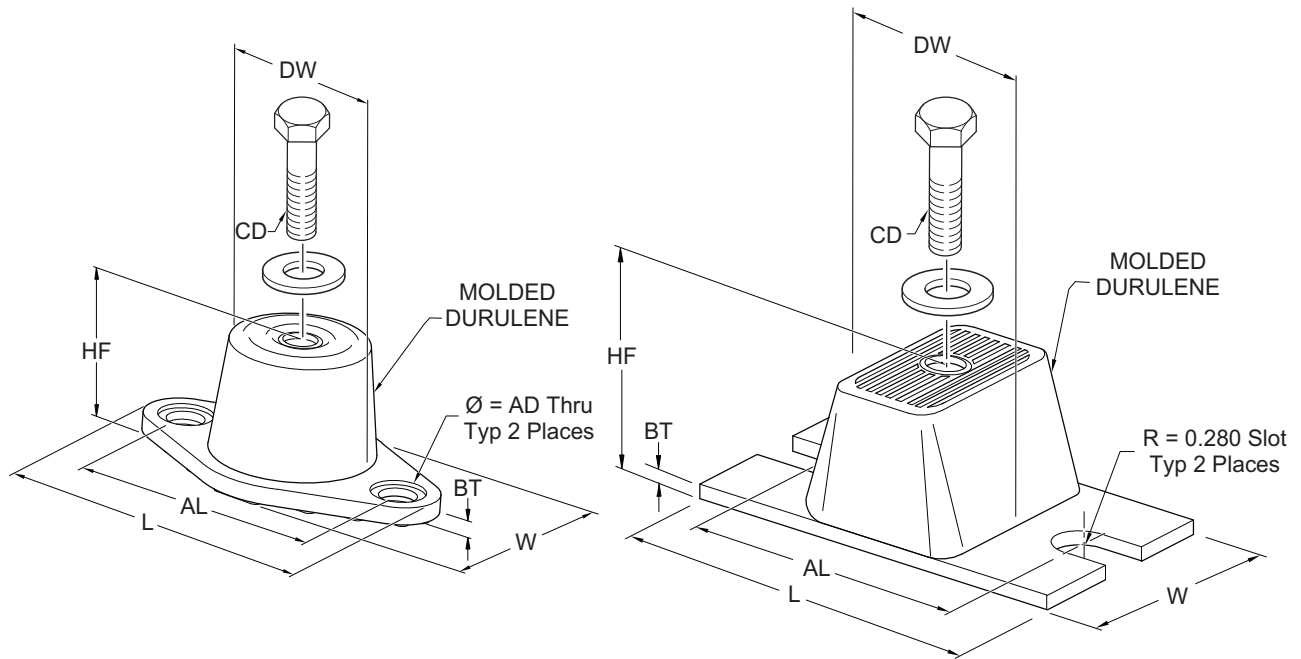

LD17304

MOUNT TYPE	DIMENSION DATA (INCHES)							
	L	W	HF	AL	AD	BT	CD	DW
RD1-WR	3.13	1.75	1.25	2.38	0.34	0.19	5/16-18 UNC X 3/4	1.25
RD2-WR	3.88	2.38	1.75	3.00	0.34	0.22	3/8-16 UNC X 1	1.75
RD3-WR	5.50	3.38	2.88	4.13	0.56	0.25	1/2-13 UNC X 1	2.50
RD4-WR	6.25	4.63	2.75	5.00	0.56	0.38	1/2-13 UNC X 1	3.00

MODEL NUMBER	ISOLATOR COLOR	WEIGHT RANGE (LBS)	WEIGHT RANGE (KGS)
RD-3-CHARCOAL-WR	CHARCOAL	Up thru 825	UP TO 374
RD-4-BRICK RED-WR	BRICK RED	826 thru 1688	375 - 766
RD-4-CHARCOAL-WR	CHARCOAL	1689 thru 4000	767 - 1814

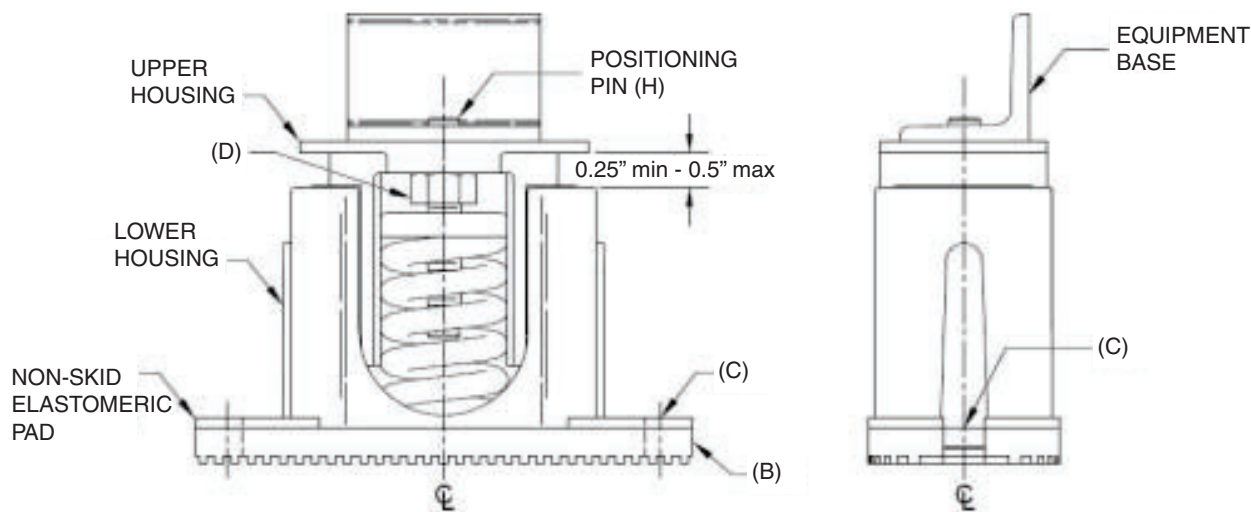
ONE INCH DEFLECTION ISOLATOR INSTALLATION

1. Read the following instructions before beginning installation.
2. Isolators are shipped fully assembled and are to be positioned in accordance with the submittal drawings or as otherwise recommended.
3. Set isolators on floor, housekeeping pad or sub-base, ensuring that all isolator centerlines match the equipment mounting holes. The VMC group recommends that the isolator base ("B") be installed on a level surface. Shim or grout as required, leveling all isolator bases to the same elevation (0.25-inch maximum difference can be tolerated).
4. Bolt or anchor all isolators to supporting structure utilizing base slotted holes ("C").
5. Place equipment on top of isolators making sure that mounting holes of the equipment line up with isolator positioning pin ("H").
6. Equipment or machine is at its full operating weight.
7. Adjust each isolator in sequence by turning spring adjusting bolt ("D") one full counterclockwise turn at a time. Repeat this procedure on all isolators, one at a time.
8. Continue adjusting each isolator until a minimum of 0.25" clearance is achieved between the lower housing and upper housing. (See illustration above).
9. Fine adjust isolators to level equipment.

ONE INCH DEFLECTION SPRING ISOLATOR SPECIFICATIONS

CPX-X-

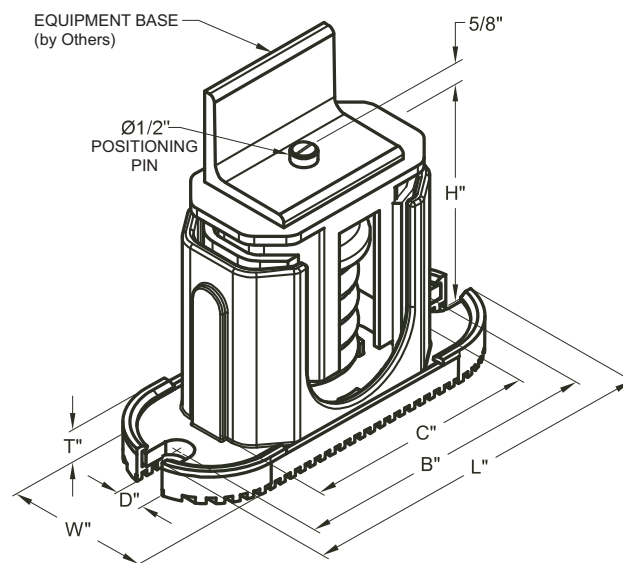

MOUNT TYPE	DIMENSION DATA (INCHES)						
	W	D	L	B	C	T	H
CP	3	5/8	7-3/4	6-1/2	4-3/4	1/2	5-5/8
C2P	3	5/8	10-1/2	9-1/4	7-3/4	9/16	6

MODEL NUMBER	COLOR CODE	RATED CAPACITY (FOR UNITS WITH ALL LOAD POINTS LESS THAN 1785 LBS (810 KG))		
		(LBS.)	(KG)	PART NUMBER
CP-1D-510	BLACK	Up thru 434	Up thru 197	029-25334-002
CP-1D-900	DARK GREEN	435 thru 765	198 thru 347	029-25334-003
CP-1D-1200	GRAY	766 thru 1020	348 thru 463	029-25334-004
CP-1D-1360	WHITE	1021 thru 1156	464 thru 524	029-25334-005
CP-1D-1785N	GRAY/RED	1157 thru 1785	525 thru 810	029-25334-006

MODEL NUMBER	COLOR CODE	RATED CAPACITY (FOR UNITS WITH ANY LOAD POINT ABOVE 1518 LBS (689 KG))		
		(LBS.)	(KG)	PART NUMBER
C2P-1D-1350	DARK PURPLE	Up thru 1148	Up to 521	029-25334-008
C2P-1D-1800	DARK GREEN	1149 thru 1530	522 - 694	029-25334-009
C2P-1D-2400	GRAY	1531 thru 2040	695 - 925	029-25334-010
C2P-1D-2720	WHITE	2041 thru 2312	926 - 1049	029-25334-012
C2P-1D-3570N	GRAY/RED	2313 thru 3570	1050 - 1619	029-25334-013

NOTES:

1. Use either all CP's or all CP2's at all locations on a unit.
2. Installation requires bolting or anchoring mount to support structure with a 2 x 0.625" diameter bolts or 2 x 0.5" diameter concrete anchors.
3. All springs are designed for 50% over-travel.

TWO INCH DEFLECTION ISOLATOR INSTALLATION AND ADJUSTMENT

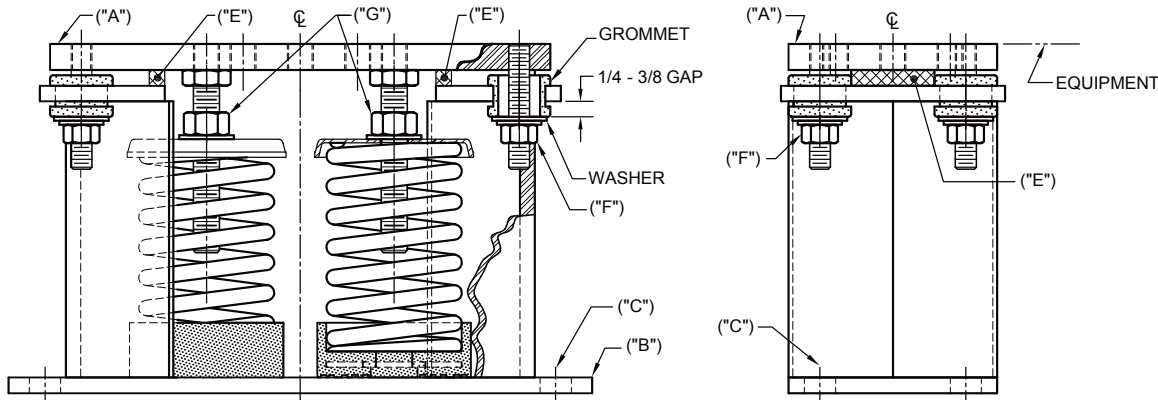

1. Read the following instructions before beginning installation.
2. Isolators are shipped fully assembled and are to be positioned in accordance with the submittal drawings or as otherwise recommended.
3. Set isolators on floor, housekeeping pad, or sub-base, ensuring that all isolator centerlines match the equipment mounting holes. The VMC group recommends that the isolator base plates ("B") be installed on a level surface. Shim or grout as required, leveling all isolator base plates to the same elevation (0.25-inch maximum difference can be tolerated).
4. Bolt or anchor all isolators to supporting structure utilizing base plate thru holes ("C") or weld base plate to supporting structure with 0.375" fillet weld 2" long @ 4" on center around entire base plate or as engineered for specific load and or field conditions.
5. Isolators are shipped to the job site with (2) removable spacer shims ("E") between the top plate and the housing. These shims must be in place when the equipment is positioned over the isolators.
6. With all shims ("E") in place, position equipment on top of plate ("A") of isolator. Bolt equipment securely to top plate of isolator using a minimum of 2 x 0.625" UNC A325 GRADE 5 SAE bolts or weld equipment or bracket to the top plate ("A") of isolator with a minimum 0.375" fillet welds 2" long @ 3" O.C. for a minimum total weld of 10". (All sides of equipment or bracket resting on top plate ("A") must be welded).
7. The adjustment process can only begin after the equipment or machine is at its full operating weight.
8. Back off each of the 4 limit stop lock nuts ("F") on the isolators 0.5".
9. Adjust each isolator in sequence by turning spring adjusting nuts ("G") one full clockwise turn at a time. Repeat this procedure on all isolators, one at a time. Check the limit stop lock nuts ("F") periodically to ensure that clearance between the washer and rubber grommet is maintained. Stop adjustment of isolator only when the top plate ("A") has risen just above the shim ("E").
10. Remove all spacer shims ("E").
11. Fine adjust isolators to level equipment.
12. Adjust all limit stop lock nuts ("F") per isolator, maintaining 0.25-to 0.375-inch gap. The limit stop nuts must be kept at this gap to ensure uniform bolt loading during uplift (as the case when equipment is drained).

TWO INCH DEFLECTION, RESTRAINED SPRING ISOLATOR SPECIFICATIONS

Y2RS

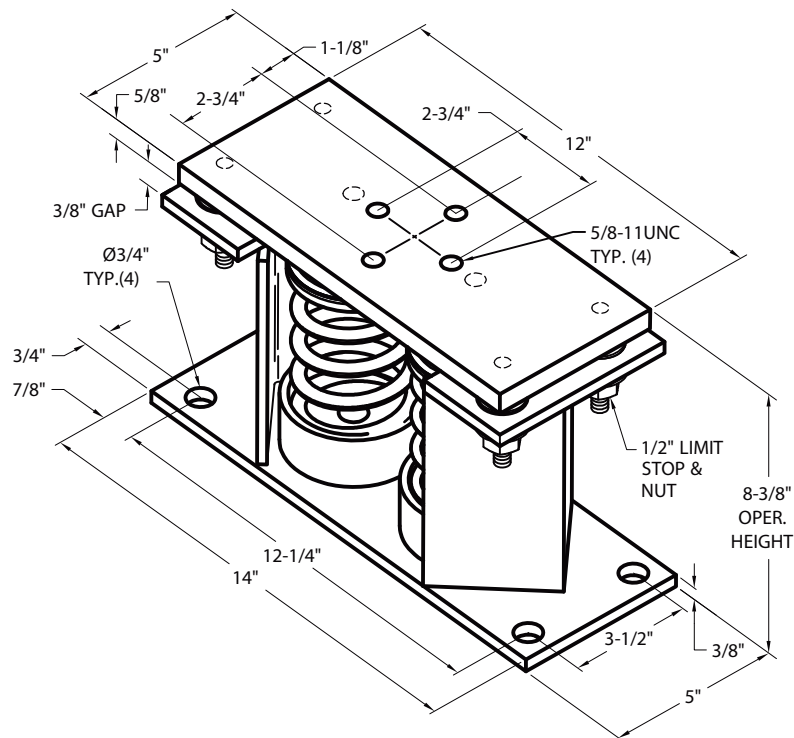

MODEL NUMBER	WEIGHT RANGE (LBS)	WEIGHT RANGE (KGS)	YORK P/N
Y2RSI-2D-460	Up thru 391	UP TO 177	029-25336-006
Y2RSI-2D-710	392 thru 604	178 - 274	029-25336-008
Y2RSI-2D-870	605 thru 740	275 - 336	029-25336-009
Y2RSI-2D-1200N	741 thru 1020	337 - 463	029-25336-010
Y2RSI-2D-1690	1021 thru 1437	464 - 652	029-25336-011
Y2RSI-2D-2640N	1438 thru 2244	653 - 1018	029-25336-012
Y2RSI-2D-2870N	2245 thru 2618	1019 - 1188	029-25336-013
Y2RSI-2D-3280N	2619 thru 3740	1189 - 1696	029-25336-014

NOTES:

1. All dimensions are in inches, interpret as per ANSI Y14
2. Equipment must be bolted or welded to the top plate to meet allowable seismic ratings.
3. All springs are designed for 50% overload capacity with exception of the 029-25336-013 and 029-25336-014.
4. Consult JCI for concrete installation.

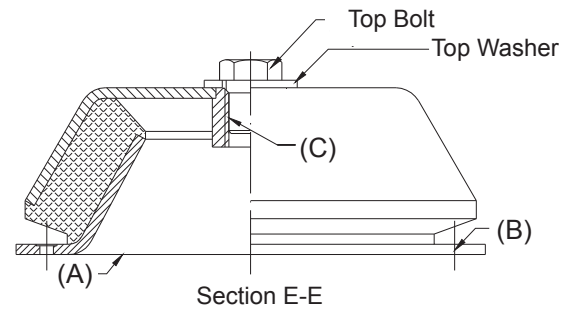
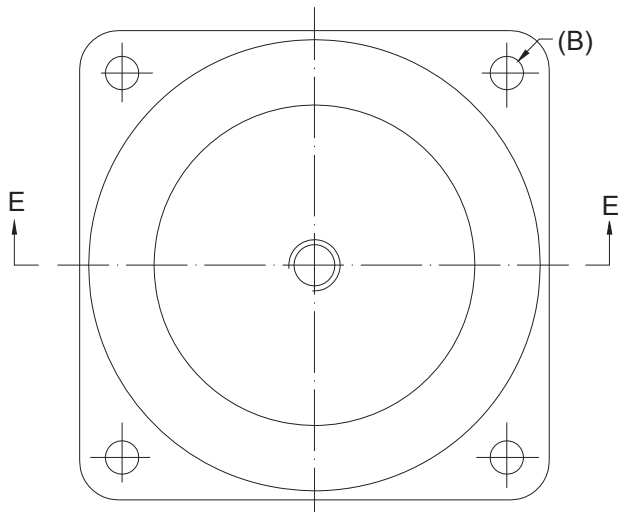
ELASTOMETRIC ISOLATOR INSTALLATION (GB CERTIFIED UNITS)

LD16179

1. Read the following instructions before beginning installation.
2. Isolators are shipped fully assembled and are to be positioned in accordance with the submittal drawings or as otherwise recommended.
3. Set isolators on the floor, housekeeping pad or subbase, ensuring that all isolator centerlines match the equipment mounting holes. It is recommended that the isolator base (A) be installed on a level surface. Shim or grout the isolator as required, leveling all isolator bases to the same elevation. The maximum difference that can be tolerated is 0.03125" (0.78 mm).
4. Bolt or anchor all isolators to the supporting structure utilizing base thru holes (B).
5. Remove the top bolt and top washer. Place equipment on top of the isolators so that the mounting holes in the equipment or base line up with the threaded hole (C).
6. Reinstall the top bolt and washer and tighten the bolt down.

ELASTOMETRIC ISOLATOR SPECIFICATIONS (GB CERTIFIED UNITS) SPECIFICATIONS

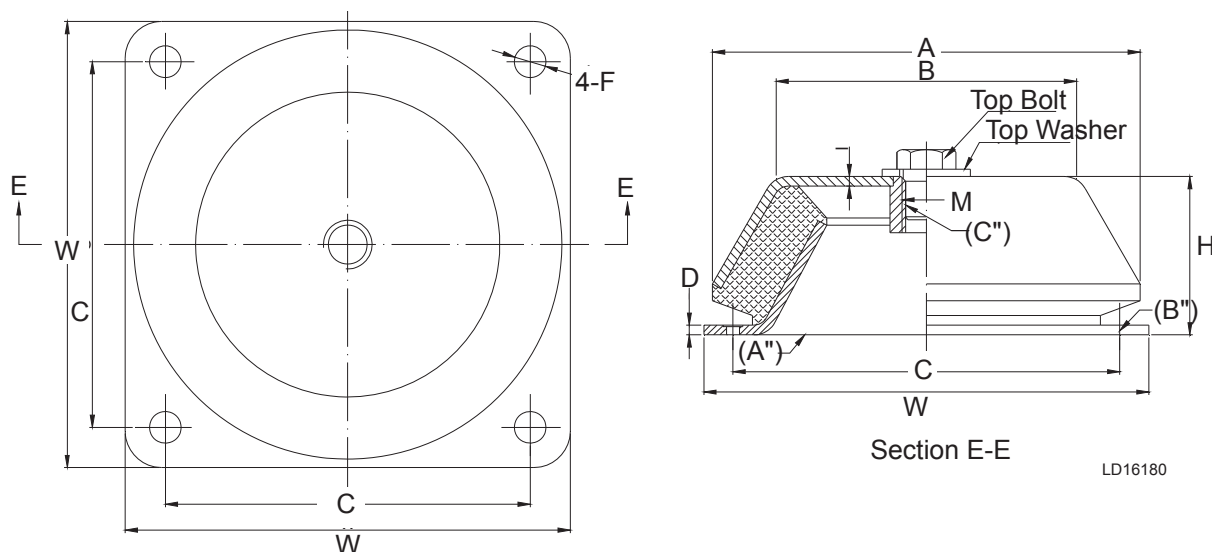

MOUNT TYPE	DIMENSION DATA (MM)							
	A	B	C	W	H	D	M	F
JG 1	Φ 146	Φ 95	125	150	55	3	M16	Φ 13
JG 2	Φ 176	Φ 125	150	183	65	4	M20	Φ 13

MODEL NUMBER	RATED CAPACITY FOR UNITS WITH ALL LOAD POINTS LESS THAN 1984 LBS (900 KG)		
	WEIGHT RANGE		PART NUMBER
	(LBS.)	RANGE (KG)	
JG 1-1	331 thru 661	150 thru 300	028G00031A035
JG 1-2	662 thru 1213	301 thru 550	028G00031A036
JG 1-3	1214 thru 1984	551 thru 900	028G00031A037

MODEL NUMBER	RATED CAPACITY FOR UNITS WITH ALL LOAD POINTS LESS THAN 4409 LBS (2000 KG)		
	WEIGHT RANGE		PART NUMBER
	(LBS.)	RANGE (KG)	
JG 1-1	882 thru 1984	400 thru 900	028G00031A038
JG 1-2	1985 thru 3527	901 thru 1600	028G00031A039
JG 1-3	3528 thru 4409	1601 thru 2000	028G00031A040

NOTES:

- All dimensions are in millimeters.
- Use either all JG 1's or all JG 2's at all locations on a unit.
- Installation requires bolting or anchoring mount to support structure with 4 x 0.5122" (4 x 13.0 mm) diameter bolts or 2 x 0.5" (2 x 12.7mm) diameter concrete anchors.

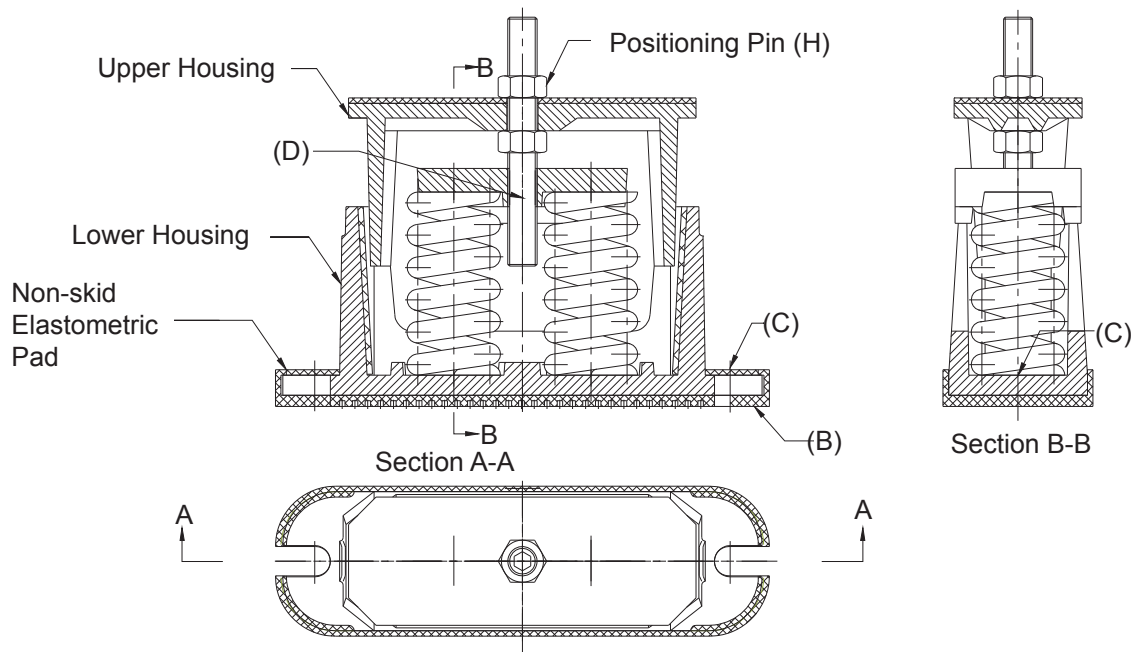
ONE INCH DEFLECTION ISOLATOR INSTALLATION (GB CERTIFIED UNITS)

LD16181

1. Read the following instructions before beginning installation.
2. Isolators are shipped fully assembled and are to be positioned in accordance with the submittal drawings or as otherwise recommended.
3. Set isolators on the floor, housekeeping pad or subbase, ensuring that all the isolator centerlines match the equipment mounting holes. It is recommended that the isolator base (B) be installed on a level surface. Shim or grout the isolators as required, leveling all isolator bases to the same elevation. The maximum difference that can be tolerated is 0.25" (6.3 mm).
4. Bolt or anchor all isolators to the supporting structure utilizing base slotted holes (C).
5. Place the equipment on top of the isolators making sure that the mounting holes on the equipment line up with the isolator positioning pin (H).
6. Ensure the equipment is at full operating weight before adjusting the isolators.
7. Adjust each isolator in sequence by turning the spring adjusting bolt (D) one full counterclockwise turn at a time. Repeat this procedure on all isolators, one at a time.
8. Continue adjusting each isolator until the same clearance is achieved between the lower housing and the upper housing for all isolators.
9. Fine adjust isolators to level the equipment.

ONE INCH DEFLECTION ISOLATOR INSTALLATION (GB CERTIFIED UNITS) SPECIFICATIONS

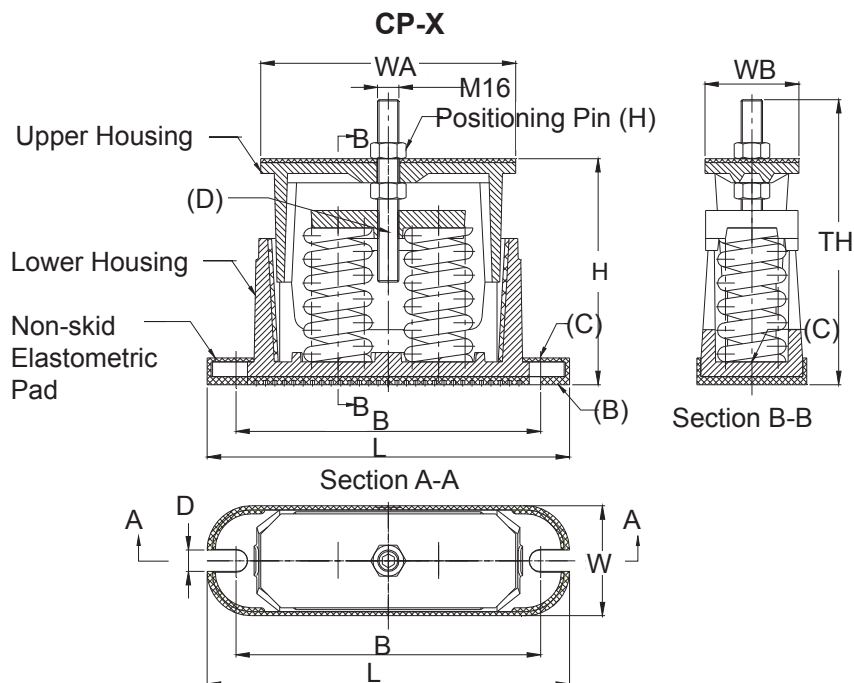

LD16182

MOUNT TYPE	DIMENSION DATA (MM)							
	WA	WB	H	TH	B	L	D	W
CP-2	190	70	168	211	228	270	16	80
CP-4	193	130	160	202	228	270	16	142

MODEL NUMBER	SPRING NUMBER	RATED CAPACITY FOR UNITS WITH ALL LOAD POINTS LESS THAN 1808 LBS (820 KG)		
		WEIGHT RANGE		PART NUMBER
		(LBS.)	RANGE (KG)	
CP-2-200	2	Up thru 441	Up thru 200	028G00031A028
CP-2-300	2	442 thru 661	201 thru 300	028G00031A029
CP-2-400	2	662 thru 882	301 thru 400	029G23000A018
CP-2-550	2	883 thru 1213	401 thru 550	029G23000A019
CP-2-680	2	1214 thru 1499	551 thru 680	028G00031A030
CP-2-820	2	1500 thru 1808	681 thru 820	029G23000A020

MODEL NUMBER	SPRING NUMBER	RATED CAPACITY FOR UNITS WITH ALL LOAD POINTS LESS THAN 3594 LBS (1630 KG)		
		WEIGHT RANGE		PART NUMBER
		(LBS.)	RANGE (KG)	
CP-4-400	4	Up thru 882	Up thru 400	029G23000A021
CP-4-550	4	883 thru 1213	401 thru 550	029G23000A022
CP-4-680	4	1214 thru 1499	551 thru 680	029G23000A023
CP-4-820	4	1500 thru 1808	681 thru 820	029G23000A024
CP-4-1100	4	1809 thru 2425	821 thru 1100	029G23000A025
CP-4-1360	4	2426 thru 2998	1101 thru 1360	029G23000A026
CP-4-1630	4	2999 thru 3594	1361 thru 1630	029G23000A027

NOTES:

1. All dimensions are in millimeters.
2. Use either all CP-2's or all CP-4's at all locations on a unit.
3. Installation requires bolting or anchoring mount to support structure with 2 x 0.625" (2x16 mm) diameter bolts or 2 x 0.5" (2x12.7mm) diameter concrete anchors.

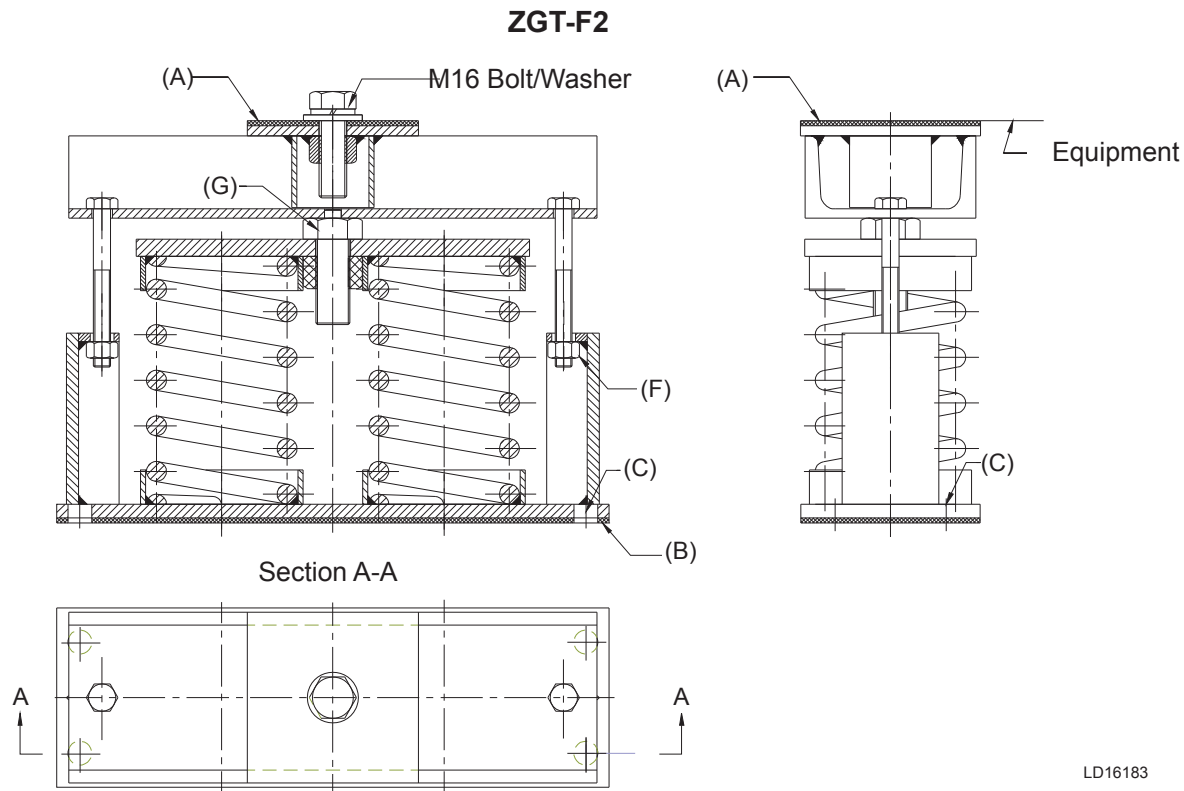
TWO INCH DEFLECTION ISOLATOR INSTALLATION AND ADJUSTMENT (GB CERTIFIED UNITS)

1. Read the following instructions before beginning installation.
2. Isolators are shipped fully assembled and are to be positioned in accordance with the submittal drawings or as otherwise recommended.
3. Set isolators on the floor, housekeeping pad, or subbase, ensuring that all isolator centerlines match the equipment mounting holes. It is recommended that the isolator base plates (B) be installed on a level surface. Shim or grout the isolators as required, leveling all isolator bases to the same elevation. The maximum difference that can be tolerated is 0.25" (6.35 mm).
4. Bolt or anchor all isolators to the supporting structure utilizing base plate thru holes (C) or weld the base plate to the supporting structure with 0.375" (9.5mm) fillet weld 2" (50.8mm) long @ 4" (101.6mm) on center around the entire base plate; or as engineered for specific load and or field conditions.
5. Ensure the equipment is at full operating weight before adjusting the isolators.
6. Bolt or anchor all isolators to the supporting structure utilizing the base slotted holes (C).
7. Place equipment on top of the isolators making sure that mounting holes of the equipment line up with the isolator M16 bolt.
8. Adjust each isolator in sequence by turning spring adjusting nuts (G) one full clockwise turn at a time. Repeat this procedure on all isolators, one at a time. Continue adjusting each isolator until the same clearance is achieved between the lower housing and top plate. Check the limit stop lock nuts (F) periodically to ensure that clearance between the washer and grommet is maintained.
9. Fine adjust the isolators to level equipment.
10. Adjust all limit stop lock nuts (F) per isolator, maintaining a gap between 0.25" (6.3mm) to 0.375" (9.5mm). The limit stop lock nuts must be kept at this gap to ensure uniform bolt loading during uplift (as is the case when equipment is drained)

TWO INCH DEFLECTION, RESTRAINED SPRING ISOLATOR SPECIFICATIONS (GB CERTIFIED UNITS)

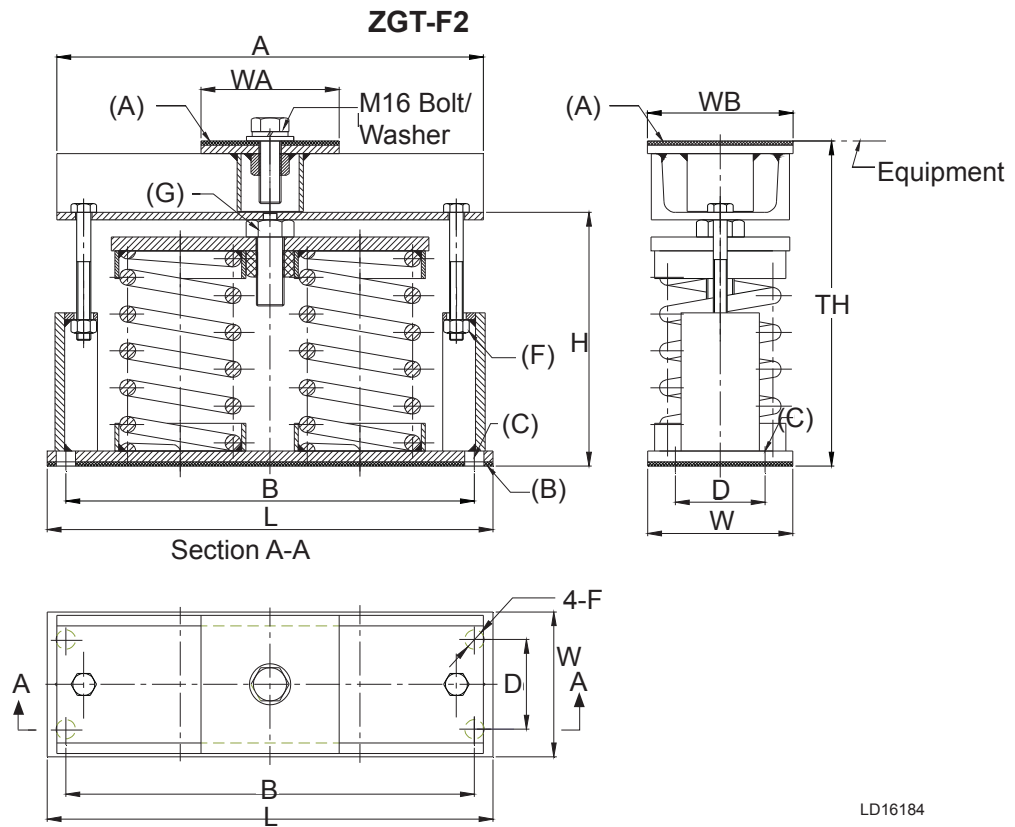

LD16184

MOUNT TYPE	DIMENSION DATA (MM)									
	A	WA	WB	W	H	TH	B	L	D	F
ZGT-F2	290	110	110	110	150	200	283	310	60	Φ16

MODEL NUMBER	RATED CAPACITY FOR UNITS WITH ALL LOAD POINTS LESS THAN 3527 LBS (1600 KG)		
	WEIGHT RANGE		PART NUMBER
	(LBS.)	RANGE (KG)	
ZGT-F2-200	0 thru 441	0 thru 200	029G23000A031
ZGT-F2-300	442 thru 661	201 thru 300	029G23000A032
ZGT-F2-350	662 thru 772	301 thru 350	029G23000A033
ZGT-F2-500	773 thru 1102	351 thru 500	029G23000A034
ZGT-F2-650	1103 thru 1433	501 thru 650	029G23000A035
ZGT-F2-1000	1434 thru 2205	651 thru 1000	029G23000A036
ZGT-F2-1200	2206 thru 2646	1001 thru 1200	029G23000A037
ZGT-F2-1600	2647 thru 3527	1201 thru 1600	029G23000A038

NOTES:

1. All dimensions are in millimeters.
2. Equipment must be bolted or welded to the top plate to meet allowable seismic ratings.
3. Consult Johnson Controls for concrete installation.

THIS PAGE INTENTIONALLY LEFT BLANK

SECTION 6 - COMMISSIONING

PREPARATION



Commissioning of this unit should only be carried out by Johnson Controls Authorized personnel.

Commissioning personnel should be thoroughly familiar with the information contained in this document before starting the unit.

The following basic checks should be made with the customer power to the unit switched OFF.



Proper electrical lock out and tag out procedures must be followed.

Inspection

Inspect unit for installation damage. If found, take action and/or repair as appropriate.

Refrigerant Charge

Packaged units are normally shipped as standard with a full refrigerant operating charge. Check that refrigerant pressure is present in both systems and that no leaks are apparent. If no pressure is present, a leak test must be undertaken, the leak(s) located and repaired.

Do not evacuate or liquid charge with static water in the evaporator. Turn the pump on. Take care to liquid charge slowly to avoid excessive thermal stress at the charging point and to assure the refrigerant temperature in the evaporator does not go below the freezing point with liquid refrigerant in the evaporator. Once the vacuum is broken, charge into the evaporator or flash tank with the Condenser Drain Valve (Flash Tank Feed) open and the chilled liquid pump ON to the full operating charge, as detailed in *SECTION 5 - TECHNICAL DATA*.

Correct System Refrigerant Charge

The charge on a system should always be checked when operating for several minutes at full speed with the system stable. Stable conditions are defined as operation without fan cycling, economizer cycling, VI solenoid cycling, or any other system transient conditions. Ideal refrigerant charge will be reached when the refrigerant level in the evaporator is near the middle of the evaporator sight glass.

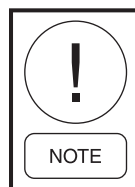

Refrigerant should not be added or removed unless the level is at the bottom or the top of the glass. It is not necessary to weigh charge unless the entire charge has been lost. The ease of charging is possible since the microchannel coils hold only a small amount of refrigerant charge. A charging valve is located between the fixed orifice and the evaporator for adjusting charge. Charge should be added as liquid with the pump ON and liquid flowing through the evaporator.

Service and Oil Line Valves

Open each compressor oil, economizer, and discharge ball or service valves. If valves are of the back-seat type, open them fully (counterclockwise) then close one turn of the stem to ensure operating pressure is fed to pressure transducers.

Compressor Oil

To add oil to a circuit - connect a YORK hand oil pump (Part No. 470-10654-000) to the 1/4" (6.35 mm) oil charging valve on the oil separator piping with a length of clean hose or copper line, but do not tighten the flare nut. Using clean oil of the correct type ("L" oil), pump oil until all air has been purged from the hose then tighten the nut. Stroke the oil pump to add oil to the oil system. While the compressor is running at full speed, the oil level should be visible in the sight glass of the oil separator. Approximately 2 to 3.1 gallons (7.5 to 11.6 liters) are present in each refrigerant system.

Avoid levels in either oil separator that are above the middle of the top sight glass. This may cause excessive oil carryover in the system. High oil concentration in the system may cause nuisance trips resulting from incorrect readings on the level sensor and temperature sensors. Temperature sensor errors may result in poor liquid control which will result in liquid overfeed and subsequently damage the compressor. High oil carryover may also cause liquid to be returned to the compressor, which can damage the compressor.

Fans

Check that all fans are free to rotate and are not damaged. Ensure blades are at the same height when rotated. Ensure fan guards are securely fixed.

Isolation / Protection

Verify all sources of electrical supply to the unit are taken from a single point of isolation. Check that the maximum recommended fuse sizes given in *SECTION 5 - TECHNICAL DATA* has not been exceeded.

Control Panel

Check the panel to see that it is free of foreign materials (wire, metal chips, etc.) and clean out if required.

Power Connections

Check that the customer power cables are connected correctly to the terminal blocks or optional circuit breaker. Ensure that connections of power cables within the panels to the circuit breaker or terminal blocks are tight.

Grounding

Verify that the unit's protective ground terminal(s) are properly connected to a suitable grounding point. Ensure that all unit internal ground connections are tight.

Water System

Verify the chilled liquid system has been installed correctly, and has been commissioned with the correct direction of water flow through the evaporator. The inlet should be at the bottom connection on a two pass evaporator. Purge air from the top of the evaporator using the plugged air vent mounted on the top of the evaporator body.

Flow rates and pressure drops must be within the limits given in *SECTION 5 - TECHNICAL DATA*. Operation outside of these limits is undesirable and could cause damage.

If main power must be switched OFF for maintenance or shutdown, precautions must be taken. See *Unit Maintenance and Shutdown in Sub-freezing Conditions on Page 96*. Before placing the unit back in service, valves should be opened and power must be switched on (if power is removed for more than 8 hours) for at least 8 hours (24 hours if ambient temperature is below 86°F [30°C]) before the unit is restarted.

Flow Switch

Verify a chilled water flow switch is correctly fitted in the customer's piping on the evaporator outlet, and wired into the control panel correctly using shielded cable.

There should be a straight run of at least five pipe diameters on either side of the flow switch. The flow switch should be connected to Terminals 2 and 13 in the panel.

Temperature Sensor(s)

Ensure the leaving liquid temperature sensor is coated with heat conductive compound (Part No. 013-00890-000) and is inserted to the bottom of the water outlet sensor well in the evaporator. This sensor is part of the pump control freeze protection operation. It provides some freeze protection and must always be fully inserted in the water outlet sensor well.

Programmed Options

Verify that the options factory-programmed into the Micro Panel are in accordance with the customer's order requirements by pressing the OPTIONS key on the keypad and reading the settings from the display.

Programmed Settings

Ensure the system cutout and operational settings are in accordance with the operating requirements by pressing the PROGRAM key.

Date and Time

Program the date and time by first ensuring that the CLK jumper JP2 on the Chiller Control Board is in the ON position. Then press the DATE/TIME key and set the date and time (see *SECTION 8 - MICROPANEL Date/Time and Schedule Keys on Page 132*).

Start/Stop Schedule

Program the daily and holiday start/stop by pressing the SCHEDULE key (see SECTION 8 - MICROPANEL Date/Time and Schedule Keys on Page 132).

Setpoint and Remote Offset

Set the required leaving chilled liquid temperature setpoint and Control Range under the SETPOINTS key. The chilled liquid temperature control settings need to be set according to the required operating conditions.

If remote temperature reset (offset) is to be used, the maximum reset required must be programmed by pressing the SETPOINTS key (see SECTION 8 - MICROPANEL Setpoints Key on Page 124).

FIRST TIME START UP



During the commissioning period there should be sufficient heat load to run the unit under stable full load operation to enable the unit controls, and system operation to be set up correctly, and a commissioning log taken.

Interlocks

Verify that liquid is flowing through the evaporator and that heat load is present. Ensure that any remote run interlocks are in the run position and that the Daily Schedule requires the unit to run or is overridden.

Unit Switch

Place the UNIT switch on the keypad to the ON position.

Startup

Press the SYSTEM SWITCHES key and place the system switch for System 1 to the ON position. There may be a few seconds delay before the first compressor starts because of the anti-recycle timer). Be ready when each compressor starts, to switch the UNIT switch OFF immediately, if any unusual noises or other adverse conditions develop.

When a compressor is running, the controller monitors oil pressure, motor current, and various other system parameters such as discharge pressure, chilled liquid temperature, etc. Should any problems occur; the control system will immediately take appropriate action and display the nature of the fault.

Oil Pressure

When a compressor starts, press the relevant “System Pressures” key and verify that oil differential pressure (oil pressure-suction pressure) develops immediately. If oil pressure does not develop, the automatic controls will shut down the compressor. Under no circumstances should a restart attempt be made on a compressor, which does not develop oil pressure immediately. Switch the UNIT switch to the OFF position.

Loading

Once the unit has been started, all operations are fully automatic. After an initial period at minimum capacity, the control system will adjust the unit load depending on the chilled liquid temperature and rate of temperature change. If a high heat load is present, the controller will increase the speed of the compressor(s).

Condenser and Fan Rotation

Once a compressor is running, discharge pressure rises as refrigerant is pumped into the air-cooled condenser coils. This pressure is controlled by stages of fans to ensure maximum unit efficiency while maintaining sufficient pressure for correct operation of the condensers and the lubrication system.

As discharge pressure rises, the condenser fans operate in stages or ramp up in speed to control the pressure. Verify that the fans operate in the correct direction of rotation and operation is correct for the type of unit.

System Charge

Check system charge at steady full compressor load only. It is important that all fans are running for the system. The refrigerant level in the evaporator should be about in the middle of the sight glass. Unless levels are at the bottom or the top of the sight glass, they should not cause concern or require adding or removing charge.

GENERAL OPERATION

After completion of the above checks for System 1, switch OFF the SYS 1 switch on the keypad and repeat the process for each subsequent system. When all run correctly, stop the unit, switch all applicable switches to the ‘ON’ position and restart the unit.

Assure all checks are completed in the Equipment Pre - Startup and Startup Checklist. The chiller is then ready to be placed into operation.

Operation in Sub-freezing Conditions

The YVAA may be operated in sub-freezing conditions if the following freeze protections are taken :

- A. A suction service valve electric actuator is installed. Chiller software will operate the actuator in order to protect against freezing due to evaporator refrigerant migration.

-or-

- B. No suction service valve is installed but the water circuit valves are kept open, there is continuous power to the chiller and pump for chilled water pump control, and the pump will operate and circulate water through the evaporator whenever commanded by the chiller.



The above operation is only advised if uninterrupted power can be ensured. Unforeseen power interruptions can damage the evaporator in a very short time frame if the temperature falls below freezing.

If there is potential for power loss, Johnson Controls recommends the water in the chilled water circuit be replaced with an appropriate water-to-glycol concentration.

Unit Maintenance and Shutdown in Sub-freezing Conditions

If the YVAA is maintained or shut down and will be subjected to sub-freezing conditions, it is critical to protect against evaporator and waterbox freeze damage. Johnson Controls recommends the following options (in order of freeze protection level) be performed on each circuit.

- A. **Glycol:** Replace water with an appropriate water to glycol concentration of antifreeze.

-or-

- B. **Drain:** Remove power to the waterbox heaters. Close the water valves, drain the evaporator, and leave the evaporator drain valves open.

-or-

- C. **Refrigerant Valve - Off:** Close the water valves, close flash tank drain valves, close the suction service valves and leave power to the chiller for evaporator heater mat and waterbox heater operation. For units without a suction service valve, close the discharge and compressor oil valves.

-or-

- D. **Pump Control:** Keep power to the chiller in order to have control over chilled water pumps and heater operation and leave the water circuit valves open. This will enable water to circulate through the evaporator to avoid freezing.



Options A and B are the recommended processes for unit maintenance and shutdown. Unforeseen power interruptions can damage the evaporator in a very short time frame if the temperature falls below freezing.



Failure to follow Johnson Controls freeze protection recommendations can void the warranty.

SECTION 7 - OPERATION

OPERATING CONTROLS

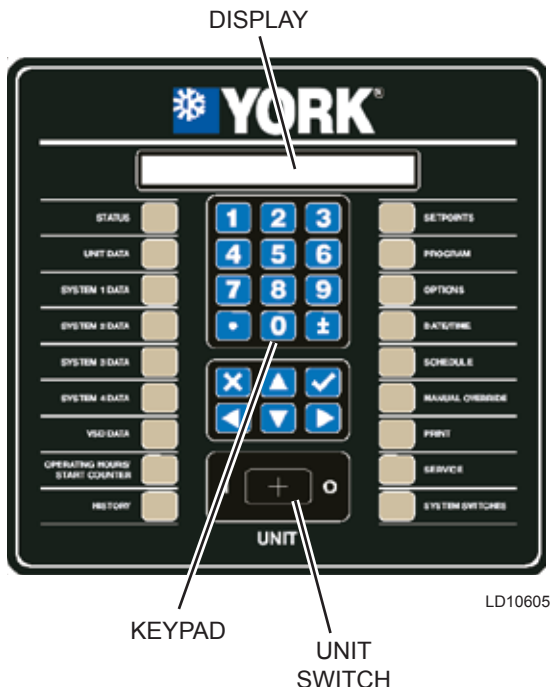

FIGURE 16 - KEYBOARD AND DISPLAY

Unit Switch

A double pole single throw ON/OFF rocker switch on the front of the control panel is used to turn the entire chiller ON and OFF. When the switch is placed in the OFF position, the entire unit shuts down immediately and all systems will be disabled. One pole of the UNIT switch contacts is wired to the Run Signal input and the Chiller Control Board “UNIT switch X” digital input (X equals System 1 or 2). Separate System Fuses are also wired in series with each set of UNIT switch contacts. If either fuse is pulled or blown, only the system with the good fuse (Input is high) will run. When both inputs are high, the entire chiller will be enabled to run. When both inputs are low, the chiller will be disabled as a UNIT switch OFF Shutdown.

Keypad

An operator keypad allows complete control of the system from a central location. The keypad offers a multitude of command keys on the left and right side of the keypad to access displays, program setpoints, history data, and initiate system commands. Most keys have multiple displays that can be accessed by repetitively pressing the key or by pressing the ▲, ▼, ◀, and ▶ (ARROW) keys. The keypad utilizes an overlay to convert the keypad to various languages.

The keypad also contains keys in the center section for data entry in the various program modes. These keys are listed below:

- 0-9 Keys NUMERIC KEYPAD
- PERIOD/DECIMAL
- +/- PLUS/MINUS
- ✓ ENTER
- ✕ CANCEL
- ▲ UP ARROW
- ▼ DOWN ARROW
- ◀ LEFT ARROW
- ▶ RIGHT ARROW

The numeric keys allow keying numeric values into memory.

The • (PERIOD/DECIMAL) key allows keying a decimal point into numeric values.

The +/- (PLUS/MINUS) key allows making numeric values negative.

The ✓ (ENTER) key stores program changes into memory.

The X (CANCEL) key is used to cancel the data entry operation and returns the programmed value to the original value, before any programming changes were made, when an error is made.

The ▲ (UP ARROW) and ▼ (DOWN ARROW) keys allow scrolling backward (▲) and forward (▼) through items to be programmed under keys such as the PROGRAM or OPTIONS key.

The ▲ (UP ARROW) and ▼ (DOWN ARROW) keys also allow scrolling forward (▼) or backwards (▲) through data display keys that have multiple displays under keys such as UNIT DATA, SYSTEM DATA, HISTORY, PROGRAM, OPTIONS, etc. The arrow keys can be used instead of repeatedly pressing the data key to see the multiple displays under a key. Once the ▲ ▼ (ARROW) keys are pressed and used for scrolling, pressing the original data key will return to the first display message displayed under the data (UNIT DATA, SYSTEM DATA, etc.) keys.

The ◀ ▶ (LEFT and RIGHT ARROW) keys allow scrolling between non-numeric program choices under the OPTION, DATE/TIME, and SCHEDULE keys.

The ◀ (LEFT ARROW) key allows programming the default value when programming numeric values. For changing numeric values, the ▶ (RIGHT ARROW) key has no function.

The ◀ ▶ (ARROW) keys also allow scrolling sideways between the same displays on different systems. For example, pressing the ▶ (RIGHT ARROW) key while viewing the system #1 suction pressure moves the display to system #2 suction pressure.

Pressing the ◀ (LEFT ARROW) key moves the opposite direction. The arrow keys also allow fast scrolling through data under keys such as HISTORY by enabling the operator to move between subgroups of data such as Unit, System, and VSD data.

Keypad Data Entry Mode

For numeric programmable items, the data entry mode is entered by pressing any of the number keys, the decimal point key, or the +/- key. When the data entry mode is entered, the data from the key press will be entered and the cursor will appear under the position where the data is being entered.

For non-numeric programmable items, data entry mode is entered by pressing the ◀ or ▶ (ARROW) keys. When the data entry mode is entered, the cursor will appear under the first position of the non-numeric string. The programmable choice may be changed by pressing the ◀ or ▶ (ARROW) keys.

To exit the data entry mode and store the programmed value, the ✓ (ENTER) key must be pressed. When the ✓ (ENTER) key is pressed, the cursor will disappear.

The data entry mode may also be exited by pressing the X (CANCEL) key. The programmed data will be returned to its original value when the X (CANCEL) key is pressed.

When the data entry mode is exited, the cursor will disappear. If any other key is pressed while in the Data Entry Mode, the following display will appear for 2 seconds indicating the user must choose between accepting or canceling the change:

XXXXXXXXXX PRESS ✓ TO ACCEPT VALUE OR
X TO CANCEL DATA ENTRY

If the ✓ (ENTER) key was pressed from the data entry mode and the numeric value entered was out of range, the following message will appear for 2 seconds followed by the original data display.

XXXXXXXXXXXX OUT OF RANGE TRY AGAIN!
XX

Display

The 80 character (2 lines of 40 characters per line) display is a Liquid Crystal Display (LCD) used for displaying unit parameters, system parameters, and operator messages. The display has an LED backlight background for night viewing and is viewable in direct sunlight.

Anti-recycle Timer

On power-up of the control panel, the anti-recycle timer for each system will be set to 120 seconds and must time out before a compressor is allowed to start.

Whenever a system starts, the anti-recycle timer for all systems will be set to 120 seconds and will count down from the time the motor starts. The timer must time out before another compressor is allowed to start.

Whenever a system shuts down, the anti-recycle timer for that system will be set to 120 seconds. The timer must time out before the system is allowed to restart.

Evaporator Pump Control

The evaporator pump dry contacts are energized when any of the following conditions are true:

- If a Low Leaving Chilled Liquid Fault occurs.
- Whenever a compressor is running.
- The Daily Schedule is ON and the UNIT switch is ON.

Even if one of above is true, the pump will not run if the panel has been powered up for less than 30 seconds or if the pump has run in the last 30 seconds to prevent pump motor overheating.

Evaporator Heater Control

The evaporator heater is controlled by ambient air temperature. If no systems are running and the ambient temperature drops below 4.4 °C (40°F), the heater is turned ON. If no systems are running and the temperature rises above 7.2°C (45°F) the heater is turned OFF. Whenever a system is running, the evapo-

rator heater is turned OFF. Both evaporator heater outputs will always be turned ON and OFF together. An under voltage condition will keep the heater OFF until full voltage is restored to the system.

Compressor Heater Control

Each compressor has its own heater. The purpose of the heater is to assure refrigerant does not condense in the compressor. There is no oil sump, but refrigerant could possibly condense in the rotors or the motor housing. The heater will be OFF whenever the respective compressor is running. As soon as the compressor shuts OFF, the heater will turn ON as long as all motor temperature sensors in the compressor read less than 70°C (158°F). The heater will turn OFF, if any internal compressor motor temperature sensor reads more than 71.1°C (160°F).

Alarms

Each system has its own alarm. The Alarm output is ON (dry contact closed) when no fault condition is present and OFF (dry contact open) to indicate an alarm situation. The Alarm will be activated (contacts open), if any of the following are true.

- A System is faulted or inhibited from starting for more than 5 seconds.
- The Unit is faulted or inhibited from starting for more than 5 seconds.
- A System is locked out.
- The Unit is locked out.
- Power is removed from the chiller.

Chiller Run Contact

The Chiller Run dry contact is closed whenever any system is running. It is open when all systems are shut OFF.

Flow Switch Control

A chilled liquid flow switch of suitable type MUST be connected between Terminals 2 and 13 of 1TB to provide protection against loss of liquid flow, which will cause evaporator freeze-up if the chiller is permitted to run.

Remote Run / Stop

A Remote Run/Stop input is available for each system.

BASIC OPERATING SEQUENCE

Start Sequence and Loading

To initiate the start sequence of the chiller, the following conditions must be satisfied before the precharge of the DC Bus will take place:

- UNIT SWITCH must be ON.
- At least one System Switch is ON
- Run permissive inputs (Remote Cycling Contacts) must be closed.
- No unit faults exist.
- No unit start inhibits exist.
- At least one system not faulted or inhibited.
- The Daily Schedule is calling for the chiller to run.
- The Flow Switch is closed.
- Leaving Chilled Liquid Setpoint is above the Setpoint plus CR (Setpoint High Limit).

Once the precharge takes place, if the anti-recycle timer is timed out the chiller control system on the Chiller Control Board will select the number of compressors to start and begin operation of the compressors. The compressor(s) speed will be ramped to the minimum start frequency and increase speed as needed in an effort to regulate the leaving chilled liquid temperature to meet the desired Setpoint. Unit Warnings

UNIT WARNING

Unit Warning Operation

Unit warnings are caused when a condition is present requiring operator intervention to restart the unit. All setpoints, program values, and options should be checked before operating the unit. Warnings are not logged to the history buffer. If a unit warning is in effect, the message will be displayed to the operator when the STATUS key is pressed.

Low Battery Warning

The LOW BATTERY WARNING can only occur at unit power-up. On micropanel power-up, the RTC battery is checked to see if it is still operational. If it is, normal unit operation is allowed. If the battery voltage is determined to be low, the following warning message is displayed indefinitely.

UNIT WARNING: !! LOW BATTERY !!
CHECK SETPOINTS/PROGRAM/OPTIONS/TIME

If a low battery condition exists, all programmed setpoints, program values, time, schedule, and history buffers will have been lost. These values will all be reset to their default values, which may not be the desired operating values. Once a bad battery is detected, the unit will be prevented from running until the MANUAL OVERRIDE key is pressed. Once the MANUAL OVERRIDE key is pressed, the anti recycle timers will be set to the programmed default anti recycle time to allow the operator sufficient time to check setpoints, program values, etc.

If a low battery is detected, it should be replaced as soon as possible. The programmed values will all be lost and the unit will be prevented from running on the next power interruption.

Invalid Number of Compressors Warning

The INVALID NUMBER OF COMPRESSORS SELECTED Warning will occur after the VSD has been initialized, if no "Number of Compressors Select" jumpers are installed or if more than 1 jumper is installed. The following warning message will be displayed indefinitely.

**UNIT WARNING:
INVALID NUMBER OF COMPRESSORS SELECTED**

To clear this warning, both the control panel and VSD control voltage must be turned OFF and the jumpers properly installed in the VSD wiring harness.

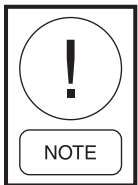

These jumpers are factory installed in the wire harness plug and should not require changes.

Invalid Serial Number Warning

If the INVALID SERIAL NUMBER message appears, immediately contact Johnson Controls Product Technical Support. The appearance of this message may mean the chiller has lost important factory programmed information. The serial number can be entered using the SERVICE key.

**UNIT WARNING: INVALID SERIAL NUMBER
ENTER UNIT SERIAL NUMBER**

This status message can be bypassed to view additional messages under the STATUS key by pressing the STATUS key repeatedly to scroll through as many as three STATUS messages that could possibly be displayed at any time.

UNIT SAFETIES

Unit Safety Operation

Unit faults are safeties that cause all running compressors to be shut down, if a safety threshold is exceeded for 3 seconds. Unit faults are recorded in the history buffer along with all data on the unit and system operating conditions. Unit faults are auto reset faults where the unit will be allowed to restart automatically after the fault condition is no longer present. The only exception is any of the VSD related unit faults. If any 3 VSD unit faults occur within 90 minutes, the unit will be locked out on the last fault. A VSD lockout condition requires a manual reset using the system switches. Both system switches must be cycled OFF and ON to clear a VSD unit lockout fault. If a unit safety is in effect, the message will be displayed to the operator when the STATUS key is pressed.

In the descriptions of the fault displays that follow, the fault message will show a YYYYYYYY to indicate that a system is in a "FAULT" condition and will restart when the fault clears or LOCKOUT" and will not restart until the operator clears the fault using the keypad.

If a control panel safety occurs after the VSD fault, but before the fault is reset, the control panel fault is an ALL FAULT of the VSD fault, meaning it will be registered as such in the History because it occurred while the VSD was shutting down or while the systems were shut down. All faults do not store operating data at the time of the fault.

If a "VSD" fault occurs during the fault rampdown or while the systems are shut down, the VSD fault will be registered as a new fault. The reason for this is the belief any VSD fault should be registered with a full account of the systems data at the time of the fault.

High Ambient Temp Fault

If the ambient temperature rises above 54°C (130°F), the chiller will shut down with a controlled ramped shutdown. Restart will automatically occur, if demand allows, when temperature falls 1.1°C (2°F) below the cutout (52.9°C [128°F]). This fault cannot cause a lockout. The fault display message will be present only during the time when the ambient temperature is causing a fault condition. A sample display is shown below:

**UNIT YYYYYYYY
HIGH AMBIENT TEMP**

The unit will also be inhibited from starting any time the temperature is above 52.9°C (128°F).

Low Ambient Temp Fault

If the ambient temperature falls below the programmable Low Ambient Temp Cutout the chiller will shut down with a controlled ramped shutdown. This fault will only occur if the Low Ambient Cutout is “ENABLED” under the OPTIONS key. Restart can occur, if demand allows, when temperature rises 1.1°C (2°F) above the cutout. This fault cannot cause a lockout. The fault display message will be present only during the time when the ambient temperature is causing a fault condition. A sample display is shown below:

```
UNIT YYYYYYYY  
LOW AMBIENT TEMP
```

The unit is also inhibited from starting any time the temperature is below the cutout plus 1.1°C (2°F).

Low Leaving Chilled Liquid Temp Fault

The Low Leaving Chilled Liquid Temp Cutout helps to protect the chiller from an evaporator freeze-up should the chilled liquid temp drop below the freeze point. This situation could occur under low flow conditions or if the Micro Panel setpoint values are improperly programmed. Any time the leaving chilled liquid temperature (water or brine) drops below the programmable cutout point, the chiller will fault and shutdown with a controlled ramped shutdown. Restart can occur, if demand allows, when chilled liquid temperature rises 2.2°C (4°F) above the cutout. This fault cannot cause a lockout. A sample shutdown message is shown below:

```
UNIT YYYYYYYY  
LOW LEAVING CHILLED LIQUID TEMP
```

The unit is inhibited from starting any time the chilled liquid temperature is below the cutout plus 2.2°C (4°F).

VSD Communications Failure Fault

The VSD Communications Failure is to prevent the unit from trying to run, if the Chiller Control Board never initializes communications with the VSD Logic Board. The unit will also shut down with a controlled ramped shutdown if the Chiller Control Board loses communications with the VSD Logic Board while the chiller is operating.

On power-up, the Chiller Microprocessor Board will attempt to initialize communications with the VSD Logic Board. The control panel will request data from the VSD, which includes the number of compressors and the VSD software version. Once these data points have been received by the Chiller Control Board, and

have been successfully initialized, the Chiller Control Board will not request them again. If the comms connection fails to occur and a reply from the VSD Logic Board does take place in 8 seconds, the Chiller Control Board will prevent the chiller from operating and a fault message will be displayed.

During normal operation, if the control panel Chiller Control Board receives no valid response to messages for 8 seconds, the unit will shut down all compressors on a Comms fault. The Chiller Control Board will continue to send messages to the VSD while faulted. The unit will be inhibited from starting until communications is established. The fault will automatically reset when the Chiller Control Board receives a valid response from the VSD for a data request. Shown below is an example of a Comms Failure fault message:

```
UNIT YYYYYYYY  
VSD COMMUNICATIONS FAILURE
```

SYSTEM SAFETIES (FAULTS)

System Safety (Fault) Operation

System safeties are faults that cause individual systems to be shut down if a safety threshold is exceeded for 3 seconds. System faults are auto reset faults in that the system will be allowed to restart automatically after the 120 second anti-recycle timer times out. The only exception is after any 3 faults on the same system occur within 90 minutes, that system will be “locked out” on the last fault. The lockout condition requires a manual reset using the system switch. The respective system switch must be cycled OFF and ON to clear the lockout fault.

When multiple systems are operating and a system fault occurs, the running systems will ramp down and the faulted system will be shut OFF and the previously operating will restart if required after the fault clears and/or the 120 second anti-recycle timer times out.

In the descriptions of the fault displays that follow, the fault message will show a YYYYYYYY to indicate that a system is in a “FAULT” condition and will restart when the fault clears, or “LOCKOUT” and will not restart until the operator clears the fault using the keypad. If a system safety is in effect, the message will be displayed to the operator when the STATUS key is pressed.

In some cases, a control panel fault will occur after a VSD fault, possibly during system shutdown or at some later time. This is known as an “ALL FAULT”

and these faults will be recorded as such under the HISTORY information stored at the instant of the primary fault. In some cases, this information may be valuable in troubleshooting the primary fault. An example of the “ALL FAULT” history message is shown on *page 118* under the HISTORY key. When an “ALL FAULT” occurs, associated history information will not be stored. If an additional fault does not occur, the “ALL FAULTS” display will indicate NONE.

In cases where a VSD fault occurs during the ramp-down of a control panel fault (i.e.: low suction pressure, low water temp, etc.), the VSD fault will be stored as a new fault with the associated fault information stored at the instant the VSD fault occurred (i.e.: IGBT Gate Drive, Single Phase Input, VSD CT Plug, etc.). The control panel fault that occurred prior to the VSD fault will be stored with the associated complete data related to the fault as a numerically lower numbered history in the history buffers.

High Discharge Pressure Cutout (Software) Fault

The High Discharge Pressure Cutout is a software fault. A system will fault and shut down with a controlled ramped shutdown on high discharge pressure when the discharge pressure rises above 22.4 barg (325 PSIG) for 0.5 seconds. The system will be allowed to restart when the discharge pressure falls to 20.3 barg (295 PSIG). The system will also be inhibited from starting if the pressure is above 20.3 barg (295 PSIG). The fault message for this safety is shown below:

SYS X YYYYYYYY HIGH DISCHARGE PRESSURE

The X indicates the system and YYYYYYYY indicates the system is in a “FAULT” condition and will restart when the 120 second anti-recycle timer times out, or “LOCKOUT” and will not restart until the operator clears the fault using the keypad.

High Discharge Pressure Cutout (HPCO) (Hardware) Fault

The mechanical High Pressure Cutout protects the system from experiencing dangerously high discharge pressure. A system will fault and shut down immediately when the mechanical high pressure cutout contacts open. The fault will occur immediately and not wait 3 seconds, which is typical of most system faults. The HPCO is wired in series with the VSD Run Signal and will only be checked by the Chiller Control Board

when the system is running. The mechanical cutout opens at 23.2 barg \pm 0.55 barg (337 PSIG \pm 8 PSIG) and closes at 17.4 barg \pm 0.69 barg (252 PSIG \pm 10 PSIG). The Status display fault message for this system is shown below:

SYS X YYYYYYYY HPCO FAULT

The X indicates the system and YYYYYYYY indicates the system is in a “FAULT” condition and will restart when the 120 second anti-recycle timer times out or “LOCKOUT” and will not restart until the operator clears the fault using the keypad.

Low Suction Pressure Cutout (Software) Fault

The programmable Low Suction Pressure Cutout is a secondary back-up for the flow switch and protects against operation with low refrigerant charge, which helps protect the chiller from an evaporator freeze-up, should the system attempt to run with a low refrigerant charge. The Status display fault message for this cutout is shown below:

SYS X YYYYYYYY LOW SUCTION PRESSURE

The X indicates the system and YYYYYYYY indicates the system is in a “FAULT” condition and will restart when the 120 second anti-recycle timer times out or “LOCKOUT” and will not restart until the operator clears the fault using the keypad. Typically, the cutout will be set at 1.65 barg (24 PSIG) for chilled water applications.

The cutout is ignored for the first 30 seconds of system run time. During the next 3 minutes of run time the cutout point is linearly ramped from 10% of the cutout value up to the programmed cutout point. If at any time during the first 3 minutes of operation the suction pressure falls below the ramped cutout point, the system will shut down with a controlled ramped shutdown.

The cutout pressure during operating periods of 30 seconds to 210 seconds is ramped and can be calculated by:

$$\text{Cutout} = \frac{(\text{Programmed Cutout} \times \text{Run Time})}{200} - 1.2 \text{ PSIG}$$

After the first 3 minutes and 30 seconds of run time, if the suction pressure falls below the cutout as a result of a transient in the system, a transient timer is set at 30 seconds and a linearly ramped cutout is set starting at 10% of the programmed cutout. If over the next

30 seconds, the suction pressure does not stay above the ramped cutout, which ramps between 10% of the cutout and the programmed cutout over the 30 second period, the system will fault on low suction pressure.

Low Motor Current Cutout Fault

The Motor Current Cutout shuts the system down with a controlled ramped shutdown when the microprocessor detects the absence of motor current (less than 10% FLA), usually indicating that a compressor is not running. This safety is ignored for the first 10 seconds of operation.

The status display fault message for this safety is shown below:

SYS X YYYYYYYY LOW MOTOR CURRENT

The X indicates the system and YYYYYYYY indicates the system is in a “FAULT” condition and will restart when the 120 second anti-recycle timer times out or “LOCKOUT” and will not restart until the operator clears the fault using the keypad.

High Differential Oil Pressure Cutout Fault

The High Differential Oil Pressure Cutout protects the compressor from low oil flow and insufficient lubrication, possibly from a dirty oil filter. A system will fault and shut down with a controlled ramped shutdown when its Discharge to Oil Differential Pressure rises above the cutout of 4.48 bard (65 PSID). This safety is ignored for the first 90 seconds of run time. This safety measures the pressure differential between discharge and oil pressure, which is the pressure drop across the oil filter. The Status display fault message for this safety is shown below:

SYS X YYYYYYYY HIGH DIFF OIL PRESSURE

The X indicates the system and YYYYYYYY indicates the system is in a “FAULT” condition and will restart when the 120 second anti-recycle timer times out or “LOCKOUT” and will not restart until the operator clears the fault using the keypad.

Low Differential Oil Pressure Cutout Fault

The Low Differential Oil Pressure Cutout protects the compressor from low oil flow and insufficient lubrication. A system will fault and shut down with a controlled ramped shutdown when it’s differential between oil

and suction pressure falls below the cutout. This safety assures that the compressor is pumping sufficiently to push oil through the oil cooling circuit and through the internal compressor lubrication system. The Status display fault message for this safety is shown below:

SYS X YYYYYYYY LOW DIFF OIL PRESSURE

The X indicates the system and YYYYYYYY indicates the system is in a “FAULT” condition and will restart when the 120 second anti-recycle timer times out or “LOCKOUT” and will not restart until the operator clears the fault using the keypad.

The safety is ignored for the first 60 seconds of run time. After the first 60 seconds of operation, the cutout is linearly ramped from 0 bard to 2.09 bard (0 PSID to 30 PSID) in 5 to 10 minutes based on ambient temperature. See the following table for the ramp times for the given ambient temperatures.

TABLE 8 - LOW DIFFERENTIAL OIL PRESSURE CUTOUT

AMBIENT TEMPERATURE	RAMP TIME
more than 10°C (50°F)	5 Minutes
more than 7.2°C (45°F)	6 Minutes
more than 4.4°C (40°F)	7 Minutes
more than 1.6°C (35°F)	8 Minutes
more than 1.1°C (30°F)	9 Minutes
more than or equal to 1.1°C (30°F)	10 Minutes

A 30 second safety bypass below 50 Hertz is employed during rampdown. The bypass is primarily needed under conditions where another compressor is being brought on and the running compressor is being ramped down to 5 Hertz to add the additional compressor due to load requirements. Under these conditions, the slow speed of the running compressor(s) causes the oil differential to become very low, especially if the water temperature is high and the suction pressure is high. The bypass assures the compressor(s) will not trip on a nuisance low oil differential fault.

High Discharge Temperature Cutout Fault

The High Discharge Temperature Cutout protects the motor and compressor from overheating. A system will fault and shut down with a controlled ramped shutdown when its Discharge Temperature rises above 121°C

(250°F). A system will also be inhibited from starting if the discharge temperature is above 93°C (200°F). The Status display fault message for this safety is shown below:

SYS X YYYYYYYY HIGH DISCHARGE TEMP

The X indicates the system and YYYYYYYY indicates the system is in a “FAULT” condition and will restart when the 120 second anti-recycle timer times out or “LOCKOUT” and will not restart until the operator clears the fault using the keypad.

Low Discharge Superheat Cutout Fault

The Low Discharge Superheat safety helps protect the compressor from liquid floodback through the economizer line due to a high flashtank level. It also helps protect the compressor from excessive oil in circulation due to excess oil charge in the system. Excessive oil in circulation brings back liquid refrigerant which is entrained in the oil. The liquid then drops out once it enters the compressor.

The safety is ignored for the first 10 minutes of operation if the system economizer feed valve is closed (0%) and for 5 minutes of operation if the economizer feed valve is open greater than 0%. If the discharge superheat falls below 2.8°C (5.0°F) for 5 minutes under either condition, the system will shut down.

The X indicates the system and YYYYYYYY indicates the system is in a “FAULT” condition and will restart when the 120 second anti-recycle timer times out or “LOCKOUT” and will not restart until the operator clears the fault using the keypad.

Sensor Failure Cutout Fault

The Sensor Failure Cutout prevents the system from running when a critical sensor (transducer, level sensor, or motor winding temp sensor) is not functioning properly and reading out of range. This safety is checked at startup and will prevent the system from running if one of the sensors has failed.

The sensor failure safety will also fault and shutdown a system while in operation, if a safety threshold is exceeded or a sensor reads out of range (high or low). Following is the Status display fault message:

**SYS X YYYYYYYY SENSOR FAILURE:
ZZZZZZZZZZZZ**

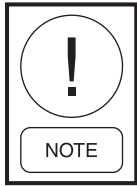

The X indicates the specific system. YYYYYYYY will either indicate the system is in a “FAULT” condition and will restart when the fault clears, or “LOCKOUT” after 3 faults and will not restart until the operator clears the fault using the keypad.

ZZZZZZZZZZZZ indicates the failed sensor below:

- SUCT PRESS
- OIL PRESS
- DSCH PRESS
- MOTOR TEMP X *

*The Unit Setup Mode allows a specific motor temperature sensor to be ignored, if it fails.

The start inhibit thresholds for each sensor are shown in the following table.

TABLE 9 - START INHIBIT SENSOR THRESHOLDS

SENSOR	LOW THRESHOLD	HIGH THRESHOLD
Suction Transducer	0.3VDC	4.7VDC
Oil Transducer	0.3VDC	4.7VDC
Discharge Transducer	0.3VDC	4.7VDC
Motor Temp. Sensor	0°C (0°F)	116°C (240°F)

High Motor Temperature Cutout Fault

The High Motor Temperature Cutout prevents a compressor from running when its motor temperature is too high. A system will fault and shut down when any compressor motor temperature sensor rises above 121°C (250°F). The system will be inhibited from starting if its motor temperatures sensors indicate temperatures above 116°C (240°F). If any single temperature sensor is being ignored under the Unit Set-up Mode, that sensor will not be utilized when evaluating motor temperature.

Below is a sample Status display fault message:

SYS X YYYYYYYY HIGH MOTOR TEMP

The X indicates the system and YYYYYYYY indicates the system is in a “FAULT” condition and will restart when the fault clears or “LOCKOUT” and will not restart until the operator clears the fault using the keypad.

System Control Voltage Cutout Fault

The System Control Voltage Cutout alerts the operator the 115VAC Control voltage to one of the systems is missing. This could be due to a system fuse that has been removed or is blown. The affected system will fault and shut down immediately when the 115VAC supply is lost.

The safety will “not” shut down a system if the UNIT switch is OFF, which electrically removes the 115VAC to “all” systems. The safety is only used to indicate a situation where a single system is missing the 115VAC. The safety will not cause a lockout and the system fault will reset when power is returned. A sample message is shown below:

SYS X YYYYYYYY CONTROL VOLTAGE

The X indicates the system and YYYYYYYY indicates the system is in a “FAULT” condition and will restart when the fault clears or “LOCKOUT” and will not restart until the operator clears the fault using the keypad.

Eductor Clog Fault

To sense a loss of oil return to the compressor, an eductor clog detection safety is utilized. The safety monitors the temperature of the line between the eductor and the suction line.

The control algorithm looks at the eductor line temperature once a second. At start, a clog timer is set at 600 seconds. If the eductor line temperature is less than the saturated suction temperature plus 5.5°C (10°F) each time the control circuit looks at the temperature, the clog timer is reset to 600 seconds.

If the eductor line temperatures is greater than the saturated suction temperature plus 5.5°C (10°F), the clog timer is decremented one second. If the temperature remains above the saturated suction temperature plus 5.5°C (10°F) for 600 seconds, the clog timer will count to “0” and the system will shut down and lock out. The status fault will indicate an eductor clog fault.

EDUCTOR CLOG FAULT

Whenever this fault occurs, the eductor filter should be changed.

The clog timer resets to 600 seconds whenever the control algorithm sees the eductor line temperature is less than the saturated suction pressure plus 5.5°C (10°F). This prevents nuisance eductor clog faults.

THIS PAGE INTENTIONALLY LEFT BLANK.

SECTION 8 - MICROPANEL

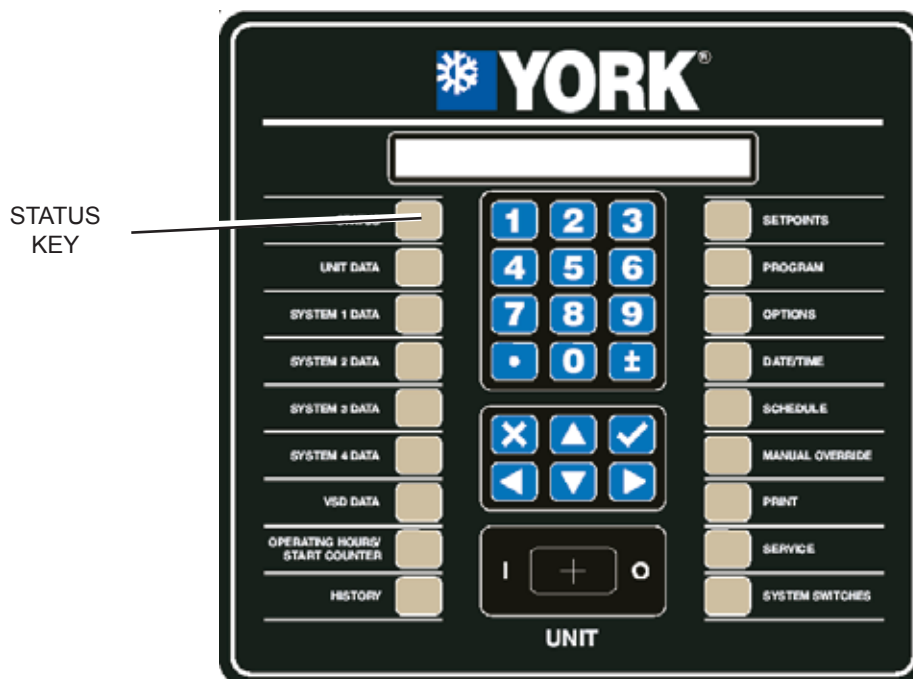

LD10605

STATUS KEY OPERATION

The STATUS key displays the current chiller or system operational status. The messages displayed include running status, cooling demand, system faults, unit faults, VSD faults, unit warnings, external device status, load limiting, anti-recycle timer, status of unit/system switches, and a number of other messages. Pressing the STATUS key will enable the operator to view the current status of the chiller. The display will show one message relating to the “highest priority” information as determined by the microprocessor. There are three types of status data, which may appear on the display:

- General Status messages
- Unit Safeties
- System Safeties.

When power is first applied to the control panel, the following message displaying York International Corporation, the EPROM version, date, and time will be displayed for 2 seconds, followed by the appropriate general status message:

(C)2004 YORK INTERNATIONAL CORPORATION
C.XXX.XX.XX 18-SEPT-2010 12:45: AM

Unit status messages occupy 2 lines of the Status message display. If no unit status message applies, individual status messages for each system will be displayed.

Any time the STATUS key is pressed or after the EPROM message disappears at power-up, a status display indicating chiller or system status will appear.

Multiple STATUS messages may appear and can be viewed by pressing the STATUS key repeatedly to allow scrolling through as many as three STATUS messages, which could possibly be displayed at any time on a 2 compressor chiller.

Examples of the typical Status messages are shown in the next topic

GENERAL STATUS MESSAGES

UNIT STATUS
MANUAL OVERRIDE

This message indicates the chiller is operating in MANUAL OVERRIDE mode. This message is a priority message and cannot be overridden by any other STATUS message. When in Manual Override, no other status message will ever be present.

**UNIT STATUS
UNIT SWITCH OFF SHUTDOWN**

This message indicates the UNIT SWITCH is in the OFF position and not allowing the unit to run.

**UNIT STATUS
DAILY SCHEDULE SHUTDOWN**

This message indicates that either the daily or holiday schedule programmed is keeping the chiller from running.

**UNIT STATUS
REMOTE CONTROLLED SHUTDOWN**

This message indicates that either an ISN or RCC has turned the chiller OFF and is not allowing it to run.

**UNIT STATUS
FLOW SWITCH SHUTDOWN**

This message indicates the flow switch is not allowing the chiller to run. There is a 1 second delay on this safety to assure the flow switch did not momentarily open.

**UNIT STATUS
VSD COOLING SHUTDOWN**

This message indicates the chiller is shutdown, but running all the condenser fans, VSD glycol pump, and VSD fan in an effort to bring the internal VSD ambient temperature down to an acceptable level before allowing the chiller to start.

SYS X REMOTE RUN CONTACT IS OPEN

This message indicates the remote start/stop contact between 2 and 15 or 2 and 16 of the 1TB terminal block is open. There is a 1 second delay on this safety to assure the remote contacts did not momentarily open.

SYS X SYSTEM SWITCH IS OFF

This message indicates the system switch (software via keypad) is turned OFF. The system will not be allowed to run until the system switch is turned ON via the keypad.

SYS X NOT RUNNING

This message indicates the system is not running because the chilled liquid is below the setpoint or the micro has not loaded the lead system far enough into the loading sequence to bring the lag system ON. This

message will be displayed on the lag system until the loading sequence is ready for the lag system to start.

SYS X COOLING DEMAND SHUTDOWN

This message is only displayed in the Normal Shutdown History display to indicate a capacity control shutdown.

SYS X COMPRESSOR RUNNING

This message indicates the system is running as a result of cooling demand.

SYS X SHUTTING DOWN

The compressor shutting down message indicates the respective system is ramping down in speed prior to shutting OFF. This message is displayed after the software run signal is disabled until the VSD notifies the Chiller Control Board the compressor is no longer running.

SYS X ANTI-RECYCLE TIMER = XXX SEC

This message indicates the amount of time left on the respective system anti-recycle timer and the system is unable to start until the timer times out.

SYS X DISCHARGE PRESSURE LIMITING

The Discharge Pressure Limiting message indicates the discharge pressure load limit or discharge pressure unloading is in effect.

SYS X SUCTION PRESSURE LIMITING

The Suction Pressure Limiting message indicates the suction pressure load limit or suction pressure unloading is in effect.

SYS X MOTOR TEMP LIMITING

The Motor Temp Limiting message indicates the motor temp load limit or motor temp unloading is in effect.

SYS X MOTOR CURRENT LIMITING

The motor current limiting message indicates the motor current load limit or motor current unloading is in effect.

SYS X PULLDOWN MOTOR CURRENT LIMITING

The pulldown motor current limiting message indicates the pulldown motor current load limit or pulldown motor current unloading is in effect based on the programmed setpoint.

SYS X ISN CURRENT LIMITING

The ISN Current Limiting message indicates the motor current load limit or motor current unloading is in effect through the use of the YORKTalk setpoint.

SYS X REMOTE MOTOR CURRENT LIMITING

The Remote Motor Current Limiting message indicates the motor current load limit or motor current unloading is in effect through the use of the remote setpoint offset. The setpoint may be offset using a remote voltage or a current signal. The remote current limit must be activated for this function to operate.

SYS X VSD BASEPLATE TEMP LIMITING

The VSD Baseplate Temp Limiting message indicates the VSD Baseplate temp is high and load limit or unloading is in effect.

SYS X VSD INTERNAL AMBIENT TEMP LIMITING

The VSD Internal Ambient Temp Limiting message indicates the VSD internal ambient temp is high and load limit or unloading is in effect.

SYS X SOUND LIMITING

The sound limiting message indicates the sound load limit is in effect based on the locally programmed sound limit from the keypad. The sound limit must be activated for this function to operate.

SYS X ISN SOUND LIMITING

The ISN sound limiting message indicates the sound load limit is in effect based on the ISN transmitted sound limit setpoint. The sound limit must be activated for this function to operate.

SYS X REMOTE SOUND LIMITING

The Remote sound limiting message indicates the sound load limit is in effect based on the Remote controlled sound limit setpoint. The setpoint may be offset using a remote voltage or current signal. The sound limit option must be activated for this function to operate.

UNIT DATA KEY

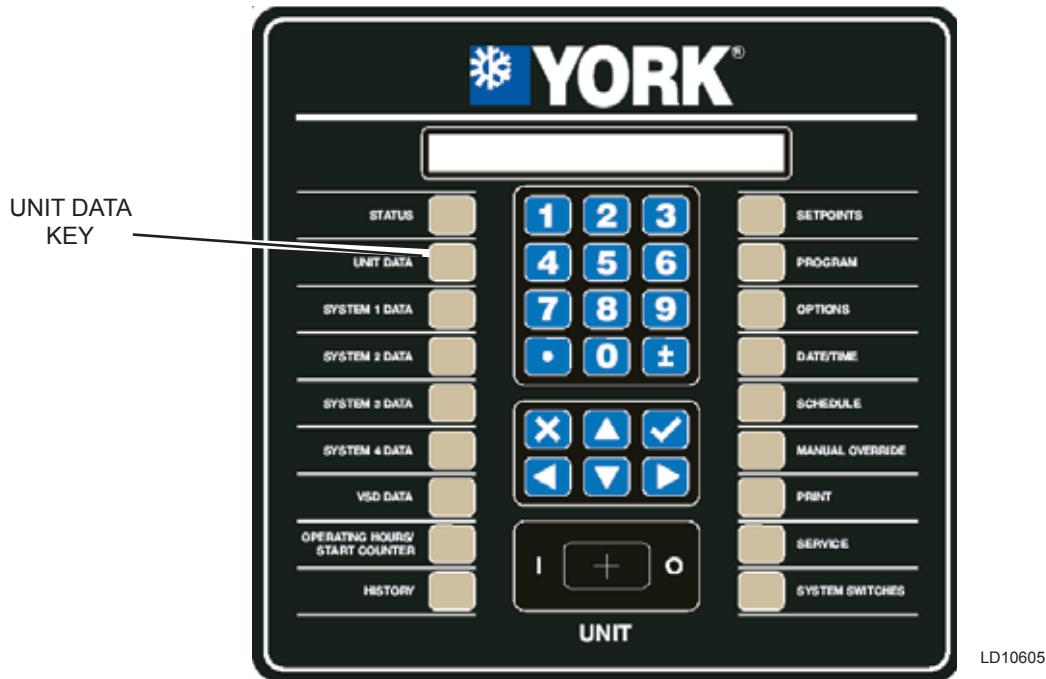

LD10605

General

The UNIT DATA key provides the user with displays of unit temperatures, and unit related data. Displays can be selected by repeatedly pressing the UNIT DATA key or the ▲ or ▼ Arrow Keys.

Unit Data Key Operation

The first key press displays Evaporator Leaving and Return Chilled Liquid Temperatures.

UNIT CHILLED LIQUID LEAVING = XXX.X °F
ENTERING = XXX.X °F

The next key press of the UNIT DATA key or the ▼ (ARROW) key displays the ambient air temperature.

UNIT
OUTSIDE AMBIENT AIR TEMP = XXX.X °F

The next key press will display the time remaining on the load and unload timers.

UNIT
LOAD TIMER = XXX SEC
UNLOAD TIMER = XXX SEC

The next key press displays the error in temperature between the actual leaving chilled liquid temperature and the setpoint temperature. The display also shows the rate of change of the chilled liquid temperature.

UNIT
TEMP ERROR = XXX.X °F
RATE = XXX.X °F/M

The next key press displays the system designated as the lead system and the Flow Switch status (ON or OFF).

UNIT
LEAD SYSTEM NUMBER = X
FLOW SWITCH = XXX

The next key press displays the status of the evaporator pump and heater, where XXX is either ON or OFF.

UNIT
EVAP PUMP RUN = XXX
EVAP HEATER = XXX

The next key press displays the status of Active Remote Control.

UNIT
ACTIVE REMOTE CONTROL = XXXXXX
TYPE: RCC ISN CURR TEMP SOUND

XXXXXX is either ACTIVE or NONE.

If no remote keys are active, the items on the second line are all blanked out. Any remote items that are active will be displayed, while the inactive items will be blanked out.

The types of remote control are listed as follows:

- NONE - No remote control is actively controlling the chiller; however, remote monitoring by a remote device may still be active.
- RCC - A Remote Control Center is providing remote control. The chiller is in remote mode.
- ISN - YorkTalk via ISN. The chiller in remote mode.
- CURR - Remote Current Limiting is enabled.
- TEMP - Remote Temperature Reset is enabled.
- SOUND - Remote Sound Limiting is enabled.

The next key press displays the sound limit values as set under the PROGRAM key by the Local, ISN, and the Remote Sound Limit Inputs. Any sound limits that are inactive will display XXX instead of a numeric value.

UNIT SOUND LIMIT	LOCAL = XXX %
ISN = XXX	REMOTE = XXX %

SYSTEM DATA KEYS 1 THROUGH 4

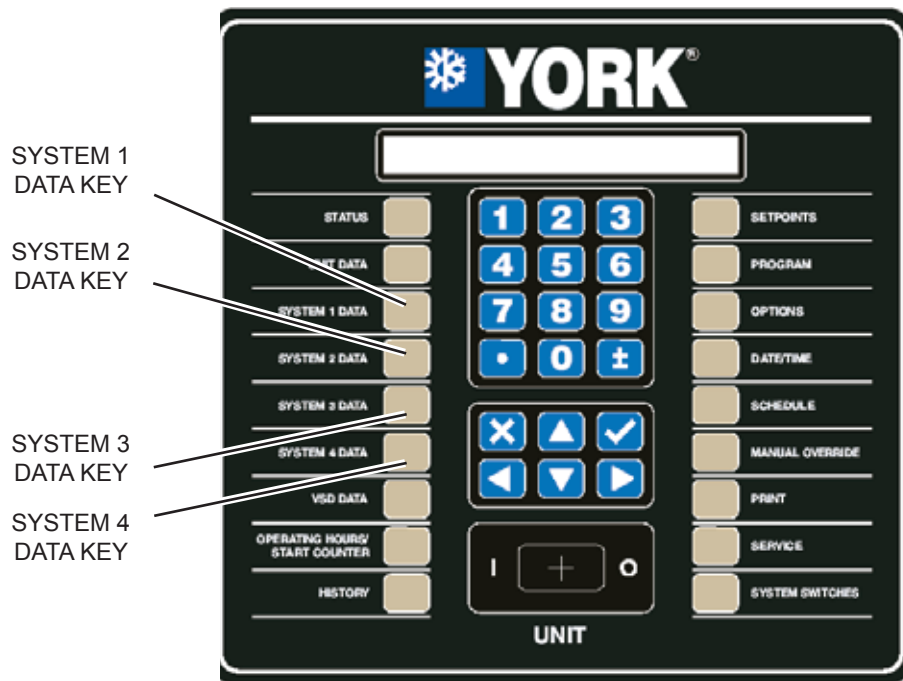

LD10605

General

The data keys provide the user with many displays of individual system temperatures, pressures, and other operating data. These keys have multiple displays, which can be seen by repeatedly pressing the SYSTEM DATA or the ▲ or ▼ (Arrow) keys. An explanation of each key and its messages is provided below.

System 1 Data Key Operation

The SYSTEM 1 DATA key provides the user with access to System 1 operating parameters. The following is a list of the data in the order in which it appears.

The first key press of the SYSTEM X DATA key displays all of the measured system pressures (oil and discharge).

SYS 1 PRESSURES OIL = XXXX PSIG
DISCHARGE = XXXX PSIG

The second key press of the SYSTEM DATA key or the ▼ (DOWN ARROW) key displays system suction and condenser liquid pressure.

SYS 1 PRESSURES SUCTION = XXXX PSIG
CONDENSER LIQUID = XXXX PSIG

The next key press displays system oil and eductor temperatures.

SYS 1 TEMPERATURES OIL = XXX.X °F
EDUCTOR = XXX.X °F

The next key press displays system condenser liquid temperature, liquid line subcooling and saturated discharge temperature on the liquid line.

SYS 1 CONDENSER LIQUID TEMP = XXX.X °F
SUBCOOLING = XXX.X SAT TEMP = XXX.X °F

The next key press displays discharge temperature, discharge superheat and saturated discharge pressure at the compressor.

SYS 1 DISCHARGE TEMP = XXX.X °F
SUPERHEAT = XXX.X SAT TEMP = XXX.X °F

The next key press displays the System 1 motor thermistor temperatures.

SYS 1 MOTOR TEMPS T1 = XXX.X °F
T2 = XXX.X °F T3 = XXX.X °F

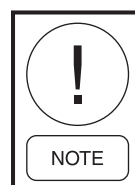

If any motor temp sensor is being ignored, (selectable under Unit Set-up Mode), that sensor's value will be displayed as XXXXX.

Sensor Displays

Table 10 lists all the sensors attached to the control board associated with system data keys. The minimum and maximum values displayed on the micro display are provided.

If values exceed the limits in the table, a < (less than) or > (more than) sign will be display along with the minimum or maximum value.

TABLE 10 - SENSOR MIN/MAX OUTPUTS

SYSTEM SENSOR			
SENSOR / INPUT	TYPE	MINIMUM VALUE	MAXIMUM VALUE
Suction Pressure	Transducer	0.0 PSIG (0 barg)	125.0 PSIG (8.62 barg)
Condenser Liquid Pressure	Transducer	0.0 PSIG (0 barg)	400.0 PSIG (27.6 barg)
Discharge Pressure	Transducer	0.0 PSIG (0 barg)	400.0 PSIG (27.6 barg)
Oil Pressure	Transducer	0.0 PSIG (0 barg)	400.0 PSIG (27.6 barg)
Flash Tank Level	Switch	Low	High
Condenser Liquid Temp	Thermistor	-4.1 °F (-20.06 °C)	155.6 °F (68.67°C)
Leaving Chilled Liquid Temp	Thermistor	-19.1 °F (-28.49°C)	110.2 °F (43.44°C)
Return Chilled Liquid Temp	Thermistor	-19.1 °F (-28.49°C)	110.2° F (43.44°C)
Eductor Temp	Thermistor	-4.1° F (-20.06°C)	132.8 °F (56.00°C)
Ambient Air Temp	Thermistor	-4.6 °F (-20.33°C)	137.9° F (58.83°C)
Compressor Motor Temp	Thermistor	-30.2 °F (-34.56°C)	302.0° F (150.00°C)
Discharge Temp	Thermistor	40.3 °F (4.61°C)	302.6 °F (150.33°C)
Remote Temp Reset	4 to 20ma, 0 to 10VDC, 0 to 20ma or 2 to 10VDC	0%	100%
Remote Current Limit	4 to 20ma, 0 to 10VDC, 0 to 20ma or 2 to 10VDC	0%	100%
Remote Sound Limit	4 to 20ma, 0 to 10VDC, 0 to 20ma or 2 to 10VDC	0%	100%

VSD DATA KEY

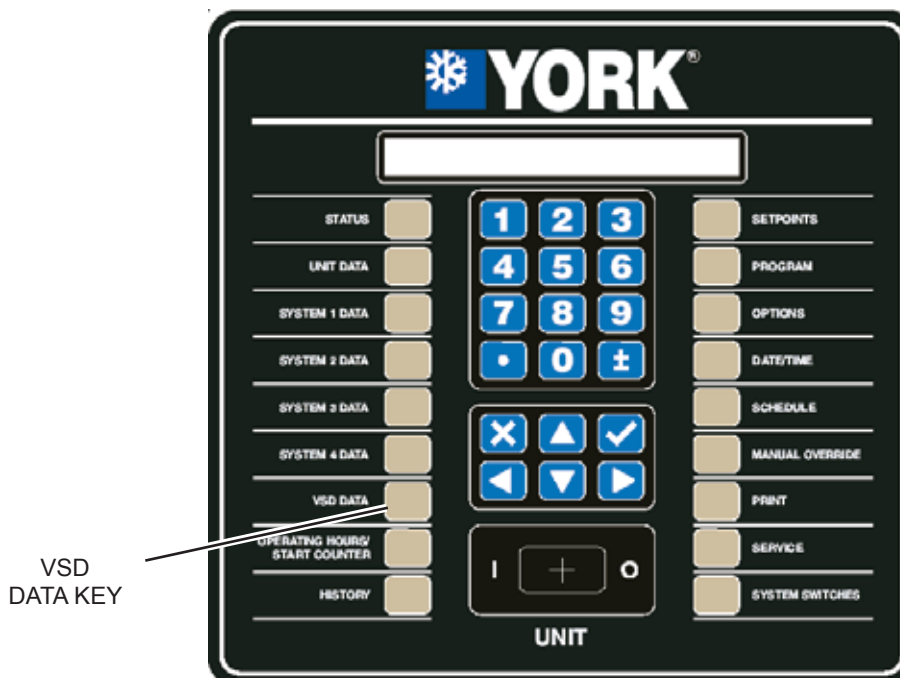

LD10605

8

General

The VSD DATA key provides the user with displays of VSD temperatures, voltages, currents, and other operating data. This key has multiple displays, which can be seen by repeatedly pressing the VSD DATA or the ▲ or ▼ (Arrow) keys. An explanation of each message is provided below.

VSD Data Key Operation

The first VSD DATA key press displays the actual VSD Output Frequency and Command Frequency.

**VSD FREQUENCY ACTUAL = XXX.X HZ
COMMAND = XXX.X HZ**

The second key press of the VSD DATA key or the ▼ (ARROW) key displays the calculated compressor % FLA and measured motor currents in amps for systems 1 and 2. When measuring motor current keep in mind that measuring inverter PWM current is difficult and meter error can be significant.

**VSD COMP 1 = XXX AMPS = XXX %FLA
COMP 2 = XXX AMPS = XXX %FLA**

The next key press displays the current limit values set locally on the panel under the PROGRAM key, remotely by an ISN, and remotely by the Current Limit input. Any current limits that are inactive will display “XXX” instead of a numeric value.

**VSD CURRENT LIMIT LOCAL = XXX %FLA
ISN = XXX REMOTE = XXX %FLA**

The next key press displays DC Bus voltage.

VSD DC BUS VOLTAGE = XXX VDC

The next key press displays the Control Panel/VSD Internal Ambient Temperature and VSD Cooling Pump/Fan Status. YYY will indicate ON or OFF.

**VSD INTERNAL AMBIENT TEMP = XXX.X °F
COOLING SYSTEM STATUS = YYY**

The next key press displays the IGBT highest baseplate temperature.

**VSD IGBT BASEPLATE TEMPS T1 = XXX °F
T2 = XXX °F**

The next key press displays the state of the Precharge signal, where XXX is either ON or OFF.

VSD PRECHARGE SIGNAL = XXX

The next key press displays the setting of the VSD’s 105% FLA overload potentiometer for Compressor #1 and 2. The settings are determined by the adjustment of the overload potentiometers on the VSD Logic Board. These pots are factory set and should not require changing unless the circuit board is replaced.

**VSD COMP 1 MOTOR OVERLOAD = XXX AMPS
COMP 2 MOTOR OVERLOAD = XXX AMPS**

OPERATING HOURS / START COUNTER KEY

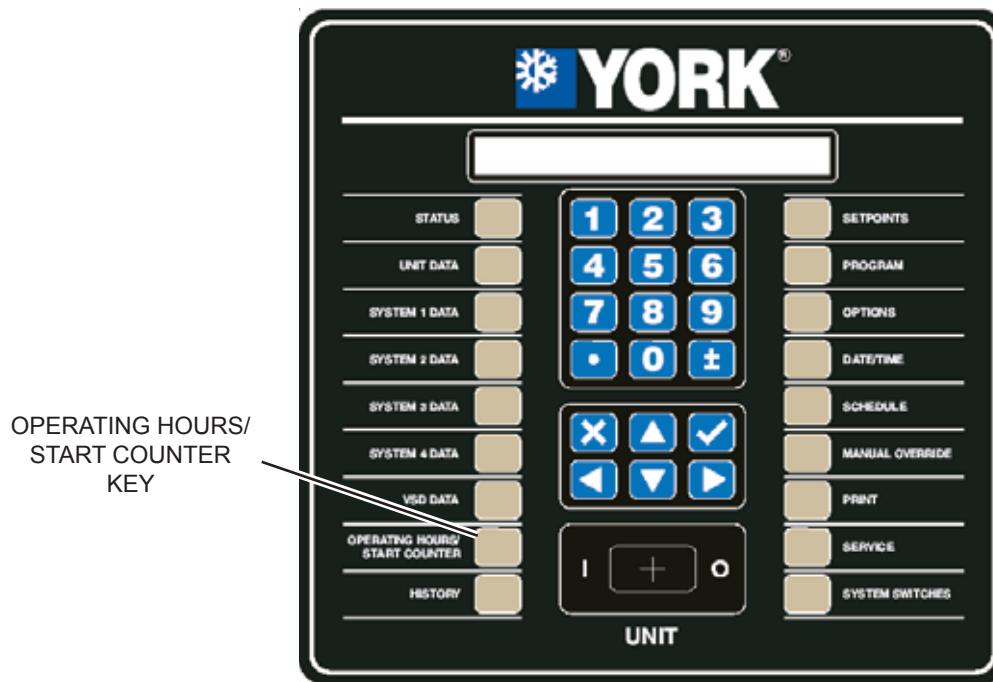

LD10605

Compressor operating hours and compressor starts are displayed with a single key press. The maximum value for both hours and starts is 99,999, at which point they will roll over to 0. A single display is available under this key and is displayed below.

HOURS 1=XXXXX, 2=XXXXX
START 1=XXXXX, 2=XXXXX

HISTORY KEY

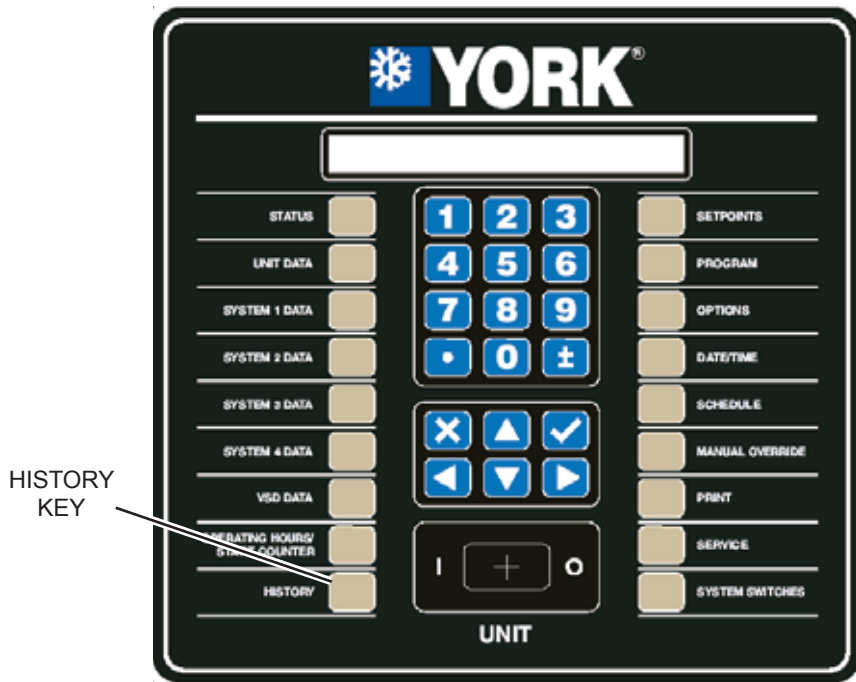

LD10605

History Key Operation

The HISTORY key provides the user access to many unit and system operating parameters captured at the instant a unit or system safety (fault) shutdown occurs. The history buffer will also capture system data at the time of normal shutdowns such as cycling shutdowns. When the HISTORY key is pressed the following screen is displayed:



The ◀ and ▶ (ARROW) keys allow choosing between NORMAL SHUTDOWNS and FAULT SHUTDOWNS. “Fault” shutdowns provide information on safety shutdowns, while “Normal” shutdowns provide chiller cycling information on temperature (demand), cycling, remote, system switch, etc., shutdowns that are non-safety related shutdowns. Once the selection is made, the ✓ (ENTER) key must be pressed to enter the selection.

Normal Shutdowns History

If the NORMAL SHUTDOWNS History is selected, the following screen will be displayed:



XX is the normal shutdown number. The display will provide date and time of the shutdown and the reason for the cycling shutdown (YYY....).

The operator can view any of the stored 20 single display normal shutdown history buffers. History buffer number 1 provides the most recent shutdown information and buffer number 20 is the oldest safety shutdown information saved. The ◀ and ▶ (ARROW) keys allow scrolling between each of the history buffers. The ▶ (ARROW) key scrolls to the next normal history shutdown and the ◀ (ARROW) key scrolls to the previous normal history shutdown.

The following display will typically be displayed on a normal shutdown due to shutdown on lack of cooling demand.



Fault Shutdowns History

If the FAULT SHUTDOWNS History is selected, the following screen will be displayed:



XX is the FAULT HISTORY shutdown number. The display will provide the date, time, and a description of the specific type of fault that occurred (YYY...).

The operator can view any of the stored 10 fault history buffers. History buffer number 1 provides the most recent safety shutdown information and buffer number 10 is the oldest safety shutdown information saved. The ◀ and ▶ arrow keys allow scrolling between each of the FAULT HIST buffers 1 through 10. The ▲ (UP) and ▼ (DOWN) arrow keys can be used to scroll forwards and backwards through the data in a specific history buffer, once it is displayed.

There is a large amount of data provided under each history. Rather than scroll sequentially through the data in a history, which is possible using the ▼ arrow key, the use of a combination of the ◀, ▶, ▲, and ▼ arrow keys allows fast scrolling to specific data the user desires to view. To use this feature, the user needs to be aware the ◀ and ▶ arrow keys allow scrolling to the top of the data subgroups. Once a specific history is selected, the history data is divided under the subgroups of Unit Data, VSD Data, System Data, Hours/Starts, Setpoints, Options, and Program data. The ◀ and ▶ arrow keys allow moving to the first display under the next or previous subgroup at any time. Once the first display of a subgroup is displayed, the ▲, and ▼ arrow keys allow scrolling through the data in the subgroup. The ▼ arrow key allows scrolling through the data from first to last. When the last piece of data is displayed, the next press of the ▼ arrow key scrolls to the first piece of data in the next subgroup. The ▲ arrow key allows going to the previous display.

Listed below is a description of the fault data displays and their meaning. Data will be displayed in a specific order starting with the Status Display (System Faults only), Fault Display, All Fault Display, Unit Data, VSD Data, System Data, Operating Hours/Starts, Setpoints, Options, and Program Values at the time of the fault.

Status Fault Type

```
SYS X COMPRESSOR RUNNING
SYS X YYYYYYYY HIGH DIFF OIL PRESSURE
```

This message indicates the type of system fault. This screen is skipped if a UNIT Fault caused the shutdown.

Unit Fault Type

```
UNIT FAULT
LOW AMBIENT TEMP
```

This message indicates the type of unit fault. This screen is skipped if a SYSTEM Fault caused the shutdown.

All Fault Data

```
FAULT HIST XX ALL FAULTS ZZ OF WW
YYYYYYYYYYYYYYYYYYYYYYYYYYYYYYYYYYYYYYYY
```

The ALL FAULT display indicates whether a fault occurred while the unit is shutting down on another fault.

If a control panel fault occurred while the unit is shutting down on a VSD fault before it is reset, the control panel fault is an ALL FAULT of the VSD fault.

If another VSD fault occurs while the unit is shutting down on a VSD fault, the next VSD fault will be registered as an ALL FAULT of the VSD fault.

If a VSD fault occurs during the ramp down shutdown of a control panel fault, the VSD fault is registered as a new fault, not an ALL FAULT

XX is the history number, YYY is the ALL FAULT description, ZZ is the ALL FAULT number and WW is the total number of All Faults for the current history. Sometimes, multiple faults may occur during the shutdown and multiple displays will be observed when scrolling through the data using the ▼ arrow. In most cases, the ALL FAULT display will indicate NONE. The ALL FAULT display will only indicate the cause of the fault. No additional chiller information will be displayed under the ALL FAULT, since a snapshot of all chiller data was taken at the time of the first fault.

Unit Data

Evaporator Leaving and Entering Chilled Liquid Temperatures

```
UNIT CHILLED LIQUID LEAVING = XXX.X °F
ENTERING = XXX.X °F
```

This message indicates the leaving and entering chilled liquid temperatures at the time of the fault.

Ambient Air Temperature

UNIT
OUTSIDE AMBIENT AIR TEMP = XXX.X °F

This message indicates the ambient air temperature at the time of the fault.

Load / Unload Timers

UNIT LOAD TIMER = XXX SEC
 UNLOAD TIMER = XXX SEC

This message indicates remaining time on the load and unload timers at the time of the fault.

Chilled Liquid Temperature Error and Rate of Change

UNIT TEMP ERROR = XXX.X °F
 RATE = XXX.X °F/M

This message indicates the temperature error between the actual and the programmed setpoint at the time of the fault and the rate of temperature change.

Programmed Lead System Selection and Flow Switch Status

UNIT LEAD SYSTEM NUMBER = X
 FLOW SWITCH = XXX

This message indicates the designated lead system at the time of the fault and whether the flow switch was ON (Closed) or OFF (Open) at the time of the fault.

Evaporator Pump and Evaporator Heater Status

UNIT EVAP PUMP RUN = XXX
 EVAP HEATER = XXX

This message indicates the status of the evaporator pump and the evaporator heater at the time of the fault. XXX indicates ON or OFF.

Active Remote Control Status

UNIT ACTIVE REMOTE CONTROL = XXXXXX

This message indicates whether the system was operating under Active Remote Control (RCC, ISN, LOAD, TEMP, or SOUND) or standard control (NONE) at the time of the fault.

UNIT SOUND LIMIT LOCAL = XXX %
 ISN = XXX REMOTE = XXX %

This message indicates that sound limiting was in effect, the amount, and whether it was local or remotely limited.

VSD Data

VSD Actual and Command Frequency

VSD FREQUENCY ACTUAL = XXX.X HZ
 COMMAND = XXX.X HZ

This message indicates the VSD actual operating frequency and the command frequency at the time of the fault. Actual and command may not match due to load/unload timers, limitation of 1 Hz per load/unload increment, and to allowable acceleration/deceleration of the motor.

Compressor Amps and %FLA

The message indicates the compressor %FLA and motor currents for systems 1 and 2 at the time of the fault.

COMP 1 = XXX AMPS = XXX %FLA
COMP 2 = XXX AMPS = XXX %FLA

VSD Current Limit

VSD CURRENT LIMIT LOCAL = XXX %FLA
 ISN = XXX REMOTE = XXX %FLA

This message displays the current limit values as set locally, by an ISN, or a remote current limiting input at the time of the fault.

DC BUS Voltage

VSD DC BUS VOLTAGE = XXX VDC

This message displays the DC Bus voltage at the time of the fault.

VSD Internal Ambient Temp

VSD INTERNAL AMBIENT TEMP = XXX.X °F
 COOLING SYSTEM STATUS = YYY

This message displays the VSD/Microprocessor internal ambient cabinet temperature and the cooling system status (ON or OFF) at the time of the fault.

8

IGBT Baseplate Temperature

VSD IGBT BASEPLATE TEMPS T1 = XXX °F
T2 = XXX °F

This message displays the IGBT highest baseplate temperature for 2 and 3 compressor units at the time of the fault. 4 compressor units display temperatures for 1/3 (T1) and 2/4 (T2).

Precharge Signal Status and VSD Cooling Status

VSD PRECHARGE SIGNAL = XXX

This display provides the state of the precharge signal, where XXX is either ON or OFF at the time of the fault.

Compressor #1 and #2, 105% FLA Motor Overload Current Setting

VSD COMP 1 MOTOR OVERLOAD = XXX AMPS
COMP 2 MOTOR OVERLOAD = XXX AMPS

This message displays the setting of the VSD's 100% FLA potentiometer for Compressor #1 and #2 at the time of the fault.

System Data**System #1 Pressures**

SYS 1 PRESSURES OIL = XXXX PSIG
DISCHARGE = XXXX PSIG

This message displays the measured system oil and discharge pressures at the time of the fault.

SYS 1 PRESSURES SUCTION = XXXX PSIG
CONDENSER LIQUID = XXXX PSIG

This message displays the measured system suction and condenser liquid line pressure at the time of the fault.

System # 1 Temperatures

SYS 1 TEMPERATURES OIL = XXX.X °F
EDUCTOR = XXX.X °F

This message displays the measured system oil and eductor temperatures at the time of the fault.

SYS 1 CONDENSER LIQUID TEMP = XXX.X °F
SUBCOOLING = XXX.X SAT TEMP = XXX.X °F

This message displays the condenser liquid, liquid line subcooling and saturated discharge temperatures at the time of the fault.

SYS 1 DISCHARGE TEMP = XXX.X °F
SUPERHEAT = XXX.X SAT TEMP = XXX.X °F

This message displays the system discharge, discharge superheat and saturated discharge temperatures at the time of the fault.

Compressor Speed and Heater Status

SYS 1 COMPRESSOR SPEED = XXX.X %
HEATER = XXX.X °F

This message indicates the compressor speed in % and the heater status at the time of the fault.

System #1 Motor Temperatures

SYS 1 MOTOR TEMPS T1 = XXX.X °F
T2 = XXX.X T3 = XXX.X °F

This message displays the System 1 motor thermistor temperatures at the time of the fault.

Flash Tank Level and Economizer Position

SYS 1 FLASH TANK LEVEL Y 512 ADC
ECONOMIZER VALVE = XXX.X %

This message displays the flash tank level and the economizer valve position in % at the time of the fault.

Condenser Subcooling and Condenser Drain Valve Position

SYS 1 CONDENSER SUBCOOLING = XXX.X °F
CONDENSER DRAIN VALVE = XXX.X %

This message displays the condenser subcooling and the Condenser Drain Valve position at the time of the fault.

Condenser Fans

SYS 1 CONDENSER FANS ON = X

**SYS 1 CONDENSER FANS ON = X
VSD FAN SPEED XX.X V = XXX %**

This message displays the number of condenser fans ON or the optional VSD fan control speed signal to the inverter and the % of full speed.

VI Step Solenoid

**SYS 1 VI STEP SOLENOID 1 = XXX
VI STEP SOLENOID 2 = XXX**

This message displays whether the VI solenoids were ON or OFF at the time of the fault.

Compressor #1 Run Time

**SYS 1 RUN TIME
XX DAYS XX HOURS XX MINUTES XX SECONDS**

This message displays the system run time since the last start in days, hours, minutes, and seconds at the time of the fault.

System #1 Run Signals

**SYS 1 RUN SIGNALS RELAY = XXX
RUN PERM = XXX SOFTWARE = XXX**

This message displays the System Run Signal Relay (Relay Output Board) status, Run Permissive Input status, and the Internal Software (microprocessor command) ON/OFF Start status. The status of each will indicate either ON or OFF.

System 2 Data

Data for the system 2 at the time of the fault is displayed in the same sequence as the system #1 data.

Compressor Operating Hours and Starts

**HOURS 1=XXXXX, 2=XXXXX
START 1=XXXXX, 2=XXXXX**

This message displays compressor operating hours and compressor starts at the time of the fault.

Chilled Liquid Setpoint Cooling Setpoints

**SETPOINTS
LOCAL COOLING SETPOINT = XXX.X °F**

This message displays the programmed cooling setpoint at the time of the fault.

**SETPOINTS
LOCAL CONTROL RANGE = +/- X.X °F**

This message displays the programmed Control Range at the time of the fault.

Remote Setpoint and Range

**SETPOINTS REMOTE SETPOINT = XXX.X °F
REMOTE CONTROL RANGE = +/- X.X °F**

This message displays the remote setpoint and Control Range at the time of the fault.

Maximum Remote Temperature Setpoint

**SETPOINTS
MAXIMUM REMOTE TEMP RESET = XXX.X °F**

This message displays the maximum remote reset programmed at the time of the fault.

Options

Display Language

**OPTIONS DISPLAY LANGUAGE
◀ ▶ XXXXXXXXXXXXXXXXXXXXXXXX**

This message displays the language selected at the time of the fault.

Chilled Liquid Cooling Mode

**OPTIONS CHILLED LIQUID COOLING MODE
◀ ▶ WATER COOLING**

This message displays the chilled liquid temperature mode (water or glycol) selected at the time of the fault.

Local / Remote Control Mode

**OPTIONS CHILLED LIQUID COOLING MODE
◀ ▶ GLYCOL COOLING**

This message indicates whether Local or Remote Control Mode was selected at the time of the fault.

**OPTIONS LOCAL / REMOTE CONTROL MODE
◀ ▶ XXXXXXXXXXXXXXXXXXXXXXXX**

When Remote Control Mode is selected, control of the Chilled Liquid Setpoint is from a remote device such as an ISN/BAS controller.

Display Units Mode

```

OPTIONS  DISPLAY UNITS
◀ ▶      XXXXXXXXXXXXXXXXXXXXXXXX
    
```

This message indicates whether SI (°C, barg) or Imperial units (°F, PSIG) was selected at the time of the fault.

System Lead/Lag Control Mode

```

OPTIONS  LEAD / LAG CONTROL MODE
◀ ▶      XXXXXXXXXXXXXXXXXXXXXXXX
    
```

This message indicates the type of lead lag control selected at the time of the fault. Three choices are available:

- Automatic
- Sys 1 Lead
- Sys 2 Lead

The default mode will be AUTOMATIC.

Remote Temperature Reset

```

OPTIONS  REMOTE TEMP RESET INPUT
◀ ▶      XXXXXXXX
    
```

This message indicates whether temperature reset was active or disabled at the chiller keypad at the time of the fault and if active, the type of reset signal selected.

If the option is not factory enabled, the option will not appear.

Remote Current Reset

```

OPTIONS  REMOTE CURRENT LIMIT INPUT
◀ ▶      XXXXXXXXXXXX
    
```

This message indicates whether remote current reset was active or disabled at the chiller keypad at the time of the fault and if active, the type of reset signal selected.

If the option is not factory enabled, the option will not appear.

Remote Sound Limit Selection

```

OPTIONS  REMOTE SOUND LIMIT INPUT
◀ ▶      XXXXXXXXXXXX
    
```

This message indicates whether remote sound limit was active or disabled at the chiller keypad at the time of the fault and if active, the type of reset signal selected.

If the option is not factory enabled, the option will not appear.

Program Values

Suction Pressure Cutout

```

PROGRAM
SUCTION PRESSURE CUTOUT = XXX.X PSIG
    
```

This message indicates the suction pressure cutout programmed at the time of the fault.

Low Ambient Cutout

```

PROGRAM
LOW AMBIENT TEMP CUTOUT = XXX.X °F
    
```

This message displays the low ambient temp cutout programmed at the time of the fault.

Low Leaving Chilled Liquid Temp Cutout

```

PROGRAM
LEAVING LIQUID TEMP CUTOUT = XXX.X °F
    
```

This message displays the low leaving chilled liquid temperature cutout programmed at the time of the fault.

Motor Current Limit

```

PROGRAM
MOTOR CURRENT LIMIT      = XXX %FLA
    
```

This message indicates the motor current limit programmed at the time of the fault.

Pulldown Current Limit

```

PROGRAM
PULLDOWN CURRENT LIMIT  = XXX %FLA
    
```

This message indicates the pulldown current limit programmed at the time of the fault.

Pulldown Current Limit Time

```

PROGRAM
PULLDOWN CURRENT LIMIT TIME = XXX MIN
    
```

This message indicates the pulldown current limit time programmed at the time of the fault.

Condenser Subcooling Setpoint

```

PROGRAM
SUBCOOLING SETPOINT      = XXX.X °F
    
```

This message indicates the liquid subcooling setpoint programmed at the time of the fault.

Unit ID Number

```
PROGRAM  
REMOTE UNIT ID NUMBER = X
```

This indicates the unit ID # programmed at the time of the fault.

Sound Limit Setpoint

```
PROGRAM  
SOUND LIMIT SETPOINT = XXX %
```

This indicates the sound limit setpoint programmed at the time of the fault, if the sound limit option is activated at the factory. If the option is not factory activated, the display will not appear.

Eductor Differential Temperature

```
PROGRAM ◀DEF XXXXX LO XXXXX HI XXXXX  
EDUCTOR DIFFERENTIAL = XXX °F
```

This message indicates the programmed eductor differential temperature at the time of the fault.

Eductor Safety Time

```
PROGRAM ◀DEF XXXXX LO XXXXX HI XXXXX  
EDUCTOR SAFETY TIME = XXX MIN
```

This message indicates the eductor safety time programmed at the time of the fault.

Motor Temperature Unload

```
PROGRAM ◀DEF XXXXX LO XXXXX HI XXXXX  
MOTOR TEMPERATURE UNLOAD = XXX °F
```

This message indicates the motor temperature programmed at the time of the fault.

SETPOINTS KEY

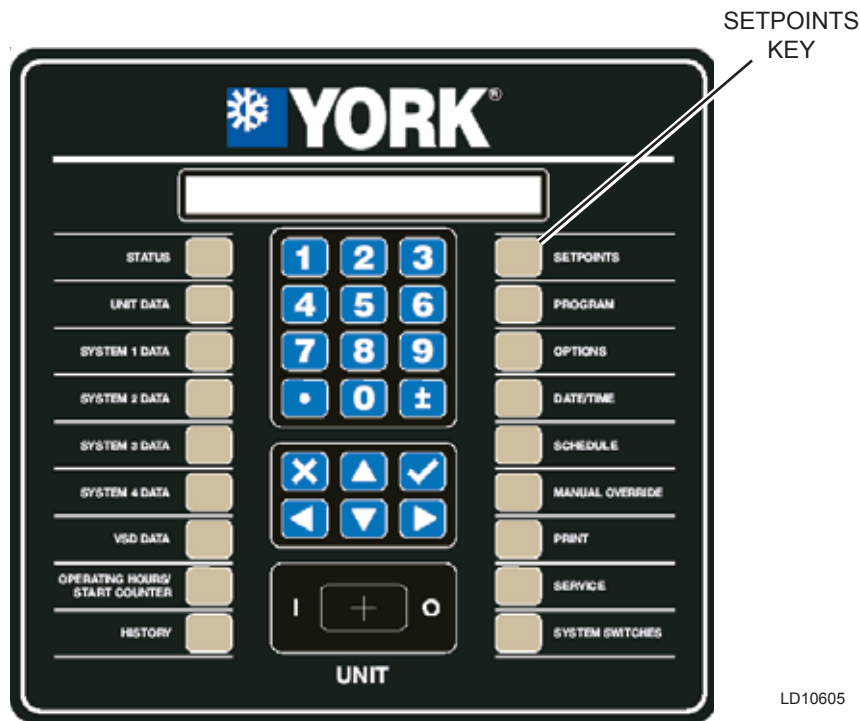

LD10605

Setpoints Key Operation

Cooling setpoints and ranges may be programmed by pressing the SETPOINTS key. The first setpoint entry screen will be displayed as shown below. The first line of the display will show the chiller default (DEF), minimum acceptable value (LO) and maximum acceptable value (HI). The second line shows the actual programmed value. Table 11 also shows the allowable ranges for the cooling setpoints and Control Ranges. Note that the Imperial units are exact values while the Metric units are only approximate.

**SETPOINTS ◀DEF XXXXX LO XXXXX HI XXXXX
LOCAL COOLING SETPOINT = XXX.X °F**

Pressing the SETPOINTS key a second time or the ▼ (ARROW) key will display the leaving chilled liquid Control Range, default, and low/high limits.

**SETPOINTS ◀DEF XXXXX LO XXXXX HI XXXXX
LOCAL CONTROL RANGE = +/- X.X °F**

Pressing the SETPOINTS key or the ▼ (ARROW) key a third time will display the remote setpoint and cooling range. This display automatically updates about every 2 seconds. This remote setpoint message is show below:

**SETPOINTS REMOTE SETPOINT = XXX.X °F
REMOTE CONTROL RANGE = +/- X.X °F**

If there is no remote setpoint being utilized, the remote setpoint value will be displayed as XXXXXX and the remote Control Range will display XXX.

Pressing the SETPOINTS key or the Arrow key a fourth time will bring up a screen that allows the Maximum Remote Temperature Reset to be programmed. This message is show below:

**SETPOINTS ◀DEF XXXXX LO XXXXX HI XXXXX
MAXIMUM REMOTE TEMP RESET = XXX.X °F**

The values displayed under each of the key presses may be changed by keying in new values and pressing the ✓ (ENTER) key to store the new value into memory. Where more than one value may be keyed in on a display, a portion of the data that does not need updating may be skipped by pressing the ✓ (ENTER) key. The ✓ (ENTER) key must also be pressed after the last value in the display to store the data into memory.

The ▲ (ARROW) key allows scrolling back through the setpoints displays.

The minimum, maximum, and default values allowed under the SETPOINTS key are provided in the following table.

TABLE 11 - SETPOINT LIMITS

PROGRAM VALUE	MODE	LOW LIMIT	HIGH LIMIT	DEFAULT
Leaving Chilled Liquid Setpoint	Water Cooling	40.0°F	60.0°F	44.0°F
		4.4°C	15.6°C	6.7°C
	Glycol Cooling	15.0°F	70.0°F	44.0°F
		-9.4°C	15.6°C	6.7°C
Leaving Chilled Liquid Control Range	-	1.5°F	2.5°F	2.0°F
		0.8°C	1.4°C	1.1°C
Max. Remote Temperature Reset	-	2°F	40°F	20°F
		1°C	22°C	11°C

PROGRAM KEY

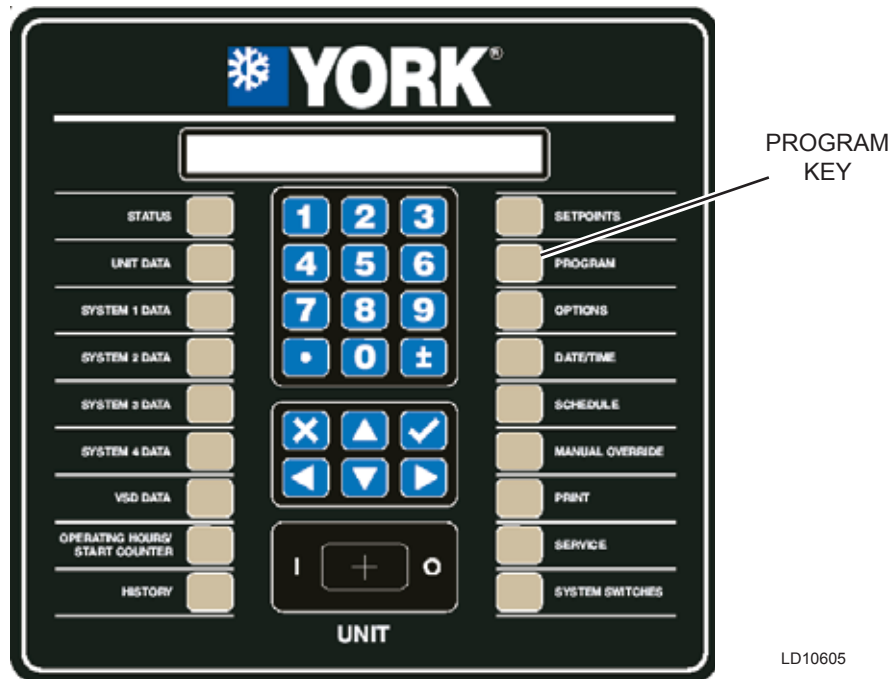

LD10605

Program Key Operation

Various operating parameters are programmable by the user. These are modified by pressing the PROGRAM key and then the ✓ (ENTER) key to enter Program Mode. A listing of the limits of the programmable values is found below. Note that the Imperial units are exact values, while Metric units are only approximate.

The ▲ and ▼ (ARROW) keys are used to scroll through the user programmable values. A value may be changed by keying in the new value and pressing the ✓ (ENTER) key to store the new value in memory. The cursor will be displayed on the screen when a number key is pressed. The first line of each message will indicate the chiller default (DEF) value), lowest acceptable programmable value (LO), and highest acceptable programmable value (HI). The user programmable value is programmed ON in the second line of the message.

When the PROGRAM key is first pressed, the following display will appear indicating the user is in the program mode:

```
PROGRAM MODE XXXX
PRESS ENTER KEY TO CONTINUE
```

Pressing the ✓ (ENTER) key again will display the first programmable selection.

Suction Pressure Cutout

```
PROGRAM ◀DEF XXXXX LO XXXXX HI XXXXX
SUCTION PRESSURE CUTOUT = XXX.X PSIG
```

The suction pressure cutout protects the chiller from a low refrigerant condition. It also helps protect from a freeze-up due to low or no chilled liquid flow. However, it is only a back-up for a flow switch and cannot protect against an evaporator freeze under many conditions. This cutout is programmable and should generally be programmed for 1.65 barg (24 PSIG) for chilled water cooling.

The cutout is programmable between 1.65 and 2.48 barg (24.0 and 36.0 PSIG) in the Water Cooling mode and 0.34 and 2.28 barg (5.0 and 36.0 PSIG) in the Glycol Cooling mode. The default value for both modes will be 1.65 barg (24.0 PSIG).

Low Ambient Cutout

```
PROGRAM ◀DEF XXXXX LO XXXXX HI XXXXX
LOW AMBIENT TEMP CUTOUT = XXX.X °F
```

The low ambient temp cutout allows programming the outdoor temperature at which it is desired to shut down the chiller to utilize other methods of cooling.

The cutout is programmable between -18.9°C (-2.0°F) and 10.0°C (50°F) with a -3.9°C (25°F) default.

Low Leaving Liquid Temp Cutout

PROGRAM ◀DEF XXXXX LO XXXXX HI XXXXX
LEAVING LIQUID TEMP CUTOUT = XXX.X °F

The leaving chilled liquid temp cutout is programmed to avoid freezing the evaporator due to excessively low chilled liquid temperatures. The cutout is automatically set at 2.2 °C (36°F) in the Water Cooling mode and is programmable in the Glycol Cooling mode. In the Glycol Cooling Mode, the cutout is programmable from -11.7°C to 2.2°C (11.0°F to 36.0°F) with a default of 2.2°C (36.0°F).

Motor Current Limit

PROGRAM ◀DEF XXXXX LO XXXXX HI XXXXX
MOTOR CURRENT LIMIT = XXX % FLA

The motor current limit %FLA is programmable. This allows the microprocessor to limit a system before it faults on high current. Typically, the limit point is set at 100%. The unload point is programmable from 30 to 100% with a default of 100%.

Pulldown Current Limit

PROGRAM ◀DEF XXXXX LO XXXXX HI XXXXX
PULLDOWN CURRENT LIMIT = XXX % FLA

The pulldown current limit %FLA is programmable. This allows the microprocessor to limit a system on pulldown limiting for the purpose of peak time energy savings. Typically, the limit point is set at 100%. The pulldown limit point is programmable from 30 to 100% with a default of 100%. Be aware when using pulldown motor current limit, the chiller may not be able to load to satisfy temperature demand

Pulldown Current Limit Time

PROGRAM ◀DEF XXXXX LO XXXXX HI XXXXX
PULLDOWN CURRENT LIMIT TIME = XXX MIN

The pulldown current limit time is programmable. This allows the microprocessor to limit a system on pulldown limiting for a defined period of time for the purpose of peak time energy savings. The pulldown limit point is programmable from 0 to 255 with a default of 0 Min.

Subcooling Setpoint

PROGRAM ◀DEF XXXXX LO XXXXX HI XXXXX
SUBCOOLING SETPOINT = XXX.X °F

The liquid subcooling superheat setpoint is programmable from 0.0 to 11.1°C (0.0 to 20.0°F) with a 2.8°C (5.0°F) default. Typically the subcooling control will be programmed for 2.8°C (5.0 °F).

Unit ID Number

PROGRAM ◀DEF XXXXX LO XXXXX HI XXXXX
REMOTE UNIT ID NUMBER = X

For purposes of remote communications, multiple chillers may be connected to an RS-485 communications bus. To allow communications to each chiller, a chiller ID number may be programmed into memory. On a single chiller application, the value will be “0”.

Sound Limit Setpoint

PROGRAM ◀DEF XXXXX LO XXXXX HI XXXXX
SOUND LIMIT SETPOINT = XXX %

The sound limit setpoint is programmable from 0 to 100 % with a 0% default. 0% allows operating up to the full speed capability of the unit with no sound limiting. Typically the sound limit control setting will be programmed for 0 % unless sound limiting is utilized on the chiller. Sound limiting will only permit the unit to run to a frequency less than the maximum speed capability of the unit. Programming a value of 1% would be the minimum sound limiting that can be programmed and 100% will be the maximum. 100% will only allow the unit speed to operate at the minimum frequency. Usually, the sound limit % will be programmed somewhere between 0 and 100% according the limiting needed to satisfy the sound requirements of the site. Typically, sound limiting will be utilized in areas sensitive to noise during night-time hours. The sound limit display will only be present if the sound limit option is programmed at the factory.

Eductor Differential

PROGRAM ◀DEF XXXXX LO XXXXX HI XXXXX
EDUCTOR DIFFERENTIAL = XXX °F

The eductor temperature differential is programmable from 0°C to 10.0°C (0°F to 50.0°F). The default value is 5.0°F. The programmed temperature assures the micro will sense a loss of educator oil flow, if the temperature differential rises. A small differential of 2.8°C (5.0°F) is recommended.

Eductor Safety Time

PROGRAM ◀DEF XXXXX LO XXXXX HI XXXXX
EDUCTOR SAFETY TIME = XXXX MIN

The educator safety time allows programming the time period the system is permitted to run if the safety threshold is exceeded. The safety time is programmable for 10 minutes to 1000 minutes with 10 minutes as the default. A minimum safety time is recommended to assure the compressor is not starved for oil for long periods of time due to the educator circuit not siphoning oil from the evaporator. A minimum time of 10 minutes is recommended as the program point.

Motor Temperature Unload

PROGRAM ◀DEF XXXXX LO XXXXX HI XXXXX
MOTOR TEMPERATURE UNLOAD = XXX °F

The motor temperature unload is programmable from 65.6°C (150.0°F) to 121.1°C 250.0°F. The default value is 115.5°C (240.0°F). The programmed temperature assures the micro will sense a rise in motor temperature due to a lack of compressor cooling. If the temperature rises above the programmed threshold, the system will unload the compressor by reducing speed. An unload temperature of 115.5°C (240.0°F) is recommended to assure the system does provides maximum capacity.

Default Values

A listing of the low limits, high limits, and default values for each of the programmable values is noted in each display and can be found in Table 12. Note that the Imperial units are exact values while the Metric units are only approximate.

TABLE 12 - PROGRAMMABLE OPERATING PARAMETERS

PROGRAM VALUE	MODE	LOW LIMIT	HIGH LIMIT	DEFAULT
Suction Pressure Cutout	Water Cooling	24.0 PSIG	36.0 PSIG	24.0 PSIG
		1.65 barg	2.48 barg	1.65 barg
	Glycol Cooling	5.0 PSIG	36.0 PSIG	24.0 PSIG
		0.34 barg	2.48 barg	1.65 barg
Low Ambient Temp. Cutout	-	-2.0°F	50.0°F	25.0°F
		-18.9°C	10.0°C	-3.9°C
Leaving Chilled Liquid Temp. Cutout	Water Cooling	-	-	36.0°F
		-	-	2.2°C
	Glycol Cooling	11.0°F	36.0°F	36.0°F
		-11.7°C	2.2°C	2.2°C
Motor Current Limit	-	30% FLA	103% FLA	103% FLA
Pulldown Motor Current Limit	-	30% FLA	100% FLA	100% FLA
Pulldown Motor Current Limit Time	-	0 Min	255 Min	0 Min
Condenser Subcooling Setpoint	-	0.0°F	20.0°F	5.0°F
		0.0°C	11.1°C	2.8°C
Unit ID Number	-	0	7	0
Sound Limit Setpoint	Sound Limit Option Enabled	0%	100%	0%
Eductor Temp Differential	-	5.0°F	50.0°F	15.0°F
		2.77°C	27.8°C	8.3°C
Eductor Safety Time	-	10 Min	1000 Min	30 Min*
Motor Temperature Unload	-	150.0°F	250.0°F	240.0°F
		65.6°C	121.1°C	115.5°C

OPTIONS KEY

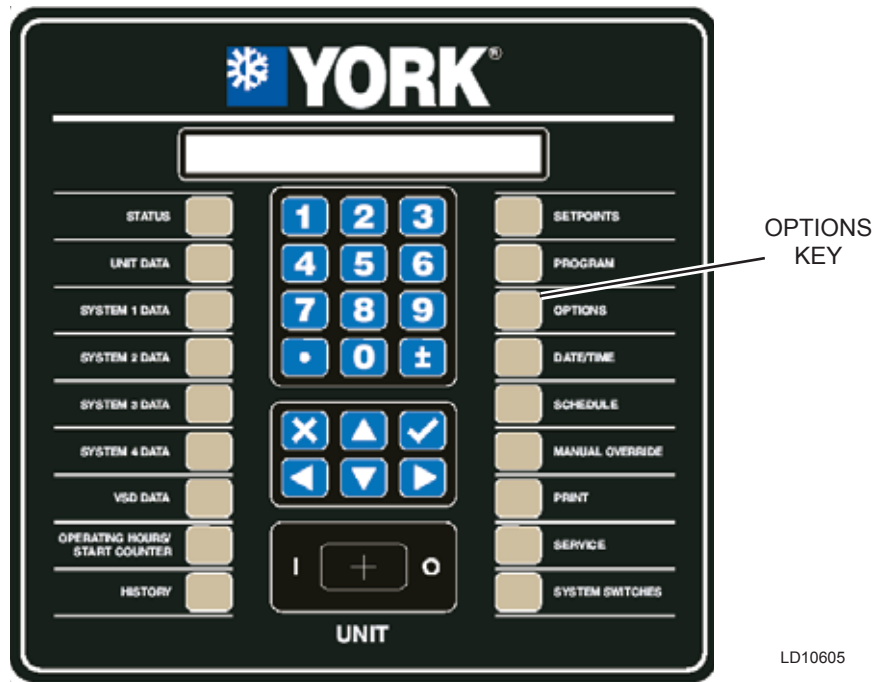

OPTIONS
KEY

LD10605

Options Key Operation

The OPTIONS key provides the user with a display of unit configuration and the capability to modify the configuration. These options can only be viewed under the OPTIONS key. To view the current options settings, press the OPTIONS key. Each press of the OPTIONS key or press of the ▲ or ▼ (ARROW) keys will scroll to the next option setting. The ◀ and ▶ (ARROW) keys allow changing the option choices. The ✓ (ENTER) key must be pressed after a selection is made to save the change in memory.

An explanation of each option message is provided below.

Display Language Selection

The display language can be selected for English, Italian, Polish, Hungarian, German, French, Portuguese, and Spanish.



The default language will be English.

Chilled Liquid Cooling Mode Selection

The Chilled liquid cooling mode can be selected for Water Cooling or low temperature Glycol Cooling.



When Water Cooling is chosen, the chilled liquid temperature setpoint can only be programmed from 4°C to 21°C (40°F to 70°F).



When Glycol Cooling is chosen, the chilled liquid temperature setpoint can be programmed from -12°C to 21°C (10°F to 70°F).



The default Chilled Liquid Mode will be WATER COOLING.

Local / Remote Control Mode Selection

Local or Remote Control Mode allows the user to select the chilled liquid temperature control mode.



When LOCAL CONTROL mode is selected, chilled liquid control is from the keypad of the chiller. In local mode, a remote device can read system data, but not reset operating parameters.

OPTIONS LOCAL / REMOTE CONTROL MODE
◀ ▶ **LOCAL CONTROL**

When REMOTE CONTROL mode is selected, control of the chilled liquid setpoint is from a remote device such as an ISN/BAS controller.

OPTIONS LOCAL / REMOTE CONTROL MODE
◀ ▶ **REMOTE CONTROL**

The default mode will be LOCAL CONTROL.

Display Units Selection

Imperial or SI display units may be selected for data display.

OPTIONS DISPLAY UNITS
◀ ▶ **XXXXXXXXXXXXXXXXXXXX**

The user may select system operating temperatures and pressures to be displayed in either SI (°C, barg) or Imperial units (°F, PSIG).

OPTIONS DISPLAY UNITS
◀ ▶ **IMPERIAL**

OPTIONS DISPLAY UNITS
◀ ▶ **SI**

The default mode is IMPERIAL.

System Lead/Lag Control Mode Selection

The operator may select the type of lead/lag control desired.

OPTIONS LEAD / LAG CONTROL MODE
◀ ▶ **XXXXXXXXXXXXXXXXXXXX**

In most cases, automatic lead/lag will be selected. When automatic lead/lag is selected, the microprocessor will attempt to balance run time by switching the lead compressor whenever all compressors are shut OFF. If a compressor is not able to run when the microprocessor attempts a start, the microprocessor will select another compressor in an effort to control chilled liquid temperature. Manual lead/lag allows selecting a specific compressor to be the lead.

OPTIONS LEAD / LAG CONTROL MODE
◀ ▶ **AUTOMATIC**

The default mode will be AUTOMATIC.

Lag selections of individual systems will appear as:

OPTIONS LEAD / LAG CONTROL MODE
◀ ▶ **MANUAL SYS 1 LEAD**

OPTIONS LEAD / LAG CONTROL MODE
◀ ▶ **MANUAL SYS 2 LEAD**

Remote Temperature Reset Selection

Remote temperature reset from an external source may be tied directly into the chiller microprocessor board.

OPTIONS REMOTE TEMP RESET INPUT
◀ ▶ **XXXXXXXXXXXXXXXXXXXX**

Selections may be made for DISABLED (no signal), 0 to 10VDC, 2 to 10VDC, 0 to 20ma, and 4 to 20ma.

OPTIONS REMOTE TEMP RESET INPUT
◀ ▶ **DISABLED**

OPTIONS REMOTE TEMP RESET INPUT
◀ ▶ **0.0 TO 10.0 VOLTS DC**

OPTIONS REMOTE TEMP RESET INPUT
◀ ▶ **2.0 TO 10.0 VOLTS DC**

OPTIONS REMOTE TEMP RESET INPUT
◀ ▶ **0.0 TO 20.0 MILLIAMPS**

OPTIONS REMOTE TEMP RESET INPUT
◀ ▶ **4.0 TO 20.0 MILLIAMPS**

The default setting for Remote Temp Reset is DISABLED. This display will only appear if the remote temperature limit option is enabled under the Unit Setup Mode.

Remote Current Limit Input Selection

Remote current limit from an external source may be tied directly into the chiller microprocessor board.

OPTIONS REMOTE CURRENT LIMIT INPUT
◀ ▶ **XXXXXXXXXXXXXXXXXXXX**

Selections may be made for DISABLED (no signal), 0 to 10VDC, 2 to 10VDC, 0 to 20ma, and 4 to 20ma.

OPTIONS REMOTE CURRENT LIMIT INPUT
 ◀ ▶ DISABLED

OPTIONS REMOTE CURRENT LIMIT INPUT
 ◀ ▶ 0.0 TO 10.0 VOLTS DC

OPTIONS REMOTE CURRENT LIMIT INPUT
 ◀ ▶ 2.0 TO 10 VOLTS DC

OPTIONS REMOTE CURRENT LIMIT INPUT
 ◀ ▶ 0.0 TO 20.0 MILLIAMPS

OPTIONS REMOTE CURRENT LIMIT INPUT
 ◀ ▶ 4.0 TO 20.0 MILLIAMPS

The default setting for Remote Current Reset is DISABLED. This display will only appear if the remote current limit option is enabled under the Unit Setup Mode.

Remote Sound Limit Selection

Remote sound limit from an external source may be tied directly into the chiller microprocessor board.

OPTIONS REMOTE SOUND LIMIT INPUT
 ◀ ▶ XXXXXXXXXXXXXXXXXXXXXXXX

Selections may be made for DISABLED (no signal), 0 to 10VDC, 2 to 10VDC, 0 to 20ma, and 4 to 20ma.

OPTIONS REMOTE SOUND LIMIT INPUT
 ◀ ▶ DISABLED

OPTIONS REMOTE SOUND LIMIT INPUT
 ◀ ▶ 0.0 TO 10.0 VOLTS DC

OPTIONS REMOTE SOUND LIMIT INPUT
 ◀ ▶ 2.0 TO 10.0 VOLTS DC

OPTIONS REMOTE SOUND LIMIT INPUT
 ◀ ▶ 0.0 TO 20.0 MILLIAMPS

OPTIONS REMOTE SOUND LIMIT INPUT
 ◀ ▶ 4.0 TO 20.0 MILLIAMPS

The default setting for Remote Sound Limit is DISABLED. This display will only appear if the remote sound limit option is enabled under the Unit Setup Mode.

Low Ambient Cutout Enable/Disable

The low ambient cutout may be enabled or disabled. When enabled, the chiller will cut OFF when the low ambient cutout is reached. When disabled, the chiller will run at any temperature.

OPTIONS LOW AMBIENT TEMPERATURE CUTOUT
 ◀ ▶ ENABLED

OPTIONS LOW AMBIENT TEMPERATURE CUTOUT
 ◀ ▶ DISABLED

The default setting for the low ambient cutout will be ENABLED.

DATE/TIME AND SCHEDULE KEYS

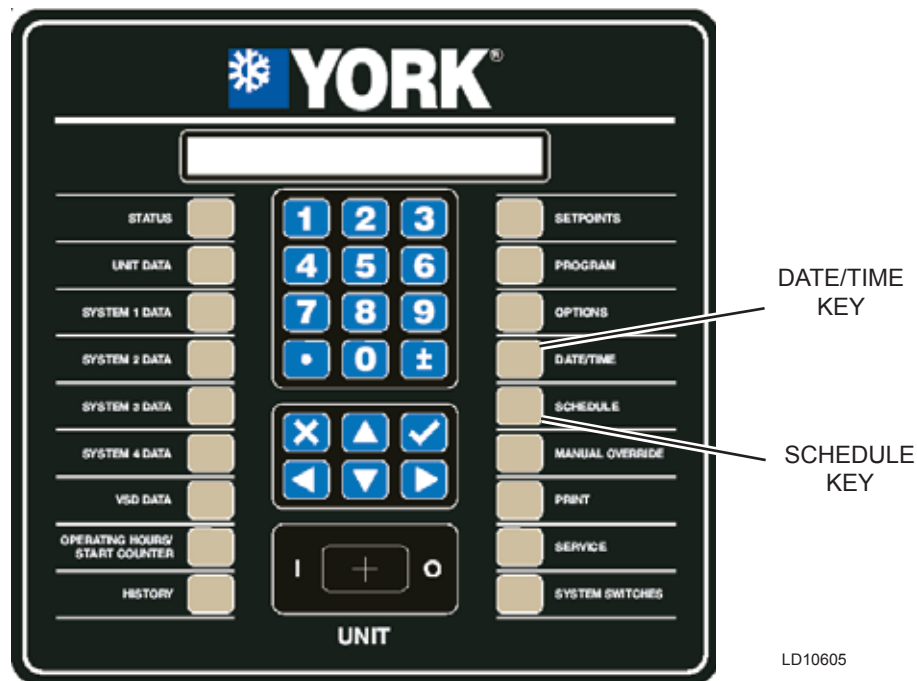

LD10605

Date/Time Key Operation

When the DATE/TIME key is pressed, the chiller microprocessor will display the date and the time. This feature is useful and required for using the Daily Schedule. It is also a valuable tool for troubleshooting to allow a technician to determine the time of the fault, which is stored in the history memory buffers. When the DATE/TIME key is pressed, the first display screen shown below will be displayed:

```
CLOCK FRI 18-JUN-2011 10:15:33 AM
DAY OF WEEK ◀ ▶ = XXX
```

Whenever any changes are made, the ✓ (ENTER) key must be pressed to store the data.

Pressing the ▲ or ▼ (Arrow) keys allows scrolling to the next programmed item. Pressing the ▼ (DOWN ARROW) key scrolls to the next item that can be programmed and the ▲ (UP ARROW) key scrolls to the previous item.

The day of the week is the first display and can be changed by pressing either the ◀ or ▶ (LEFT OR RIGHT ARROW) key to select the day. After the day is selected, the ✓ (ENTER) key must be pressed to store the data.

```
CLOCK FRI 18-JUN-2011 10:15:33 AM
DAY OF MONTH = XX
```

Pressing the ▼ (DOWN ARROW) key again scrolls to the day of the month:

```
CLOCK FRI 18-JUN-2011 10:15:33 AM
DAY OF MONTH = XX
```

The day of the month can be selected by keying in the numerical value to select the day. After the day of the month is selected, the ✓ (ENTER) key must be pressed to store the data.

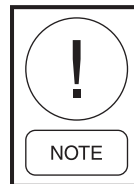

A "0" must be typed in to select dates for days of the 1st through the 9th.

Pressing the ▼ (DOWN ARROW) key again scrolls to month:

```
CLOCK FRI 18-JUN-2011 10:15:33 AM
MONTH ◀ ▶ = XXX
```

The month can be selected by scrolling through the months with the ◀ or ▶ arrow keys. After the month is selected, the ✓ (ENTER) key must be pressed to store the data.

Pressing the ▼ (DOWN ARROW) key again scrolls to the year:

CLOCK FRI 18-JUN-2011 10:15:33 AM
 YEAR = XXXX

The year can be selected by keying in the numerical value to select the year. After the year is selected, the ✓ (ENTER) key must be pressed to store the data.

Pressing the ▼ (DOWN ARROW) key again scrolls to the hour:

CLOCK FRI 18-JUN-2011 10:15:33 AM
 HOUR = XX

The hour can be selected by keying in the numerical value for the hour. After the hour is selected, the ✓ (ENTER) key must be pressed to store the data.

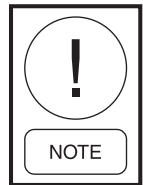

One or two "0's" must be keyed in for minutes 00 through 09.

Pressing the ▼ (DOWN ARROW) key again scrolls to the minute:

CLOCK FRI 18-JUN-2011 10:15:33 AM
 MINUTE = XX

The minute can be selected by keying in the numerical value for the hour. After the minute is selected, the ✓ (ENTER) key must be pressed to store the data.

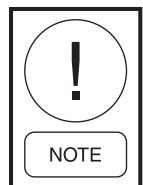

One or two "0's" must be keyed in for minutes 00 through 09.

Pressing the ▼ (DOWN ARROW) key again scrolls to AM/PM:

CLOCK FRI 18-JUN-2011 10:15:33 AM
 AM/PM ◀ ▶ = XX

AM/PM can be selected by pressing the ◀ or ▶ (ARROW) keys. After the meridian is selected, the ✓ (ENTER) key must be pressed to store the data.

Pressing the ▼ (DOWN ARROW) key again scrolls to the time format selection:

CLOCK FRI 18-JUN-2011 10:15:33 AM
 TIME FORMAT ◀ ▶ = XXXXXXXX

The time format may be displayed in either a 12 hour or 24 hour format. Selection can be changed by pressing the ◀ or ▶ (ARROW) keys. The ✓ (ENTER) key must be pressed to store the data.

Schedule Key Operation

The Daily Schedule must be programmed for the unit start and stop times. To set the schedule, press the SCHEDULE key. The display will provide a message allowing access to 2 types of schedule information:

SCHEDULE CHOOSE SCHEDULE TYPE
 ◀ ▶ XXXXXXXXXXXXXXXXXXXXXXXXXXXX

The schedule types are:

- UNIT OPERATING SCHEDULE
- (Default selection)
- SOUND LIMIT SCHEDULE
 (Only if Sound Limiting is enabled by the factory when the option is installed.)

The schedule type (UNIT OPERATING SCHEDULE or SOUND LIMIT SCHEDULE) may be changed by pressing the ◀ (LEFT ARROW) or ▶ (RIGHT ARROW) keys followed by the ✓ (ENTER) key. The selection must be entered by pressing the ✓ (ENTER) key before a schedule display will appear.

Unit Operating Schedule

The Unit Operating Schedule is used to enable/disable the chiller unit on time of day. The chiller can be enabled and disabled once each day or it can be programmed to run continuously. Any time the daily or holiday schedule shuts the chiller down, the running system(s) will go through a controlled ramped shut-down. If the UNIT OPERATING SCHEDULE is selected under the CHOOSE SCHEDULE display, the following message will appear:

SCHEDULE UNIT OPERATING
 MON START = 06:00 AM STOP = 10:00 PM

The line under the 0 above is the cursor. If the start time is wrong, it can be changed by keying in the new time from the numeric keypad. Once the correct values for the START hour and minute are entered, press the ✓ (ENTER) key. The cursor will then move to the AM/PM selection. The meridian (AM/PM) value may be changed by the ◀ (LEFT ARROW) or ▶ (RIGHT ARROW) keys and entered by pressing ✓ (ENTER) key. Repeat this process for the STOP time. Once a schedule is entered, the schedule for the next day will

appear. The start and stop time of each day may be programmed differently.

To view the schedule without making a change, simply press the SCHEDULE key until the day you wish to view appears. The ▲ (UP ARROW) key will scroll backwards to the previous screen.

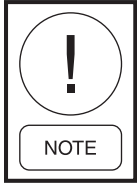

If at any time the schedule is changed for Monday, all the other days will change to the new Monday schedule. This means if the Monday times are not applicable for the whole week, then the exceptional days would need to be reprogrammed to the desired schedule.

To program the chiller for 24 hour operation, program the start and stop times of each day of the week for 00:00.

After the SUN (Sunday) schedule appears on the display, a subsequent press of the SCHEDULE or ▲ (UP ARROW) key will display the Holiday schedule. This is a two-part display. The first reads:

SCHEDULE	UNIT OPERATING
HOL	START = 00:00 AM STOP = 00:00 PM

The holiday times may be set using the same procedure as described above for the days of the week. Be sure to press the ✓ (ENTER) key after setting the START and STOP times to save the change in memory. Pressing the SCHEDULE key a second time, the display will show the individual days:

SCHEDULE	UNIT OPERATING
S M T W T F S	HOLIDAY NOTED BY *

The line below the empty space is the cursor and will move to the next or previous empty space when the ◀ (LEFT ARROW) or ▶ (RIGHT ARROW) keys are pressed. To set a day for the Holiday Schedule, the cursor must be moved to the space following the day of the week. The * key is then pressed and an “*” will appear in the space signifying that day as a holiday. The Holiday schedule must be programmed weekly. If there is no holiday, the “*” key is also used to delete the “*”. The ✓ (ENTER) key is used to accept the holiday schedule for the entire week.

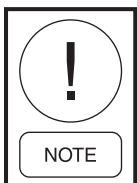

The HOLIDAY SCHEDULE is a temporary schedule. Once the schedule is executed, the selected holidays will be cleared from memory for the following week.

Sound Limit Schedule

The SOUND LIMIT SCHEDULE allows setting the day and time when the user desires using the “SILENT NIGHT” factory programmed option to limit chiller loading and fan operation for reduced audible noise in the surrounding area. If the SOUND LIMIT SCHEDULE is selected under the CHOOSE SCHEDULE display, the following message will appear:

SCHEDULE	SOUND LIMIT	= XXX %
MON	START = 06:00 AM	STOP = 10:00 PM

The Sound Limit option can be enabled and disabled once each day or the chiller can be set to run continuously in this mode for sound limiting whenever the chiller is operating. When sound limiting is enabled, the unit will be limited by the Sound Limit setpoint % as set under the PROGRAM key. XXX in the display above will show the Sound Limit Setpoint % programmed under the PROGRAM key. 0% will cause no speed reduction, while 100% only allows running at minimum speed.

The START Time for a specific day (hour and minute) is entered using the same guidelines used for the start/stop schedules, and press the ✓ (ENTER) key to store it into memory. The cursor will then move to the AM/PM selection.

The AM/PM selection may be chosen using the ◀ (LEFT ARROW) or ▶ (RIGHT ARROW) keys and pressing ✓ (ENTER) key to store the value.

This process is repeated for the STOP time.

Once the schedule for a specific day is programmed and entered, the schedule for the next day will appear. The schedule for each day may be programmed the same or differently.

To view the schedule without changing it, simply press the SCHEDULE key or the ▼ (DOWN ARROW) key until the desired day is displayed. The ▲ (UP ARROW) key will scroll backwards to the previous screen.

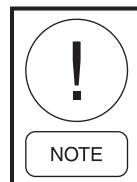

If the schedule is changed for Monday, all other days will change to the Monday schedule. Be aware of this when programming.

MANUAL OVERRIDE KEY

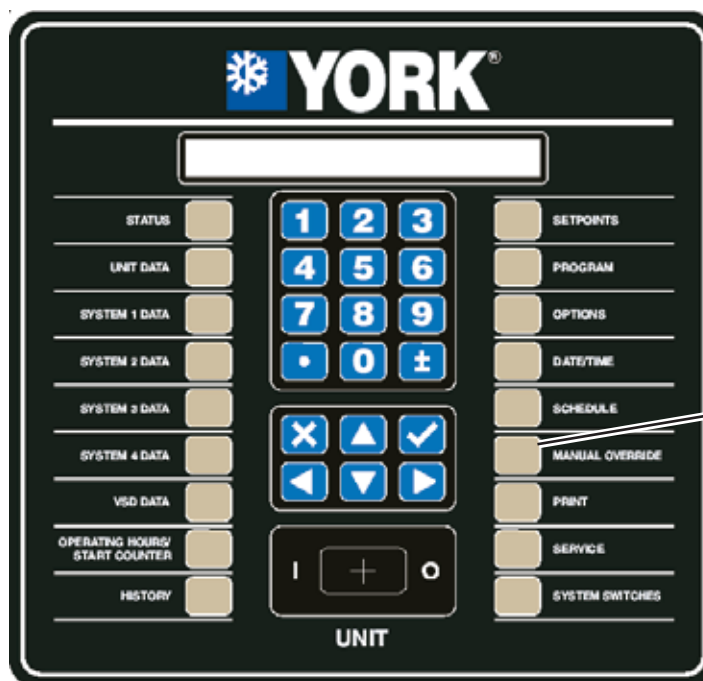

MANUAL OVERRIDE
KEY

LD10605

8

Manual Override Key Operation

If the MANUAL OVERRIDE key is pressed during a schedule shutdown, the STATUS display will display the message below. This indicates that the Daily Schedule is being ignored and the chiller will start when chilled liquid temperature allows, Remote Contacts, UNIT switch and SYSTEM switches permitting. This is a priority message and cannot be overridden by anti-recycle messages, fault messages, etc. when in

the STATUS display mode. Therefore, do not expect to see any other STATUS messages when in the MANUAL OVERRIDE mode. MANUAL OVERRIDE is to only be used in emergencies or for servicing. Manual override mode automatically disables itself after 30 minutes.

MANUAL OVERRIDE

PRINT KEY

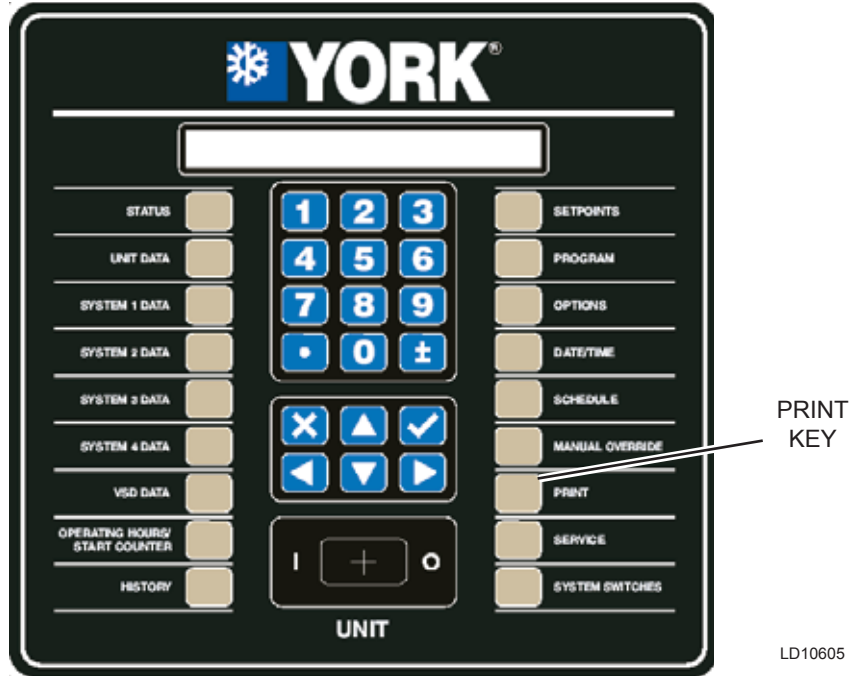

Print Key Operation

The PRINT key is used to initiate a printout of current operating data (real time data), a complete history printout of all history (fault) buffers, a printout of all normal shutdowns (compressor cycling, chiller shut-down, etc.) or history (fault) data printout of a specific fault. History Buffer 1 will always be the most recent fault history printout. Printing may also be canceled by selecting the CANCEL PRINTING option. The following message is displayed when the PRINT key is pressed.



After pressing the PRINT key, the printout type is selected by pressing the ◀ (LEFT ARROW) or ▶ (RIGHT ARROW) keys until the desired printout is displayed.

The following table shows the available printout types.

TABLE 13 - PRINTOUT TYPES

PRINTOUT TYPES
Operating Data (Default Selection)
All History Buffers
Normal Shutdowns
History Buffer 1
History Buffer 2
History Buffer 3
History Buffer 4
History Buffer 5
History Buffer 6
History Buffer 7
History Buffer 8
History Buffer 9
History Buffer 10
Cancel Printing

The specific printout is initiated by pressing the ✓ (ENTER) key.

A sample of the is shown below. The operating data printout is a snapshot of current system operating conditions when the printout was selected. The sample shows combined printouts of 2, 3, and 4 circuit units. The actual printout will only show data for the appropriate chiller type.

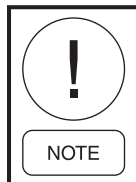

Bold italic text below a line of print is not on the actual printout. Bold italic text indicates information that may not be available on all printouts or is additional information to help explain the difference in a 2/3 or 4 circuit printout.

Operating Data Printout

```

YORK INTERNATIONAL CORPORATION
      YVAA SCREW CHILLER
      OPERATING DATA
      2:04:14 PM  30 DEC 11

SYS 1
NOT RUNNING
SYS 2
COMPRESSOR RUNNING

      OPTIONS

CHILLED LIQUID          WATER
LOCAL/REMOTE MODE      REMOTE
LEAD/LAG CONTROL        AUTOMATIC
REMOTE TEMP RESET       DISABLED
REMOTE CURRENT LIMIT     0 TO 10 V
REMOTE SOUND LIMIT       4 TO 20 MA
(if Sound Limiting enabled)
LOW AMBIENT CUTOUT      ENABLED

      PROGRAM VALUES

SUCTION PRESS CUTOUT    44 PSIG
LOW AMBIENT CUTOUT      25.0 DEGF
LEAVING LIQUID CUTOUT   36.0 DEGF
MOTOR CURRENT LIMIT     100 %FLA
PULLDOWN CURRENT LIMIT  100 %FLA
PULLDOWN LIMIT TIME     0 MIN
SUBCOOLING SETPOINT     12.0 DEGF
UNIT ID NUMBER          0
SOUND LIMIT SETPOINT    100%
(if Sound Limiting enabled)
    
```

```

UNIT DATA
LEAVING LIQUID TEMP      49.0 DEGF
RETURN LIQUID TEMP       58.2 DEGF
TEMP RATE                 XXX.X DEGF/MIN
COOLING RANGE            42.0+/-2.0 DEGF
REMOTE SETPOINT          44.0 DEGF
AMBIENT AIR TEMP         74.8 DEGF
LEAD SYSTEM              SYS 2
FLOW SWITCH              ON
EVAPORATOR PUMP RUN      ON
EVAPORATOR HEATER       OFF
ACTIVE REMOTE CONTROL    NONE
OPERATING HOURS 1=XXXXX, 2=XXXXX
START COUNTER 1=XXXXX,  2=XXXXX
SOFTWARE VERSION         C.ACS.XX.00

VSD DATA
ACTUAL FREQUENCY         XXX.X HZ
COMMAND FREQUENCY       XXX.X HZ
DC BUS VOLTAGE           XXX VDC
INTERNAL AMBIENT TEMP    XXX.X DEGF
COOLING SYSTEM STATUS    XXX
BASEPLATE TEMPS         XXX XXX DEGF
PRECHARGE SIGNAL        XXX
MOTOR OVERLOADS 1/2     XXX XXX AMPS
SOFTWARE VERSION         C.VSD.XX.00
UNIT SERIAL NUMBER       YYYY XXXZZZ

SYSTEM 1 DATA
COMPRESSOR STATUS       OFF
RUN TIME                0- 0- 0- 0 D-H-M-S
MOTOR CURRENT           0AMPS  0 %FLA
SUCTION PRESSURE        125 PSIG
DISCHARGE PRESSURE      131 PSIG
OIL PRESSURE            130 PSIG
CONDENSER LIQUID TEMP   68.4 DEGF
DISCHARGE TEMPERATURE   68.8 DEGF
OIL TEMPERATURE         68.8 DEGF
SAT SUCTION TEMP        71.8 DEGF
SUBCOOLING              3.4 DEGF
SAT DISCHARGE TEMP      74.5 DEGF
DISCHARGE SUPERHEAT     6.3 DEGF
MOTOR TMP               XXX.XXXX.XXXX.XDEGF
COMPRESSOR SPEED        XXX.X %
FLASH TANK LEVEL        > 512 ADC
    
```

```

COND DRAIN % OPEN          XXX.X %
ECONOMIZER % OPEN         XXX.X %
CONDENSER FANS ON          0
CONDENSER FAN SPEED        XXX % (vsd)
COMPRESSOR HEATER          ON
VI STEP SOLENOID 1         OFF
VI STEP SOLENOID 2         OFF
RUN PERMISSIVE             ON
VSD RUN RELAY              OFF
VSD SOFTWARE RUN SIGNAL    OFF

          SYSTEM 2 DATA
COMPRESSOR STATUS          ON
RUN TIME                   0-0-15-26 D-H-M-S
MOTOR CURRENT              104 AMPS  87 %FLA
SUCTION PRESSURE           57 PSIG
DISCHARGE PRESSURE         233 PSIG
OIL PRESSURE               218 PSIG
CONDENSER LIQUID TEMP      42.9 DEGF
DISCHARGE TEMPERATURE     145.5 DEGF
OIL TEMPERATURE           102.8 DEGF
SAT CONDENSER TEMP        31.7 DEGF
SUBCOOLING                 11.2 DEGF
SAT DISCHARGE TEMP        112.1 DEGF
DISCHARGE SUPERHEAT       33.4 DEGF
MOTOR TMP                  XXX.X XXX.X XXX.X DEGF
COMPRESSOR SPEED           XXX.X%
FLASH TANK LEVEL           < 512 ADC
COND DRAIN % OPEN          XXX.X%
ECONOMIZER % OPEN         XXX.X%
CONDENSER FANS ON          3
CONDENSER FAN SPEED        XXX% (vsd)
COMPRESSOR HEATER          OFF
VI STEP SOLENOID 1         OFF
VI STEP SOLENOID 2         OFF
RUN PERMISSIVE             ON
VSD RUN RELAY              OFF
VSD SOFTWARE RUN SIGNAL    OFF

          UNIT OPERATING SCHEDULE
S M T W T F S              *=HOLIDAY
MON START=00:00AM          STOP=00:00AM
TUE START=00:00AM          STOP=00:00AM
    
```

```

WED START=00:00AM          STOP=00:00AM
THU START=00:00AM          STOP=00:00AM
FRI START=00:00AM          STOP=00:00AM
SAT START=00:00AM          STOP=00:00AM
HOL START=00:00AM          STOP=00:00AM

          SOUND LIMIT SCHEDULE
          (if enabled)
MON START=00:00AM          STOP=00:00AM
TUE START=00:00AM          STOP=00:00AM
WED START=00:00AM          STOP=00:00AM
THU START=00:00AM          STOP=00:00AM
FRI START=00:00AM          STOP=00:00AM
SAT START=00:00AM          STOP=00:00AM
HOL START=00:00AM          STOP=00:00AM
    
```

History Data Printout

History printouts, when selected, provide stored data relating to all specific system and chiller operating conditions at the time of the fault, regardless of whether a lockout occurred. History information is stored in battery-backed memory on the Chiller Control Board and is not affected by power failures or resetting of faults. Whenever a fault of any type occurs, all system operating data is stored in battery-backed memory at the instant of the fault. The history printout is similar to the operating data printout except for the change in the header information shown below:

```

          YORK INTERNATIONAL CORPORATION
          YVAA SCREW CHILLER
          HISTORY NUMBER 1
          2:04:14 PM 30 APR 11
SYS 1 YYYYYYYY
          HIGH DSCH PRESS SHUTDOWN
          STATUS AT TIME OF SHUTDOWN
SYS 1 XXXXXXXXXXXXXXXXXXXXXXXXXXXXXXXX
SYS 2 XXXXXXXXXXXXXXXXXXXXXXXXXXXXXXXX
          ALL FAULTS
XXXXXXXXXXXXXXXXXXXXXXXXXXXXXXXXXXXXX
XXXXXXXXXXXXXXXXXXXXXXXXXXXXXXXXXXXXX
    
```

The most recent fault will always be stored as HISTORY BUFFER #1.

SYSTEM SWITCHES KEY

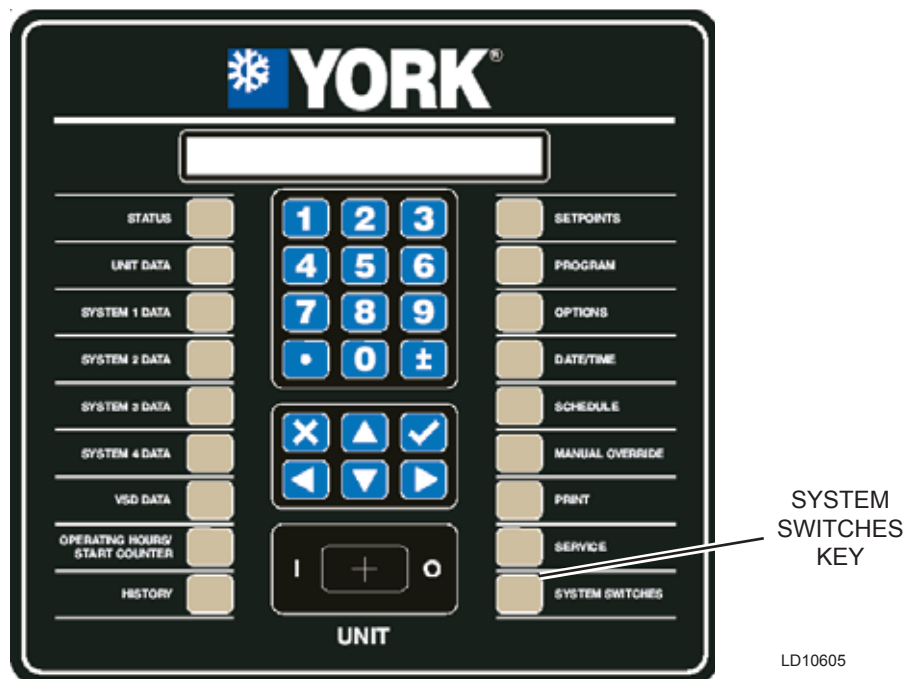

SYSTEM SWITCHES KEY

LD10605

System Switches Key Operation

The SYSTEM SWITCHES key allows the operator to turn individual systems ON and OFF. Safety lockouts are also reset by selecting the respective system switch RESET. When the SYSTEM SWITCHES key is pressed, the following message will appear:

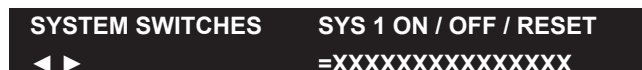

The display indicates the respective system and it's ON/OFF /reset switch status. The ▲▼ (ARROW) keys allow scrolling to the next and previous system switch (System 1 and 2).

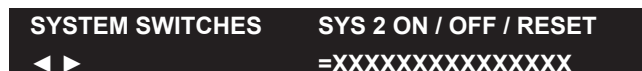

The ◀ (LEFT ARROW) or ▶ (RIGHT ARROW) keys allow scrolling through the choices of:

- SYSTEM OFF (default)
- SYSTEM ON
- RESET (LOCKOUT)

The switch selection is accepted into memory by pressing the ✓ (ENTER) key.

When the "RESET" selection is made and accepted, it will not change the position of the switch (either ON or OFF).

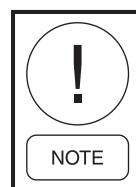

Whenever possible, except in emergencies, always use the associated system switch to turn off a compressor, which allows the compressors to go through a controlled shutdown. Avoid using the "UNIT" switch to turn off the compressors.

THIS PAGE INTENTIONALLY LEFT BLANK.

SECTION 9 - MAINTENANCE

GENERAL REQUIREMENTS

The units have been designed to operate continuously, provided they are regularly maintained and operated within the limitations given in this manual. Each unit should be included in a routine schedule of daily maintenance checks by the operator/customer, backed up by regular service inspection and maintenance visits by a suitably qualified Service Engineer.

It is entirely the responsibility of the owner to provide for these regular maintenance requirements and/or enter into a maintenance agreement with a Johnson Controls service organization to protect the operation of the unit. If damage or a system failure occurs due to improper maintenance during the warranty period, Johnson Controls shall not be liable for costs incurred to return the unit to satisfactory condition.

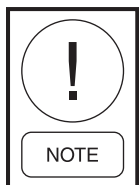

This “Maintenance” section applies to the basic unit only and may, on individual contracts, be supplemented by additional requirements to cover any modifications or ancillary equipment as applicable.



The “Safety” section of this manual should be read carefully before attempting any maintenance operations on the unit.

Weekly Maintenance

The following maintenance checks should be carried out on a weekly basis by the operator/customer. Please note that the units are not generally user serviceable and no attempt should be made to rectify faults or problems found during daily checks unless competent and equipped to do so. If in any doubt, contact your local Johnson Controls Service Agent.

Unit Status

Press the ‘STATUS’ key on the keypad and ensure no fault messages are displayed.

Refrigerant Leaks

Visually check the heat exchangers, compressors and pipework for damage and gas leaks.

Operating Conditions

Read the operating pressures and temperatures at the control panel using the display keys and check that these are within the operating limitations given in the manual.

Compressor Oil Level

Compressor oil level will typically run below the bottom of the sight glass. Oil levels will only be visible in the sight glass after running for periods of 15 to 30 minutes at full compressor speed. Do not run with oil levels above the sight glass. Be careful when viewing the sight glass not to confuse a full sight glass with an empty sight glass.

Refrigerant Charge

Assure there is a level of refrigerant in the evaporator sight glass while running at “Full Load” for 15 to 30 minutes.

Adding Charge to a System

A sight glass is located in the evaporator. When optimally charged after running full load, the refrigerant level should be approximately in the center of the sight glass. There should be little concern if the level is high or low in the glass, it should not affect operation.

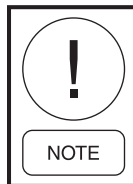

It is not necessary to weigh charge unless the entire charge has been lost. The ease of charging is possible since the micro-channel coils hold only a small amount of refrigerant charge. A charging valve, located between the fixed orifice and the evaporator, may be used if charge adjustment is required. Charge should be added as liquid while circulating water through the evaporator. If the complete charge needs to be added, see Refrigerant Removal, Evacuation and Charging a YVAA Chiller on Page 142 in this section. Use the valve on the liquid line for adding the full charge and open the valves per the procedure.

REFRIGERANT REMOVAL, EVACUATION AND CHARGING A YVAA CHILLER

Refrigerant Removal

The YVAA utilizes a flooded evaporator. Extreme care must be taken when removing refrigerant to prevent damage to the evaporator and the chiller. Carefully review the following caution below before proceeding with the recommended process.



Incorrect removal of refrigerant will result in catastrophic freeze damage to the evaporator and possible additional damage to other chiller components. Whenever there is water in the evaporator, the chilled liquid pumps must be ON and circulating liquid through the evaporator above minimum recommended flow rates. When liquid refrigerant is being removed, monitor the pressure and do not allow the pressure to drop below the freeze point of the chilled liquid flowing through the evaporator until all liquid refrigerant has been removed from the evaporator and only gas remains. Once all liquid has been removed, the remaining refrigerant vapor can be removed while allowing the pressure to drop below the freeze point with the pump circulating liquid through the evaporator.

To remove refrigerant from the evaporator, follow the procedure below:

1. Turn the chilled liquid pump ON and assure the flow is above the minimum recommended flow.
2. Assure all manual valves in the system are open. Open Condenser Drain and Economizer Feed valves to 100% in the service mode.
3. Connect the recovery unit and a manifold gauge to the liquid line feeding the eductor. There may be a valve in the line or a Schrader fitting on the eductor filter for this purpose.
4. Connect the recovery unit to a recovery cylinder sitting on an accurate scale. Turn the recovery unit ON and observe the liquid refrigerant flowing from the line into the cylinder. The flow of liquid should be obvious.

5. Monitor the pressure gauge to assure that the pressure does not drop below the freeze point of the chilled liquid. Throttle the flow as needed with the manifold gauge valves to prevent pressures from dropping below the freeze point.
6. Continue to remove the liquid refrigerant while observing the flow and the pressure. Note the charge in the system based on the nameplate data to determine when the charge removal is nearly complete. Monitor the weight of the recovery cylinder to determine when the cylinder is full. Change the cylinder as needed.
7. Continue removing refrigerant until liquid is no longer observed flowing in the manifold hoses.
8. Once the liquid is removed and no longer visible in the hose, the remaining gas can be pumped out with the recovery unit while the pressure is allowed to drop to 0 barg (0 PSIG).
9. Servicing may now be performed on the system as needed.

Evacuating a System

To evacuate a system, follow the procedure below:

1. Turn the chilled liquid pump ON and assure the flow is above the minimum recommended flow.
2. Assure all manual valves are open. Open the Condenser Drain (Flash Tank Feed) and Economizer Valves in the Service Mode to 100 %
3. Connect vacuum hoses to as many points as possible. Be sure that at least one connection is made on both the high and low side of the piping. A connection to the evacuation fitting on the compressor is also recommended. Evacuate the system to a minimum of 500 microns. Close the valves at the evacuation points and assure the pressure in the chiller does not rise more than 50 microns in 10 minutes. Check for leaks if the pressure rises.

Charging Refrigerant into a System

To charge the system with refrigerant, follow the procedure below:

1. With all system valves open and the Condenser Drain and Economizer Valves open to 100% by manually opening them in the Service Mode, charge refrigerant vapor into the high side of the system at the charging port on the liquid line. Continue charging vapor until the pressure is above the freeze point of the chilled liquid. Once above the freeze point, liquid can be charged according to the recommended nameplate charge.
2. Reconnect the water piping to the water boxes.
3. Close the evaporator drain valves and fill the evaporator with water from the cooling loop.
4. Fill the water loop and check for leaks.
5. Close (0%) the Condenser Drain and Economizer Valve in the Service Mode. Recycle the chiller power.
6. Once the system is operating, the charge will distribute itself throughout the system. Trim the charge as needed to a level of about midway on the evaporator sight glass while running full speed for 15 minutes.

MICROCHANNEL COIL CLEANING

The coil cleaning procedure for microchannel coils is significantly different than tube and fin type coils. As such, care must be taken to understand the differences to avoid damage to the microchannel coil. These differences require a number of DO NOT's that must be observed:

- DO NOT use coil cleaners or any chemical on a microchannel coil. This can cause severe damage to the coils.
- DO NOT use a pressure washer to clean the coils. While it is possible to clean a coil with a pressure washer, it's also possible to destroy it.
- DO NOT contact the coil with a hard surface such as a hose nozzle or metal vacuum nozzle or any other tool.

Microchannel coils tend to accumulate more dirt on the surface, but less dirt inside the coils, which makes them easier to clean. Follow the three steps below for cleaning the coils:

1. Remove surface debris such as dirt, leaves, insects, fibers, etc. with a vacuum cleaner having a soft attachment rather than a metal tube. Compressed air blown from the inside out can also be used. When brushing debris off the face of the coil a soft bristle (not wire) brush can be used. Do not scrape the coil with the vacuum nozzle, air nozzle, or any other tool.
2. Rinse the coil with tap water. Do not use coil cleaners. Rinse the coil from the inside out, running water through every passage in the heat exchanger surface until it is clean. Microchannel coils are stronger than conventional tube and fin coils, but handle them with care, since you can cause a leak due to impact. Use a gentle spray from a spray nozzle with a plastic end or put your finger on the end of the spray nozzle to reduce impact and provide a gentle spray.
3. Because of the fin geometry, microchannel coils retain water more than tube and fin style. It is generally recommended to blow or vacuum out the rinse water from the coils to speed drying and prevent water pooling.

Scheduled Maintenance

The maintenance operations detailed in the following table should be carried out on a regular basis by a suitably qualified Service Engineer. It should be noted that the interval necessary between each 'minor' and 'major' service can vary depending on, for instance, application, site conditions and expected operating schedule. Normally a 'minor' service should be carried out every three to six months and a 'major' service once a year. It is recommended that your local Johnson Controls Service Center is contacted for recommendations for individual sites.



MAINTENANCE REQUIREMENTS FOR YVAA CHILLERS

BY JOHNSON CONTROLS

PROCEDURE	WEEKLY	QUARTERLY	SEMI-ANNUALLY	ANNUALLY	EVERY 5 YEARS	EVERY * HOURS
Check Oil Level in Oil Separator Sight Glass.	X					
Check Liquid Line Sight Glass/ Moisture Indicator.	X					
Check refrigerant level in the Evaporator Sight Glass while running full load for 10 to 15 minutes.	X					
Record System Operating Temperatures & Pressures.	X					
Check Condenser Coils for dirt / debris and clean as necessary.	X					
Check Programmable Operating Setpoints and Safety Cutouts. Assure they are correct for the application.		X				
Check Compressor and Evaporator Heater operation.		X				
Check for dirt in the Panel. Check Door Gasket sealing integrity.		X				
**Leak check the Chiller.			X			
**Sample Compressor Oil, check for Acid, and replace if necessary.				X		
**Disconnect Power Source and Lock Out. Check tightness of Power Wiring connections.				X		
Check Glycol concentration on Low Temp. or other applications where freezing may be a problem.				X		
VSD Glycol Change.					X	

* Reserved for customer use for any special site requirements.

**This procedure must be performed at the specific time by an industry certified technician who has been trained and qualified to work on this type of equipment. A record of this procedure be successfully carried out should be maintained on file by the equipment owner should proof of adequate maintenance be required at a later date for warranty purposes.

TABLE 14 - TROUBLESHOOTING GUIDE

PROBLEM	POSSIBLE CAUSE	ACTION
NO DISPLAY ON CONTROL PANEL UNIT WILL NOT RUN.	Supply to the Panel is missing.	High Voltage to the Chiller is missing.
		Check 1FU, 2FU, 4FU, 5FU 17FU, or 19FU.
		Check 2T or 10T Transformer.
	Line Fuse is blown.	Check Fuses.
	Chiller Control Board is defective.	Replace Chiller Control Board.
	Display Board defective.	Replace Display Board.
LINE FUSE BLOWS.	SCR Diode Module is defective.	Check SCR/Diode Module.
	IGBT Module is defective.	Check IGBT Module.
	VSD Logic Board is defective.	Replace VSD Logic Board.
	SCR Trigger Board is defective.	Replace SCR Trigger Board.
CHILLER FAULT: LOW AMBIENT TEMPERATURE	Ambient temperature is lower than the programmed operating limit.	Check the programmed cutout and determine if it is programmed correctly.
	Ambient Sensor is defective.	Check the panel against the thermometer reading of ambient temperature.
CHILLER FAULT: HIGH AMBIENT TEMPERATURE	Ambient Temperature is above the maximum operating limit.	Check outside air temperature.
	Ambient Sensor is defective.	Check the Panel Display against Thermometer reading of Ambient Temperature at the sensor.
CHILLER FAULT: LOW LEAVING CHILLED LIQUID	Leaving chilled liquid temperature drops faster than the unit can unload.	Check for restricted flow.
		Check for rapid flow changes.
		Water loop is too small.
		Flow is below minimum for chiller.
	Chilled Water Sensor is defective.	Check Sensor against Temp. Gauge in water line.
		Check Sensor for intermittent operation.
Check Wiring for shorts or opens.		
SYSTEM FAULT: CONTROL VOLTAGE	System Fuse is blown.	Check respective system Fuse 20FU or 21FU.
SYSTEM FAULT: HIGH OIL TEMPERATURE	Oil Temperature Sensor is defective.	Check Sensor with infrared to determine if reading is reasonable.
	Condenser Fans NOT operating or running backwards.	Check Fans.
	Coils dirty.	Check and clean Coils.

NOTE: Always remove power to the chiller and assure the DC Bus voltage has bled off.

TABLE 14 - TROUBLESHOOTING GUIDE (CONT'D)

PROBLEM	POSSIBLE CAUSE	ACTION
SYSTEM FAULT: HIGH DISCHARGE PRESSURE	Coils dirty.	Check and clean coils.
	Coils are damaged.	Comb out fins.
	Fans NOT operating.	Check fan fuses.
		Check fan rotation.
		Check fan motor/blade.
System is overcharged.	Remove charge and check subcooling.	
SYSTEM FAULT: HIGH DISCHARGE TEMPERATURE	Discharge Temperature Sensor is defective.	Check Sensor.
	Condenser Fans NOT operating or are running backwards.	Check Fans.
	Coils dirty.	Check and clean Coils.
	High Superheat.	Measure Superheat with gauges and thermocouple. Determine cause.
SYSTEM FAULT: HIGH MOTOR TEMPERATURE	High Motor temperature input from one of the sensors.	Refrigerant charge low. Check subcooling.
		Excess charge in system, High discharge pressure. Check subcooling.
		High Superheat. Drain/Feed Valves NOT controlling. Isolate cause.
		Motor Sensor reading incorrectly. Program panel to ignore a single sensor.
		Economizer Solenoid energized at low speeds. Valve is leaking through.
SYSTEM FAULT: LOW SUCTION PRESSURE	Low charge.	Check subcooling.
	Transducer reads incorrectly.	Check transducer against a gauge.
	Suction Temp. Sensor reads incorrectly.	Check sensor against a thermocouple.
	Low flow.	Check flow.
	Condenser Drain (Flash Tank Feed) Valve NOT operating.	Check Feed and Drain Valve operation. Check superheat.
	Condenser or Drain (Flash Tank Feed) Valve defective.	Check Feed and Drain Valve operation. Check superheat.
SYSTEM FAULT: DISCHARGE PRESSURE LIMITING	Discharge Transducer is defective.	Check transducer against a gauge.
	Ambient Temp. very high.	Normal operation.
	Fans NOT operating.	Check fan operation.
	Remote or local discharge pressure load limiting is programmed.	Normal operation.

NOTE: Always remove power to the chiller and assure the DC Bus voltage has bled off.

TABLE 14 - TROUBLESHOOTING GUIDE (CONT'D)

PROBLEM	POSSIBLE CAUSE	ACTION
SYSTEM STATUS: MOTOR CURRENT LIMITING	A high motor current anticipatory control has activated current limiting	Ambient temperature is high, normal response from controller
		Remote or panel limiting is in effect, Normal response.
		Excess charge in system, adjust charge.
		Condenser coils dirty, Clean condenser.
		Fans NOT operating. Check fans.
VSD FAULT: HIGH BASEPLATE TEMPERATURE	Coolant level low.	Add coolant.
	Glycol Pump is defective.	Replace Glycol Pump.
	VSD Board is defective	Replace VSD Logic Board.
	IGBT Module is defective.	Check defective IGBT Module.
VSD FAULT: LOW DC BUS VOLTAGE	SCR / Diode Module is defective.	Check SCR / Diode Module.
	SCR Trigger Board is defective.	Check SCR Trigger Board.

NOTE: Always remove power to the chiller and assure the DC Bus voltage has bled off.

CHILLED LIQUID AND SUCTION TEMPERATURE SENSOR INPUT VOLTAGE**TABLE 15 - TEMPERATURE INPUT VOLTAGE SENSOR (MEASURED SIGNAL TO SHIELD AT THE SENSOR)**

TEMP. °F (°C)	VOLTAGE	TEMP. °F (°C)	VOLTAGE	TEMP. °F (°C)	VOLTAGE
16.1 (-8.8)	1.52	35.9 (2.2)	2.19	55.6 (13.1)	2.85
16.7 (-8.5)	1.54	36.5 (2.5)	2.21	56.3 (13.5)	2.87
17.3 (-8.2)	1.56	37.0 (2.8)	2.23	56.9 (13.8)	2.89
17.9 (-7.8)	1.58	37.6 (3.1)	2.25	57.5 (14.2)	2.91
18.5 (-7.5)	1.60	38.2 (3.4)	2.27	58.1 (14.5)	2.93
19.1 (-7.2)	1.62	38.7 (3.7)	2.29	58.7 (14.8)	2.95
19.7 (-6.8)	1.64	39.3 (4.1)	2.30	59.4 (15.2)	2.97
20.3 (-6.5)	1.66	39.9 (4.4)	2.32	60.0 (15.6)	2.99
20.9 (-6.2)	1.68	40.4 (4.7)	2.34	60.6 (15.9)	3.01
21.5 (-5.8)	1.70	41.0 (5.0)	2.36	61.3 (16.3)	3.03
22.1 (-5.5)	1.72	41.6 (5.3)	2.38	61.9 (16.6)	3.05
22.7 (-5.2)	1.74	42.1 (5.6)	2.40	62.5 (16.9)	3.07
23.3 (-4.8)	1.76	42.7 (5.9)	2.42	63.2 (17.3)	3.09
23.9 (-4.5)	1.78	43.3 (6.3)	2.44	63.8 (17.7)	3.11
24.5 (-4.2)	1.80	43.9 (6.6)	2.46	64.5 (18.1)	3.13
25.0 (-3.9)	1.82	44.4 (6.9)	2.48	65.1 (18.4)	3.14
25.6 (-3.6)	1.84	45.0 (7.2)	2.50	65.8 (18.8)	3.16
26.2 (-3.2)	1.86	45.6 (7.5)	2.52	66.5 (19.2)	3.18
26.8 (-2.9)	1.88	46.2 (7.9)	2.54	67.1 (19.5)	3.20
27.3 (-2.6)	1.90	46.7 (8.2)	2.56	67.8 (19.9)	3.22
27.9 (-2.8)	1.91	47.3 (8.5)	2.58	68.5 (20.3)	3.24
28.5 (-1.9)	1.93	47.9 (8.8)	2.60	69.2 (20.7)	3.26
29.0 (-1.7)	1.95	48.5 (9.2)	2.62	69.9 (21.1)	3.28
29.6 (-1.3)	1.97	49.1 (9.5)	2.64	70.6 (21.4)	3.30
30.2 (-1)	1.99	49.7 (9.8)	2.66	71.3 (21.8)	3.32
30.8 (-0.7)	2.01	50.3 (10.2)	2.68	72.0 (22.2)	3.34
31.3 (-0.4)	2.03	50.8 (10.4)	2.70	72.7 (22.6)	3.36
31.9 (-0.1)	2.05	51.4 (10.8)	2.71	73.4 (23)	3.38
32.5 (0.3)	2.07	52.0 (11.1)	2.73	74.2 (23.4)	3.40
33.0 (0.6)	2.09	52.6 (11.4)	2.75	74.9 (23.8)	3.42
33.6 (0.9)	2.11	53.2 (11.8)	2.77		
34.2 (1.2)	2.13	53.8 (12.1)	2.79		
34.8 (1.5)	2.15	54.5 (12.5)	2.81		
35.3 (1.8)	2.17	55.0 (12.8)	2.83		

**TABLE 16 - OUTSIDE AIR TEMPERATURE SENSOR INPUT VOLTAGE
 (MEASURED SIGNAL TO SHIELD AT THE SENSOR)**

TEMP. °F (°C)	VOLTAGE	TEMP. °F (°C)	VOLTAGE	TEMP. °F (°C)	VOLTAGE
0.24 (-17.6)	0.68	49.8 (9.9)	2.00	93.3 (34.1)	3.31
1.79 (-16.8)	0.71	50.7 (10.4)	2.03	94.4 (34.7)	3.34
3.30 (-15.9)	0.74	51.6 (10.9)	2.06	95.6 (35.3)	3.37
4.76 (-15.1)	0.77	52.5 (11.4)	2.09	96.8 (36)	3.40
6.19 (-14.3)	0.80	53.4 (11.9)	2.11	98.0 (36.7)	3.43
7.58 (-13.6)	0.83	54.3 (12.4)	2.14	99.2 (37.3)	3.46
8.94 (-12.8)	0.85	55.3 (12.9)	2.17	100.4 (38)	3.49
10.3 (-12.1)	0.88	56.2 (13.4)	2.20	101.6 (38.7)	3.52
11.6 (-11.3)	0.91	57.1 (13.9)	2.23	102.9 (39.4)	3.55
12.8 (-10.7)	0.94	58.0 (14.4)	2.26	104.2 (40.1)	3.57
14.1 (-9.9)	0.97	58.9 (14.9)	2.29	105.5 (40.8)	3.60
15.3 (-9.3)	1.00	59.8 (15.4)	2.32	106.8 (41.6)	3.63
16.5 (-8.6)	1.03	60.7 (15.9)	2.35	108.1 (42.3)	3.66
17.7 (-7.9)	1.06	61.6 (16.4)	2.38	109.5 (43.1)	3.69
18.9 (-7.3)	1.09	62.6 (17)	2.41	110.9 (43.8)	3.72
20.0 (-6.7)	1.12	63.5 (17.5)	2.44	112.3 (44.6)	3.75
21.2 (-6)	1.15	64.4 (18)	2.47	113.8 (45.4)	3.78
22.3 (-5.4)	1.18	65.3 (18.5)	2.50	115.2 (46.2)	3.81
23.4 (-4.8)	1.21	66.3 (19.1)	2.52	116.7 (47.1)	3.84
24.4 (-4.2)	1.24	67.2 (19.5)	2.55	118.3 (47.9)	3.87
25.5 (-3.6)	1.26	68.1 (20.1)	2.58	119.9 (48.8)	3.90
26.6 (-3)	1.26	69.1 (20.6)	2.61	121.5 (49.7)	3.93
27.6 (-2.4)	1.32	70.0 (21.1)	2.64	123.2 (50.7)	3.96
28.7 (-1.8)	1.35	70.9 (21.6)	2.67	124.9 (51.6)	3.98
29.7 (-1.3)	1.38	71.9 (22.2)	2.70	126.6 (52.6)	4.01
30.7 (-0.7)	1.41	72.8 (22.7)	2.73	128.4 (53.6)	4.04
31.7 (-0.2)	1.44	73.8 (23.2)	2.76	130.3 (54.6)	4.07
32.7 (0.4)	1.47	74.8 (23.8)	2.76		
33.7 (0.9)	1.50	75.8 (24.3)	2.82		
34.7 (1.5)	1.53	76.7 (24.8)	2.85		
35.7 (2.1)	1.56	77.7 (25.4)	2.88		
36.7 (2.6)	1.59	78.7 (25.9)	2.91		
37.6 (3.1)	1.62	79.7 (26.5)	2.93		
38.6 (3.7)	1.65	80.7 (27.1)	2.96		
39.6 (4.2)	1.67	81.7 (27.6)	2.99		
40.5 (4.7)	1.70	82.7 (28.2)	3.02		
41.4 (5.2)	1.73	83.6 (28.7)	3.05		
42.4 (5.8)	1.76	84.6 (29.2)	3.08		
43.3 (6.3)	1.79	85.7 (29.8)	3.11		
44.3 (6.8)	1.82	86.7 (30.4)	3.13		
45.2 (7.3)	1.85	87.8 (31)	3.16		
46.1 (7.8)	1.88	88.9 (31.6)	3.19		
47.0 (8.3)	1.91	90.1 (32.3)	3.22		
48.0 (8.9)	1.94	91.1 (32.8)	3.25		
48.9 (9.4)	1.97	92.2 (33.4)	3.28		

TABLE 17 - PRESSURE TRANSDUCER OUTPUT VOLTAGE
(MEASURED SIGNAL TO RETURN AT THE TRANSDUCER)

SUCTION PRESSURE TRANSDUCER (125 PSIG)		DISCHARGE CONDENSER LIQUID PRESSURE AND DISCHARGE PRESSURE TRANSDUCER (400 PSIG)	
PRESSURE	VOLTAGE	PRESSURE	VOLTAGE
0	0.50	0	0.50
5	0.66	25	0.75
10	0.82	50	1.00
15	0.98	75	1.25
20	1.14	100	1.50
25	1.30	125	1.75
30	1.46	150	2.00
35	1.62	175	2.25
40	1.78	200	2.50
45	1.94	225	2.75
50	2.10	250	3.00
55	2.26	275	3.25
60	2.42	300	3.50
65	2.58	325	3.75
70	2.74	350	4.00
75	2.90	375	4.25
80	3.06	400	4.50
85	3.22		
90	3.38		
95	3.54		
100	3.70		
105	3.86		
110	4.02		
115	4.18		
120	4.34		
125	4.50		

**TABLE 18 - MOTOR TEMPERATURE SENSOR RESISTANCE
 (CHECK AT THE MOTOR)**

TEMP. °F (°C)	R NOMINAL (OHMS)	R TOL (± %)	RMIN (OHMS)	RMAX (OHMS)
-4 (-20)	97,062	5.00	92,209	101,915
5 (-15)	77,941	4.60	69,586	76,296
14 (-10)	55,391	4.20	52,996	57,643
23 (-5)	42,324	3.85	40,695	43,954
32 (0)	32,654	3.50	31,511	33,797
41 (5)	25,396	3.15	24,596	26,196
50 (10)	19,903	2.80	19,346	20,461
59 (15)	15,713	2.50	15,321	16,106
68 (20)	12,493	2.20	12,218	12,768
77 (25)	10,000	2.00	9,800	10,200
86 (30)	8,056	2.40	7,863	8,250
95 (35)	6,531	2.70	6,354	6,707
104 (40)	5,326	3.00	5,166	5,485
113 (45)	4,368	3.25	4,226	4,510
122 (50)	3,602	3.50	3,476	3,728
131 (55)	2,986	3.75	2,874	3,098
140 (60)	2,488	4.00	2,389	2,588
149 (65)	2,083	4.25	1,995	2,172
158 (70)	1,753	4.50	1,674	1,832
167 (75)	1,481	4.75	1,411	1,551
176 (80)	1,257	5.00	1,194	1,321
185 (85)	1,071	5.20	1,016	1,127
194 (90)	916.9	5.40	867.4	966.4
203 (95)	787.7	5.60	743.6	831.9
212 (100)	679.3	5.80	639.9	718.7
221 (105)	587.9	6.00	552.6	623.2
230 (110)	510.6	6.20	479.9	542.3
239 (115)	445.0	6.40	416.5	473.5
248 (120)	389.0	6.60	363.4	414.7
257 (125)	341.2	6.70	318.4	364.1
266 (130)	300.2	6.90	279.5	320.9
275 (135)	264.9	7.10	246.1	283.7
284 (140)	234.4	7.30	217.3	251.5
293 (145)	208.0	7.40	192.6	223.3
302 (150)	185.0	7.50	171.1	198.9

THIS PAGE INTENTIONALLY LEFT BLANK.

SECTION 10 - DECOMMISSIONING, DISMANTLING AND DISPOSAL



Never release refrigerant to the atmosphere when emptying the refrigerating circuits. Suitable retrieval equipment must be used. If reclaimed refrigerant cannot be reused. It must be returned to the manufacturer.



Never discard used compressor oil, as it contains refrigerant in solution. Return used oil to the oil manufacturer.

Never discard used compressor oil, as it contains refrigerant in solution. Return used oil to the oil manufacturer.

Unless otherwise indicated, the operations described below can be performed by any properly trained maintenance technician.

GENERAL

Isolate all sources of electrical supply to the unit including any control system supplies switched by the unit. Ensure that all points of isolation are secured in the 'OFF' position. The supply cables may then be disconnected and removed. For connection points refer to *SECTION 4 - INSTALLATION*.

Remove all refrigerant from each system of the unit into a suitable container using a refrigerant reclaim or recovery unit. This refrigerant may then be re-used, if appropriate, or returned to the manufacturer for disposal. Under NO circumstances should refrigerant be vented to atmosphere. Drain the refrigerant oil from each system into a suitable container and dispose of according to local laws and regulations governing the disposal of oily wastes. Any spilt oil should be mopped up and similarly disposed of.

Isolate the unit heat exchanger from the external water systems and drain the heat exchanger section of the system. If no isolation valves are installed it may be necessary to drain the complete system.



If glycol or similar solutions have been used in the water system, or chemical additives are contained, the solution MUST be disposed of in a suitable and safe manner. Under NO circumstances should any system containing glycol or similar solutions be drained directly into domestic waste or natural water systems.

After draining, the water pipework can be disconnected and removed.

Packaged units can generally be removed in one piece after disconnection as above. Any fixing down bolts should be removed and then the unit should be lifted from position using the points provided and equipment of adequate lifting capacity.

Reference should be made to *SECTION 4 - INSTALLATION* for unit installation instructions, *SECTION 9 - MAINTENANCE* for unit weights and *SECTION 3 - RIGGING, HANDLING AND STORAGE* for handling.

Units which cannot be removed in one piece after disconnection as above must be dismantled in position. Special care should be taken regarding the weight and handling of each component. Where possible units should be dismantled in the reverse order of installation.



Residual refrigerant oil and glycol or similar solutions may remain in some parts of the system. These should be mopped up and disposed of as described above.

It is important to ensure that whilst components are being removed the remaining parts are supported in a safe manner.



Only use lifting equipment of adequate capacity.

After removal from position the unit parts may be disposed of according to local laws and regulations.

NOTES

The following factors can be used to convert from English to the most common SI Metric values.

TABLE 19 - SI METRIC CONVERSION

MEASUREMENT	MULTIPLY ENGLISH UNIT	BY FACTOR	TO OBTAIN METRIC UNIT
Capacity	Tons Refrigerant Effect (ton)	3.516	Kilowatts (kW)
Power	Horsepower	0.7457	Kilowatts (kW)
Flow Rate	Gallons / Minute (gpm)	0.0631	Liters / Second (l/s)
Length	Feet (ft)	0.3048	Meters (m)
	Inches (in)	25.4	Millimeters (mm)
Weight	Pounds (lbs)	0.4538	Kilograms (kg)
Velocity	Feet / Second (fps)	0.3048	Meters / Second (m/s)
Pressure Drop	Feet of Water (ft)	2.989	Kilopascals (kPa)
	Pounds / Square Inch (psi)	6.895	Kilopascals (kPa)

TEMPERATURE

To convert degrees Fahrenheit (°F) to degrees Celsius (°C), subtract 32° and multiply by 5/9 or 0.5556.

Example: $(45.0^{\circ}\text{F} - 32^{\circ}) \times 0.5556 = 27.2^{\circ}\text{C}$

To convert a temperature range (i.e., a range of 10°F) from Fahrenheit to Celsius, multiply by 5/9 or 0.5556.

Example: $10.0^{\circ}\text{F range} \times 0.5556 = 5.6^{\circ}\text{C range}$



P.O. Box 1592, York, Pennsylvania USA 17405-1592
Copyright © by Johnson Controls 2015
Form 201.28-NM1.1 (215)
Issue Date: February 6, 2015
Supersedes 201.28-NM1.1 (514)

800-861-1001
www.johnsoncontrols.com

Subject to change without notice. Printed in USA
ALL RIGHTS RESERVED